

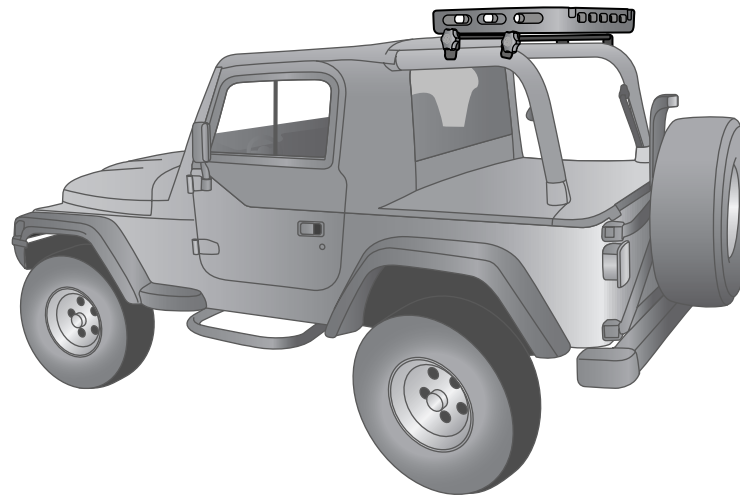

Upper Cargo Rack Bracket Installation Instructions

For: Wrangler, 1997 - 2002

Part Number: 41408



	WARNING
<p>This product is designed to enhance the appearance of the vehicle. Do not rely in any way on the components of this product to contain occupants within the vehicle, or to protect against injury or death in the event of an accident. Never operate vehicle in excess of manufacturer's specifications.</p>	
WEAR SEAT BELTS AT ALL TIMES	
<p>Read and follow, precisely, all installation instructions provided when installing this product. Failure to do so could place occupants of the vehicle in a potentially dangerous situation. After installing or reinstalling, check to make sure it has been properly installed.</p>	

Table of Contents	
UPPER CARGO RACK BRACKET PARTS LIST	PAGE 2
UPPER CARGO RACK BRACKET HARDWARE IDENTIFICATION	PAGE 2
UPPER CARGO RACK BRACKET TOOLS NEEDED	PAGE 2
UPPER CARGO RACK BRACKET INSTALLATION	PAGE 2
UPPER CARGO RACK BRACKET WARRANTY	PAGE 4

Parts List and Hardware Identification

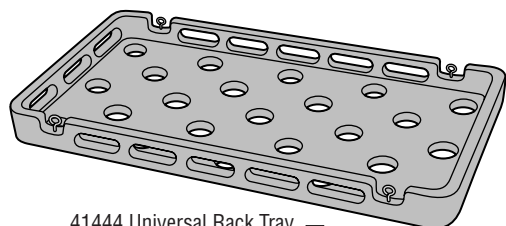

41444 Universal Rack Tray
(Sold Separately), Qty - 1

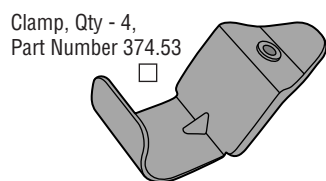

Clamp, Qty - 4,
Part Number 374.53

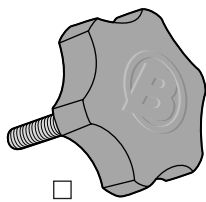

Knob, Qty - 4,
Part Number 374.54

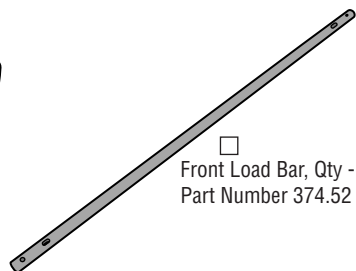

Front Load Bar, Qty - 1,
Part Number 374.52



Spacer, Qty - 2,
Part Number 374.57

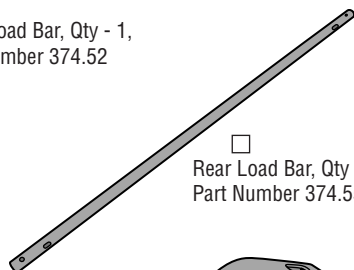

Rear Load Bar, Qty - 1,
Part Number 374.55

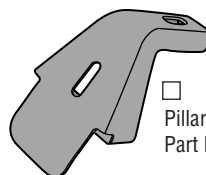

Pillar, Qty - 4,
Part Number 374.50

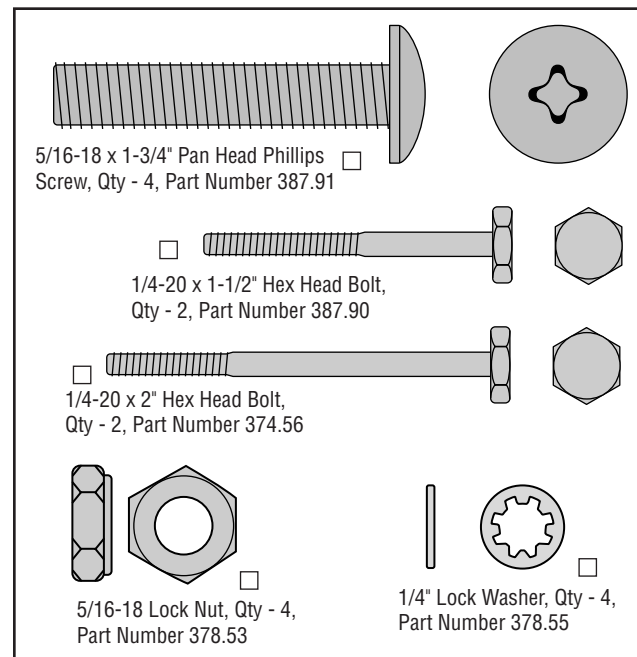

Tools Needed

#2 Phillips Screwdriver
7/16" Wrench
1/2" Wrench

Installation



Caution

DO NOT overtighten the bolts that attach the Pillars to the Tray. This may strip the aluminum inserts in the Tray.

Step One

INSTALL PILLARS ON LOAD BARS

Locate the Pillars and Load Bars in the parts kit. Use a 5/16-18 x 1-1/2" Hex Bolt and a 5/16-18 Lock Nut to install a Pillar on the end of each Load Bar.

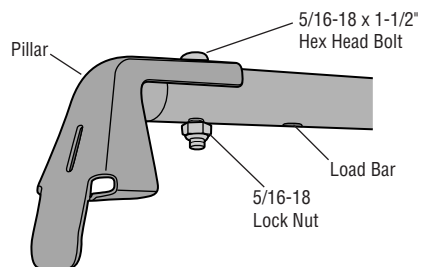

Step Two

INSTALL FRONT LOAD BAR ON TRAY ASSEMBLY

The Front Load Bar is the one which has the slots in line with the holes for the Pillars. Turn the Tray over and place the Front Load Bar Assembly on the bottom of the Tray with the Pillars perpendicular to the Tray. Fasten the Pillars directly to the bottom of the Tray with two 1/4-20 x 1-1/2" Hex Bolts and two 1/4" Lock Washers.

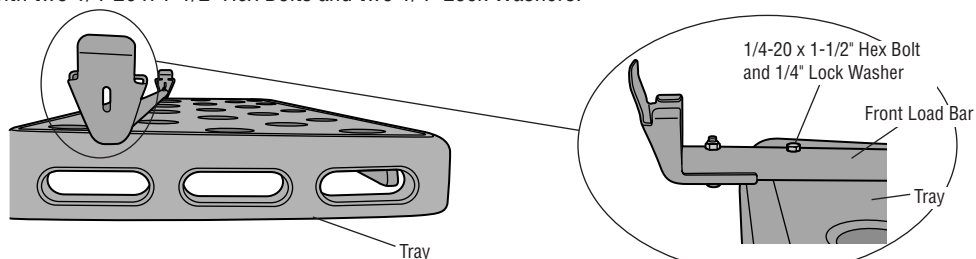

Note: Hold the Lock Washers while tightening the bolts so that they don't fall into the slot.



Caution

DO NOT overtighten the bolts that attach the Pillars to the Tray. This may strip the aluminum inserts in the Tray.

Step Three

INSTALL REAR LOAD BAR ON TRAY ASSEMBLY

The Rear Load Bar is the one which has the slots at a different angle than the holes for the Pillars. Orient the Rear Load Bar Assembly on the bottom of the Tray so that the Pillars angle toward the Front Pillars. Place a Spacer over each mounting hole between the Tray and the Rear Load Bar and secure the Load Bar with two 1/4-20 x 2" Hex Bolts and two 1/4" Lock Washers.

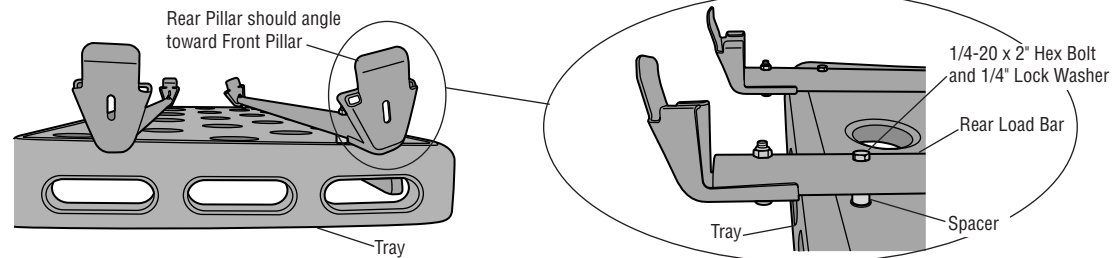

Note: Hold the Lock Washers while tightening the bolts so that they don't fall into the slot.

Step Four

PLACE TRAY ASSEMBLY ON VEHICLE

Place the Tray Assembly on top of the rear sport bar. Make sure that it is level. If you have an Original Equipment sound bar, the Front Pillar will sit right next to it.

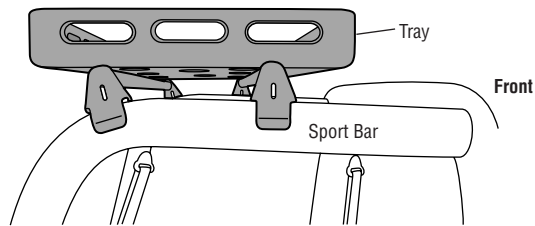

Step Five

INSTALL CLAMPS

Use a Knob and Clamp to secure each Pillar to the sport bar. Place a clamp around the sport bar behind the slot in the Pillar. Push the Clamp and Pillar together, insert the Knob shaft into the slot in the Pillar and thread it into the Clamp.

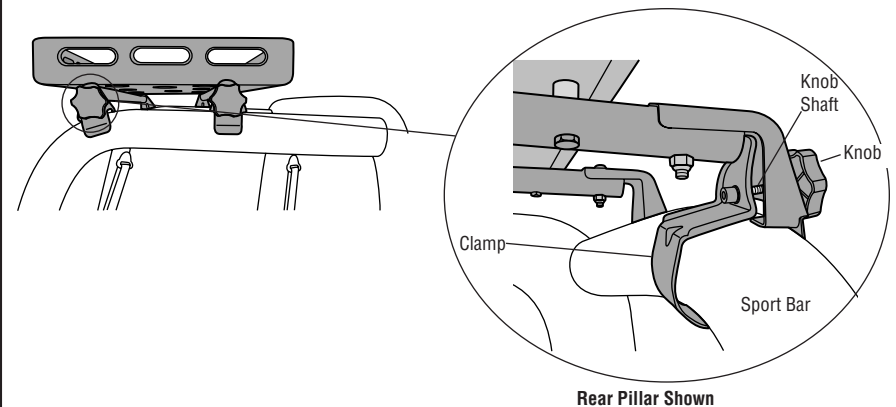

Step Six

Tighten Fasteners

Fully tighten the screws that attach the Load Bar to the Pillars. Make sure that the Knobs are tight before using the Tray.



Caution

DO NOT load the Tray with more than 100 evenly distributed pounds.

LIMITED WARRANTY

We warrant our product to be free from defects in material and workmanship, for terms specified below, provided there has been normal use and proper maintenance. This warranty applies to the original purchaser only. All remedies under this warranty are limited to the repair or replacement of any item or items found by the factory to be defective within the time period specified.

If you have a warranty claim, first you must call our factory at the number below for instructions. You must retain proof of purchase and submit a copy with any items returned for warranty work. Upon completion of warranty work, if any, we will return the repaired or replaced item or items to you freight prepaid. Damage to our products caused by accidents, fire, vandalism, negligence, misinstallation, misuse, Acts of God, or by defective parts not manufactured by us, is not covered under this warranty.

THE WARRANTY TIME PERIOD IS AS FOLLOWS: ALL "GOODS" MANUFACTURED BY OUR COMPANY: ONE YEAR FROM DATE OF PURCHASE.

ANY IMPLIED WARRANTIES OF MERCHANTABILITY AND/OR FITNESS FOR A PARTICULAR PURPOSE CREATED HEREBY ARE LIMITED IN DURATION TO THE SAME DURATION AND SCOPE AS THE EXPRESS WRITTEN WARRANTY. OUR COMPANY SHALL NOT BE LIABLE FOR ANY INCIDENTAL OR CONSEQUENTIAL DAMAGE.

Some states do not allow limitations on how long an implied warranty lasts, or the exclusion or limitation of incidental or consequential damages, so the above limitations or exclusions may not apply to you.

This warranty gives you specific legal rights, and you may also have other rights which vary from state to state.

For further information, please contact:

Bestop Inc.
Customer Service
(800)845-3567
(303)465-1755

