



INSTATRUNK™ Installation Instructions



For: Jeep Wranglers 1997+

Part Number: 42632

Jeep® is a registered trademark of Chrysler and Bestop is not affiliated with Chrysler Corporation.

	WARNING
<p>This product is designed to enhance the appearance of the vehicle and to shield the occupants from ordinary weather conditions. Do not rely in any way on the components of this product to contain occupants within the vehicle, or to protect against injury or death in the event of an accident. Never operate vehicle in excess of manufacturer's specifications.</p>	
WEAR SEAT BELTS AT ALL TIMES	
<p>Read and follow, precisely, all installation instructions provided when installing this product. Failure to do so could place occupants of the vehicle in a potentially dangerous situation. After installing or reinstalling, check to make sure it has been properly installed.</p>	

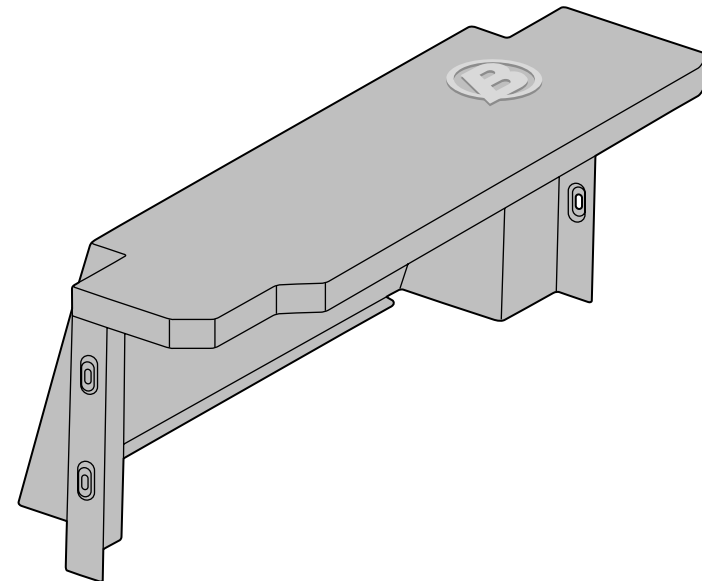

Installation

Parts List

INSTATRUNK™, Qty - 1
Instruction Sheet, Qty - 1
Weatherstripping, Qty - 1
Brass Wellnut, Qty - 4
Knob, Qty - 4
Flare Tool, Qty - 1
Screw Tool, Qty - 1

Tools Needed

Utility Knife
Safety Glasses

Step One

Tumble Rear Seat.

Open the tailgate of the vehicle and tumble the rear seat all the way forward.

Carefully pull the carpet away from the rear wheel wells so that the hook and loop remains attached to the carpet for reinstallation later.

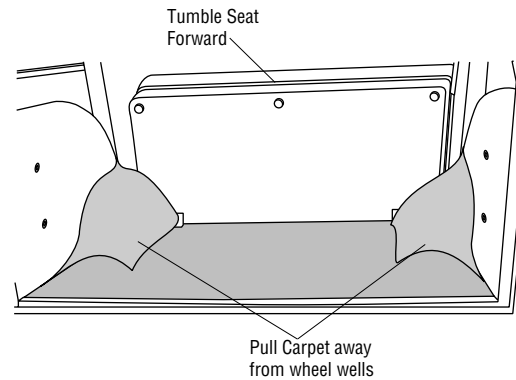

Step Two

Install the Brass Wellnuts.

Locate the two holes in the wheel wells on each side of the vehicle. They are covered by rubber plugs. Remove the plugs.

Locate the Brass Wellnuts in the parts kit. Use the tools provided to install them into the holes. Make sure that the flange of the Wellnut is completely against the metal while installing.

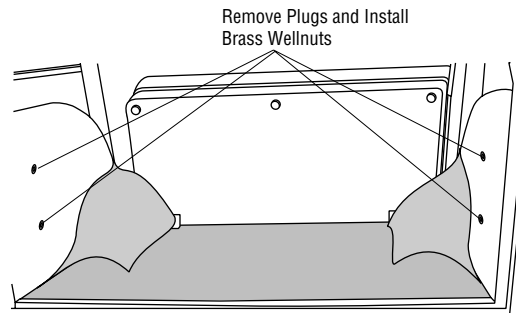

Step Three

Replace carpet.

Replace the carpet, smoothing it out and covering the Wellnuts. Use a utility knife to cut a 1" vertical slit in the carpet at each Wellnut location.

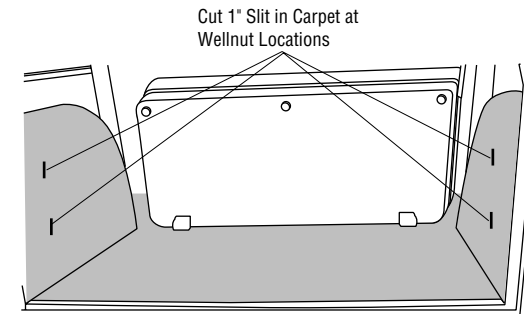

Step Four

Install INSTATRUNK™.

Place the INSTATRUNK™ in the vehicle aligning the holes in the trunk with the Wellnuts. Install a Knob through the trunk into each Wellnut.

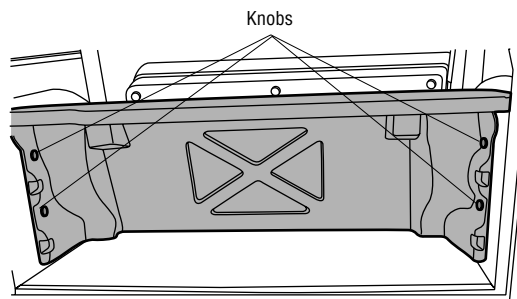

Step Five

Install Weatherstripping.

Locate the Weatherstripping in the parts kit. From the rear of the vehicle start installing the weatherstripping on the driver's side and work across to the passenger's side. Peel the backing off the weatherstripping a few inches at a time and press the adhesive on the weatherstripping onto the edge of the trunk.

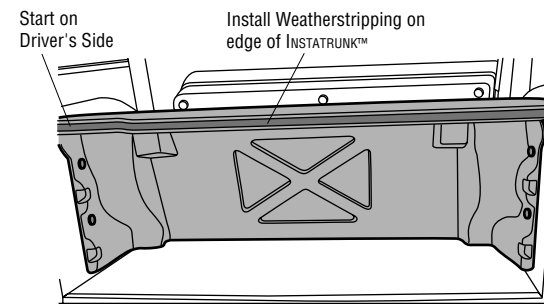

LIMITED WARRANTY

We warrant our product to be free from defects in material and workmanship, for terms specified below, provided there has been normal use and proper maintenance. This warranty applies to the original purchaser only. All remedies under this warranty are limited to the repair or replacement of any item or items found by the factory to be defective within the time period specified.

If you have a warranty claim, first you must call our factory at the number below for instructions. You must retain proof of purchase and submit a copy with any items returned for warranty work. Upon completion of warranty work, if any, we will return the repaired or replaced item or items to you freight prepaid. Damage to our products caused by accidents, fire, vandalism, negligence, misinstallation, misuse, Acts of God, or by defective parts not manufactured by us, is not covered under this warranty.

THE WARRANTY TIME PERIOD IS AS FOLLOWS: ALL "SOFT GOODS" MANUFACTURED BY OUR COMPANY (USING PRIMARILY VINYL, PLASTICS, AND/OR FOAM): ONE YEAR FROM DATE OF PURCHASE.

ANY IMPLIED WARRANTIES OF MERCHANTABILITY AND/OR FITNESS FOR A PARTICULAR PURPOSE CREATED HEREBY ARE LIMITED IN DURATION TO THE SAME DURATION AND SCOPE AS THE EXPRESS WRITTEN WARRANTY. OUR COMPANY SHALL NOT BE LIABLE FOR ANY INCIDENTAL OR CONSEQUENTIAL DAMAGE.

Some states do not allow limitations on how long an implied warranty lasts, or the exclusion or limitation of incidental or consequential damages, so the above limitations or exclusions may not apply to you.

This warranty gives you specific legal rights, and you may also have other rights which vary from state to state.

For further information or request for warranty work, please contact:

Bestop Inc.
Customer Service
(800)346-3910
(303)465-1755