



Convertible Top Installation Instructions



For: Ford Bronco '66 - '77

Part Number: 51312

Congratulations on your purchasing decision. Bestop designed the Convertible Top to give you years of dependability and performance with proper care. If you encounter any problems during the installation of your Convertible Top, or at any later date, please contact your authorized Bestop dealer or call our Consumer Response Department, Monday - Friday, 8AM-4:30PM (MST) at (800) 346-3910 or (303) 465-1755 in Colorado.

Note: Please read this manual thoroughly before beginning the installation. After completing installation, keep this manual for further reference.

WARNING

This product is designed to enhance the appearance of the vehicle and to shield the occupants from ordinary weather conditions. Do not rely, in any way, on the components of this product to contain occupants within the vehicle, or to protect against injury or death in the event of an accident. This top will not protect the occupants from falling objects. Never operate vehicle in excess of manufacturer's specifications.

WEAR SEAT BELTS AT ALL TIMES.

Read and follow, precisely, all installation instructions provided when installing top. Failure to do so may result in a poor fitting top and could place occupants of the vehicle in a potentially dangerous situation.

LIMITED WARRANTY

We warrant our product to be free from defects in material and workmanship, for the terms specified below, provided there has been normal use and proper maintenance. This warranty applies to the original purchaser only. All remedies under this warranty are limited to the repair or replacement of any item or items found by the factory to be defective within the time period specified.

If you have a warranty claim, first you must call our factory at the number below for instructions. You must retain proof of purchase and submit a copy with any items returned for warranty work. Upon completion of warranty work, if any, we will return the repaired or replaced item or items to you freight prepaid. Damage to our products caused by accidents, fire, vandalism, negligence, misinstallation, misuse, Acts of God, or by defective parts not manufactured by us, is not covered under this warranty.

THE WARRANTY TIME PERIOD IS AS FOLLOWS: ALL "SOFT GOODS" MANUFACTURED BY OUR COMPANY (USING PRIMARILY VINYL, PLASTICS, AND/OR FOAM): ONE YEAR FROM DATE OF PURCHASE.

ANY IMPLIED WARRANTIES OF MERCHANTABILITY AND/OR FITNESS FOR A PARTICULAR PURPOSE CREATED HEREBY ARE LIMITED IN DURATION TO THE SAME DURATION AND SCOPE AS THE EXPRESS WRITTEN WARRANTY. OUR COMPANY SHALL NOT BE LIABLE FOR ANY INCIDENTAL OR CONSEQUENTIAL DAMAGE.

Some states do not allow limitations on how long an implied warranty lasts, or the exclusion or limitation of incidental or consequential damages, so the above limitations or exclusions may not apply to you.

This warranty gives you specific legal rights, and you may also have other rights which vary from state to state.

For further information or request for warranty work, please contact:

Bestop Inc.
Customer Service
(800)346-3910
(303)465-1755

Before You Install

You may notice some wrinkling in the fabric of your Convertible Top when you first remove it from its shipping container. Also, there may be indentations in the windows. **Don't panic.** It is normal for the tops to do this when stored in the shipping container. The wrinkles and indentations will disappear after 48-72 hours of exposure to sunlight.

Note: You should install your Convertible Top in temperatures of 70°F (21° C) or warmer. The fabric will contract in cooler temperatures, making proper installation difficult.

You are now ready to begin the installation process.

Care and Maintenance of your Bestop Top

Your top is made of the finest materials available. To keep it looking new and for the maximum possible wear, it will need periodic cleaning and maintenance.

Washing: The top fabric should be washed often using soap, warm water and a soft bristle brush. Rinse with clear water to remove all traces of soap.

Windows: Keep windows clean to avoid scratching. DO NOT use a brush on the windows! Wash with a watersoaked cloth or sponge and a mild dishwashing detergent. NEVER WIPE THE WINDOWS WHEN THEY ARE DRY. Be careful when cleaning snow or frost from the vinyl windows since they are easily scratched and may crack at low temperatures. DO NOT roll the sides or rear curtain in cold weather. The windows become stiff and will crack.

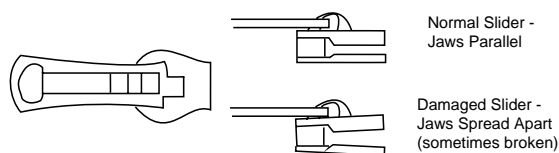

Zippers: Keeping the zipper cleaned and lubricated with a silicone lubricant will help prevent damage and keep the zippers in a smooth working condition. If a zipper opens behind the slider, the slider may have been spread apart. This problem can usually be repaired by using an ordinary pair of pliers to bring the sides back into parallel. Return slider to the end of the zipper in the normal Open position. Squeeze lightly at first and test the zipper. If the zipper continues to remain open squeeze more firmly with the pliers and try the zipper again. Repeat this procedure until the zipper operates correctly.

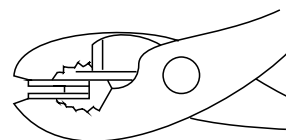

Water: Seeping through at the seams may be stopped by applying 3-M Scotchgard® on the inside of the seams. Rips in the fabric may be repaired with Bondex® iron on patches. Iron the patches to the Inside of the top, carefully following the Bondex® instructions.

Snaps: Keep snaps cleaned and lubricated with silicone to help prevent snaps from sticking to the studs. If a snap does become stuck to a stud, use a screwdriver and GENTLY pry apart to prevent permanent damage to the snap or the top fabric.

Installation: Getting Started

Your Convertible Top will require two people for proper installation.

This section will familiarize you with the parts included with your Convertible Top and will get you through the "pre-installation" steps.

Note: You should install your Convertible Top in temperatures of 70°F (21° C) or warmer. The fabric will contract in cooler temperatures, making proper installation difficult.

What You'll Need

- | | |
|---|--|
| <input type="checkbox"/> Flathead screwdriver | <input type="checkbox"/> A phillips head screwdriver |
| <input type="checkbox"/> A center punch | <input type="checkbox"/> A hammer |
| <input type="checkbox"/> 1 ea. 3/32", 5/32", and 3/16" drill bits and a power drill | <input type="checkbox"/> A piece of chalk |
| | <input type="checkbox"/> An adjustable wrench |

That's it. With these tools, you're ready to go.

Unpacking: What You Have

Remove parts carefully from the shipping container in order to avoid scratching windows. **Check each part included against the following Parts List.**

Parts List and Hardware Identification

Check off each item

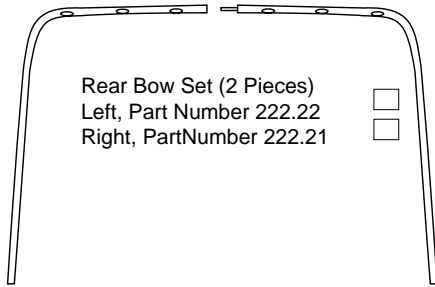

Rear Bow Set (2 Pieces)
Left, Part Number 222.22
Right, PartNumber 222.21

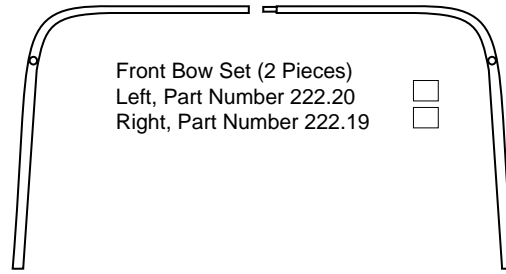

Front Bow Set (2 Pieces)
Left, Part Number 222.20
Right, Part Number 222.19

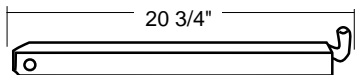

Left & Right Vertical Rods, Qty - 1 ea.,
PN, Left 149.17 & Right 149.16

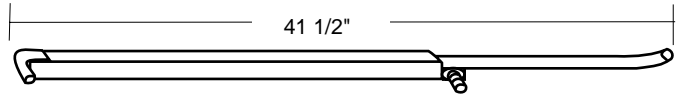

Left & Right Horizontal Rods, Qty. - 1 ea.,
PN, Left 149.12 & Right 149.11



Body Stud, Qty - 18, PN 9.68

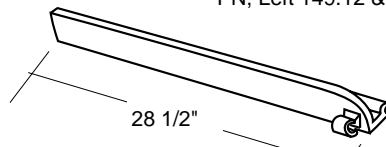

Left & Right Windshield
Adapter, Qty - 1 ea.,
PN, Left 4.66 & Right 149.23



#10 Oval Head
Screw, Qty - 4, PN
155.49



#6 S/M Screw, Qty - 18, PN 9.69



10 x 32 Hex Nut,
Qty - 12, PN 151.82

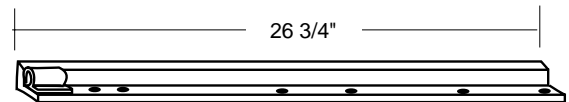

Left & Right Front Aluminium Angle,
Qty - 1 ea., PN, Left 136.47 & Right 135.96

Bow Mounting Kit, Packaged together, PN 182.76

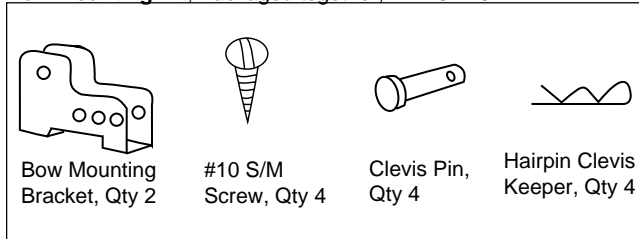

Threaded Screw Stud,
Qty - 12, PN 151.81



Footman Loop, Qty - 2,
PN 272.29



1" Plastic Rod Cap, Q
- 2, PN 151.55



5/16" Wing Nut,
Qty - 2, PN 151.83

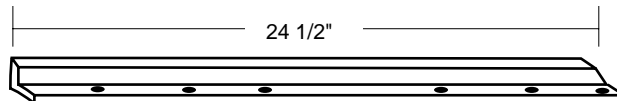

Right & Left Rear Aluminum Angle, Qty - 1
ea., PN, Right 136.48 & Left 137.46

Because of generic packaging, extra parts may be included.

Fabric Top, Qty - 1
Bow Covers, Qty - 4

The Mounting Assembly

Side Railings

Step One

Using the bolts from the factory hard top, install the aluminum angle rails in the existing holes on the top of the body edge as shown in figure 1. There should be a 3" space between the two pieces on each side for the Bow Mounting Bracket.

Figure 1

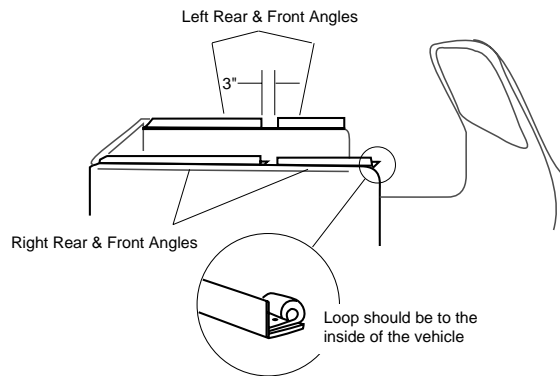

Bow Mounting Brackets

Step One

Locate one of the the Bow Mounting Brackets and place it in the space between the side railings. The outside edge of the Bracket should be flush with the railing. Mark the two outside holes.

IMPORTANT: The Bracket secures to the vehicle by using two Sheet Metal Screws. Use the two holes in each bracket which are closest to the outer edge of the body.

Figure 2

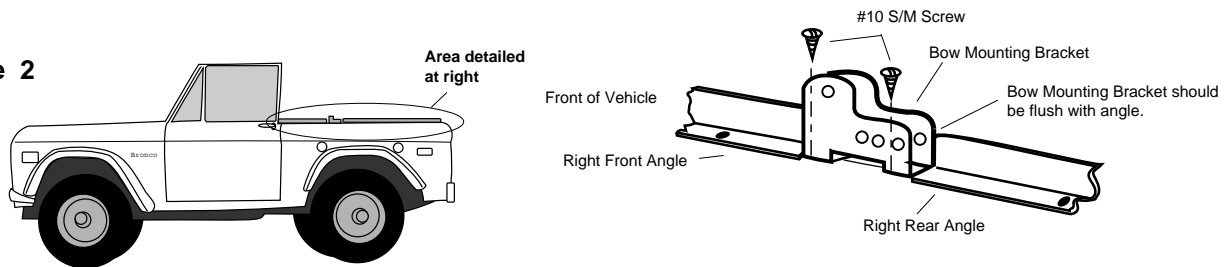

Step Two

Center punch your marks and drill 5/32" holes at these locations. Tighten the bracket in place using 2 #10 Sheet Metal Screws. See figure 2.

Windshield Adapter

Step One

Using the bolts from the factory hard top, install the two-piece Windshield Adapter to the top of the windshield frame. See figure 3. If there is any weatherstripping on the windshield it should be left in place.

Figure 3

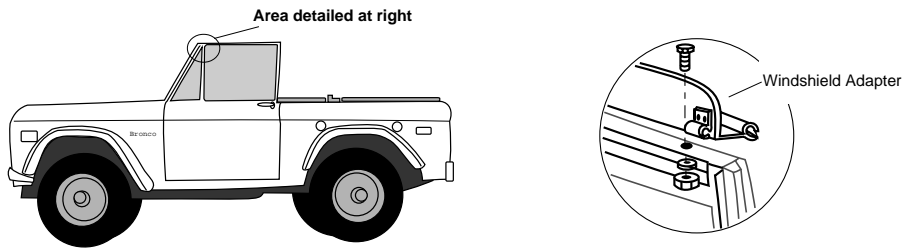

IMPORTANT: On some Bronco models there are two points on the plastic windshield wiper motor cover that extend forward and interfere with the installation of the Windshield Adapter. If this is the case with your vehicle, you will need to use the templates on page 10 to mark and cut off the cover at these points.

Front Bow Assembly

Step One

Connect the two halves of the Front Bow Assembly and slide a Bow Cover over each leg of the Bow. THE TWO LARGE HOLES IN THE FRONT BOW ASSEMBLY SHOULD FACE THE FRONT OF THE VEHICLE.

Figure 4

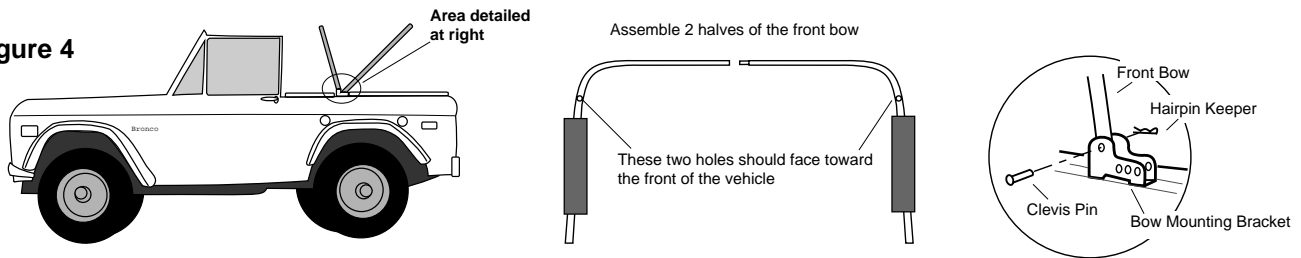

Step Two

Mount one leg of the Front Bow Assembly into the front of the Bow Mounting Bracket, using the Clevis Pin and Hairpin Keeper as shown in figure 4. Repeat this process for the other leg of the Front Bow Assembly.

Rear Bow

Step One

Connect the two halves of the Rear Bow Assembly and slide a Bow Cover over each leg of the Bow. Then install a Body Stud in each hole in the Rear Bow Assembly, using a #6 Sheet Metal Screw as shown in figure 5.

Figure 5

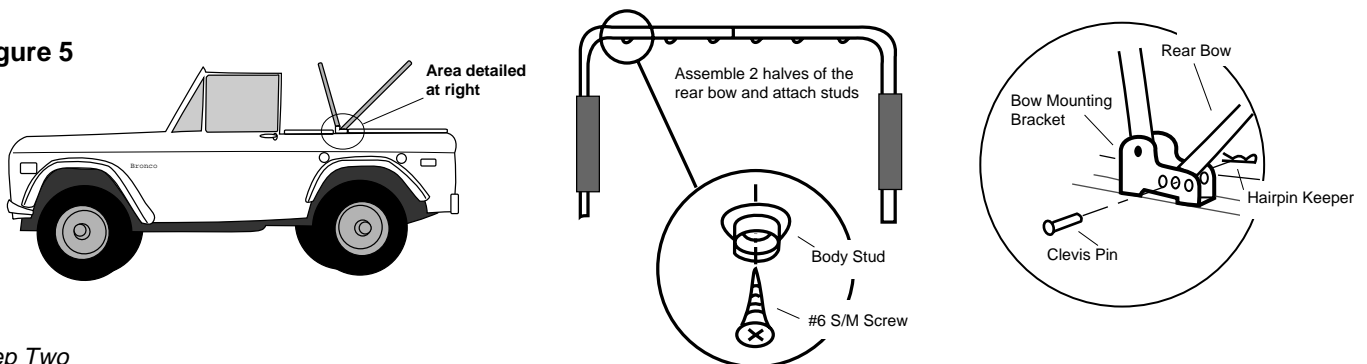

Step Two

Mount one Leg of the Rear Bow Assembly into the CENTER HOLE at the back of the Bow Mounting Bracket, using a Clevis Pin and Hairpin Keeper as shown in figure 5. Repeat this process for the other leg of the Rear Bow Assembly.

NOTE: Attach the Rear Bow to the center hole in the bracket. The other two holes adjust the tightness of the top after installation.

Horizontal and Vertical Rods

Horizontal Rod

Step One

Attach a 1" Plastic Rod Cap to the rear end of each Horizontal Rod (this is the end with the 45° bend). Insert this end into the hole in the Front Bow with the bolt to the inside of the vehicle. Insert the other end into the Windshield Adapter.

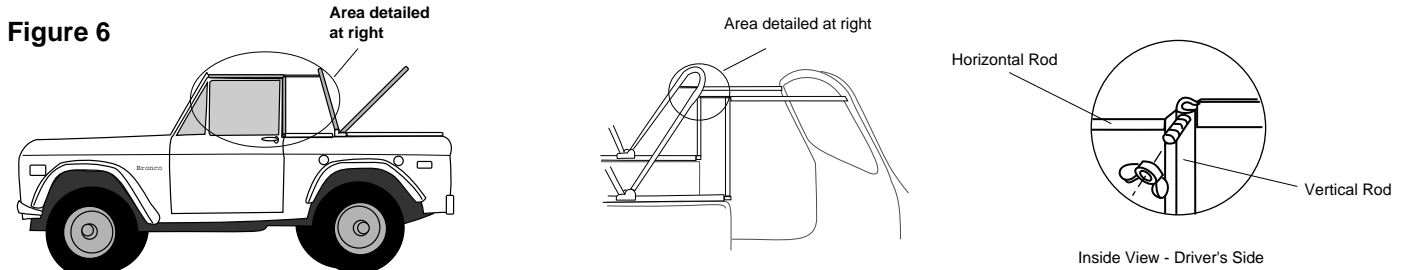

Vertical Rod

Step One

Attach the Vertical Rod to the Horizontal Rod, secure in place with a Wing Nut. See figure 6. Insert the other end into the side railing.

NOTE: At this point, check to see that the top edge of the doors close properly against the Horizontal Rod. They should just touch the rod, but not require excessive pressure to close the doors. Adjust if necessary by bending the rods.

The Top Fabric

Installing the Top Fabric

Step One

Unfold the Top and drape it over the Front Bow. Insert the Top into the Windshield Channel groove at one side and slide it in (see figure 7). Slide the Top all the way through the Channel groove so that the other seam is outside the channel. Then work that side back into the groove and center the Top.

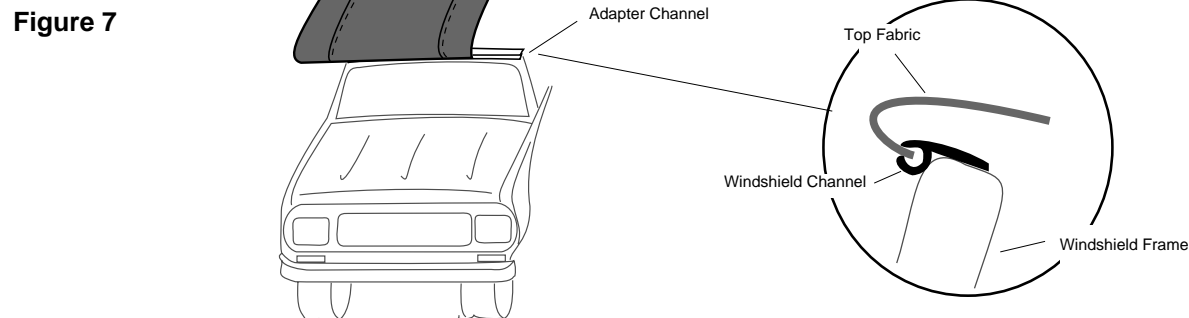

Step Two

Lift the Rear Bow and drape the Top over it. Snap the flaps on the inside of the Top to the Body Studs on the Rear Bow. Fold the fabric flap around the Horizontal and Vertical Rods. Fasten them by pressing the pieces of Hook and Loop Strip together. Zip the rear curtain closed.

Installing the Body Studs

The following steps are crucial to the proper installation of your Top. You will need to have a friend help you to ensure even tightness and fit of the top. Make sure the Top is as warm as possible before beginning.

Step One

Close all zippers on the side and rear curtains of the Top.

Step Two

Mark the locations for the 2 rear snaps on each side panel (see figure 8). Do this by rubbing chalk on the snaps at the inside of the Top. Place 1 stud on the rear of the Aluminum Angle and 1 next to the tailgate opening. Pull down and to the rear, making sure that the side panel comes around the corner and close to the tailgate opening, **without interfering with tailgate operation**.

Figure 8

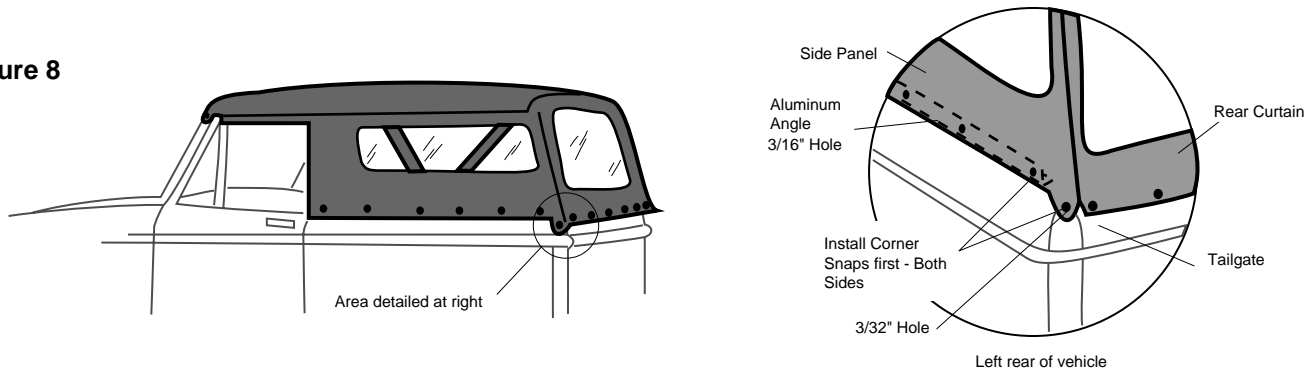

TO INSURE A GOOD FIT, HAVE YOUR FRIEND PULL DOWN ON THE REAR BOW WHILE YOU PULL THE FABRIC DOWN AND TO THE REAR TO LOCATE THE TWO REAR CORNER STUDS. IF PULLING THE FABRIC INTO POSITION IS EXTREMELY DIFFICULT, TIGHTNESS CAN BE ADJUSTED BY MOVING THE REAR BOW INTO THE FRONT HOLE IN THE BOW MOUNTING BRACKET.

When you are satisfied with the tightness of the Top, press the snaps against the vehicle. The chalk will leave marks for Body Stud positions. Center punch the marks and drill 3/16 inch holes at the marked locations in the Aluminum Angle. Install a Threaded Screw Stud and a Hex Nut. Drill a 3/32 inch hole in the body and install a Body Stud in the rear corners with #6 Sheet Metal screws. Now snap the Top down at the corners.

Step Three

Now move to the front of the side panels. Pull the Top Fabric down and forward to eliminate wrinkles and to insure a proper fit. Install Threaded Screw Studs and Hex Nuts in the Aluminum Rails next to the door openings here and on the opposite side. Snap the top to each new stud.

Figure 9

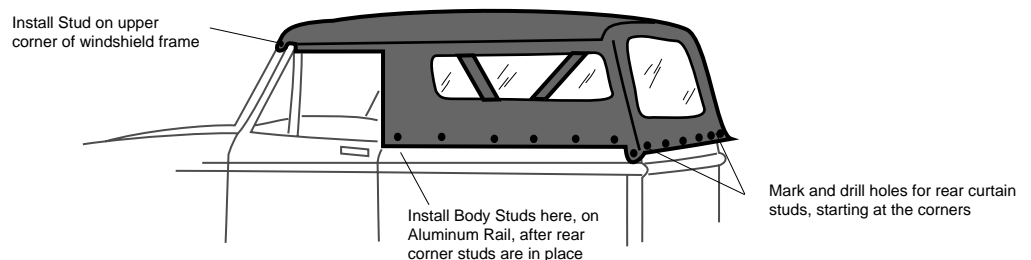

Step Four

Install the remaining studs in the side panels. Alternate from side to side as you install the studs and snap the Top down. This will keep the tension evenly spread.

Step Five

On the rear curtain, mark the locations of the snaps, starting with the outside corners by pulling down and to the outside to eliminate wrinkles. Punch and drill 3/32 inch holes at these locations and install Body Studs with #6 Sheet Metal Screws. Snap the rear curtain down. See figure 9.

Step Six

Locate the snap tab on the front corner of your top. Pulling the fabric forward and down, to eliminate wrinkles, mark the location for the Body Studs. Drill 3/32 inch holes and install the Body Studs with #6 Sheet Metal Screws.

Step Seven

Install the two Footman Loops on the inside rear of the vehicle near the corners, but NOT on the tailgate. Drill 5/32 inch holes and secure the Footman Loops in place with #10 Oval Head Screws. See Figure 10.

Figure 10

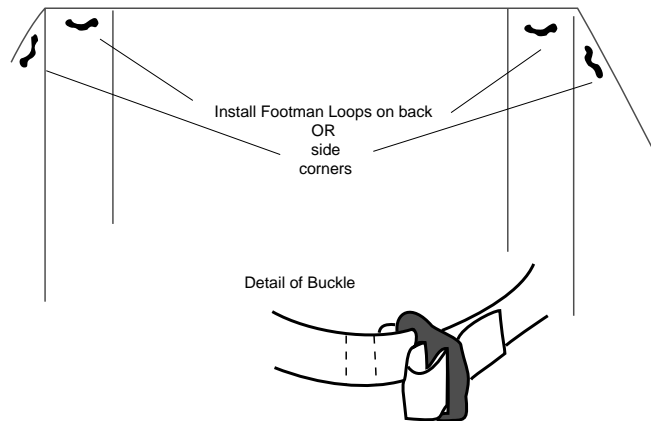

Thread the long strap attached to the Top through the loops and then the buckle. This strap will hold down the Rear Bow when the rear

Adjusting and Storing the Top

Rolling the Rear and Side Curtains

Step One

To roll the rear curtain, start at the bottom and roll to the inside (see figure 11 below), avoiding wrinkles in the fabric and windows. Secure with Curtain Strap.

Figure 11

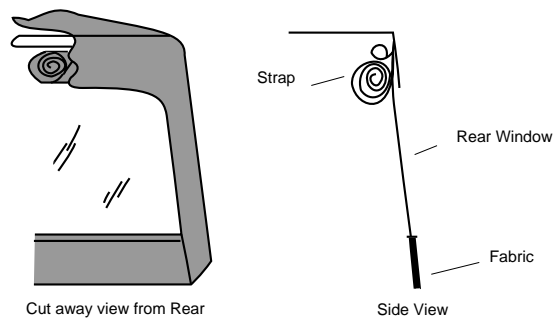

Step Two

To roll the side curtains, you must first remove the Vertical Rod and unzip the curtains. Then use the same procedure as for the rear curtain, except you must first make a vertical fold at the rear corner to bring the triangular piece of fabric to the inside.

Figure 12

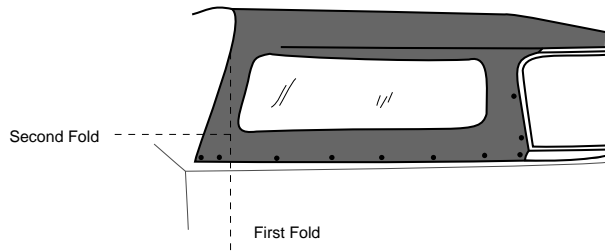

Folding the Top Down

Step One

Unsnap the rear and side curtains and unzip the rear curtain zippers. Then remove both the Vertical and Horizontal Rods. Unfasten the Top from the Front Bow Assembly and push the Front Bow toward the Rear Bow.

Step Two

Fold the side curtain up over the Top, folding along the seam. Then fold the rear curtain up over the side curtains (see figure 13).

Figure 13

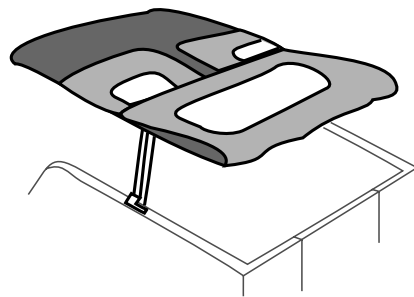

Step Three

Unfasten the Top from the windshield and lower the Top onto the vehicle as you push both Bows down and to the rear (see figures 14 and 15). Smooth out wrinkles and fold the Top in half from front to rear. You may then roll the Top to the back if you wish to keep it in the vehicle, or you may remove the Bows from their mounting bracket by removing the clevis pins and hairpin keepers.

Figure 14

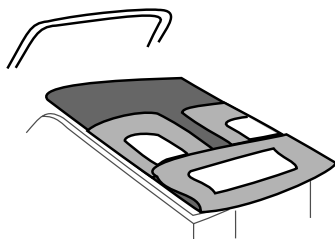
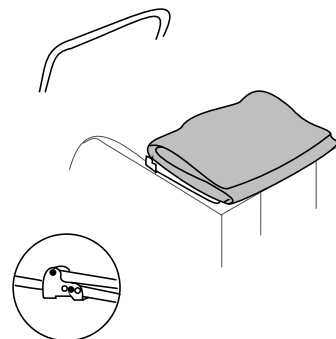

Figure 15



Storing the Top

Place sheets of paper over each window before storing. This will protect against scratches. Store the Top by folding and removing from vehicle. Keep the Top stored in its original shipping container in a cool, dry place.

If the Top is to be kept on the vehicle, roll carefully toward the rear and store in a Top Boot, or fasten securely with a nylon rope or straps. Leave attached to the Rear Bow. If you do not want the Rear Bow laying on the spare tire, you may remove the Clevis Pin and Keeper from Rear Bow and slide the Bow under the Front Bow in the Bow Mounting Bracket. Re-secure the Bow to the Bow Mounting Bracket with the Clevis Pin and Keeper.

TEMPLATES FOR WINDSHIELD WIPER COVER

Cut out the template and position it on the wiper motor cover. Mark the cover along the straight edge of the template. Cut the cover along the line.

