



BESTOP
www.bestop.com

Trail Cover Installation Instructions

For: 1992 - 1995 Wrangler

Part Number: 81030

Special Note: This Trail Cover is to be installed on the vehicle without a complete top in place. The bows should be folded down if installation is on a soft top Wrangler.

This Trail Cover may be installed over a Duster and Bikini.

The adjustable straps are designed to fit the "stock" model, and may not latch to various steps and rocker guards added to vehicle.

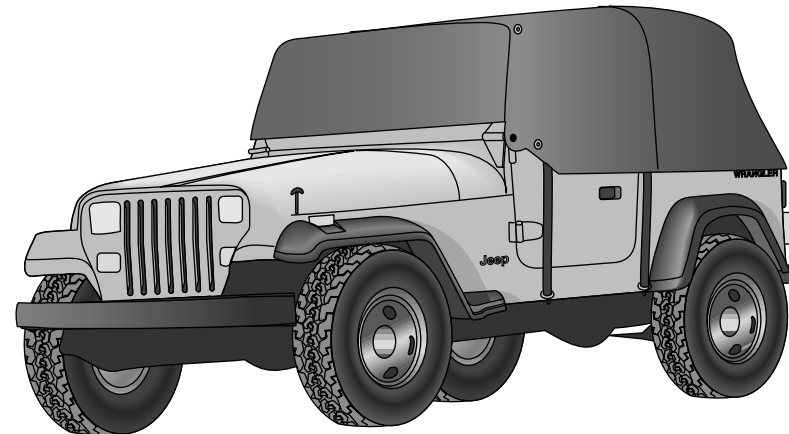

WARNING

This Trail Cover is designed primarily to protect the interior of the vehicle from ordinary weather conditions. Please note that during prolonged exposure to heavy rain or snow, some seam leakage may occur. Please plan accordingly. This Trail Cover will not protect the vehicle from falling objects. Never operate vehicle with Trail Cover installed. The Trail Cover is not made to cover vehicle while vehicle is in tow.

Installation Tips

Before you begin installing this Trail Cover, read all instructions thoroughly. Below are a few tips to make this installation easier.

Note:

It is normal for the fabric to contract and wrinkle when stored in the shipping carton. Within a few days after the installation, the fabric will relax and the wrinkles will disappear.

Trail Cover Installation

Parts List

Trail Cover Fabric Qty - 1

Preparing the Vehicle for Installation of the Trail Cover

- Make certain that the vehicle engine and all lights are turned off.
- Set the Emergency (Parking) Brake.
- Remove all personal possessions from the vehicle.

Step One

Orient the Trail Cover with the snaps towards the front and the Bestop label on the drivers side. Drape the Trail Cover over the vehicle.

Slip the grommet in the cover, above each door, over the protrusion on the Horizontal Rod on each side of the vehicle (original equipment soft top hardware only).

If you have a metal half door on your vehicle, snap the front of the Trail Cover to the snap on the front of the door.

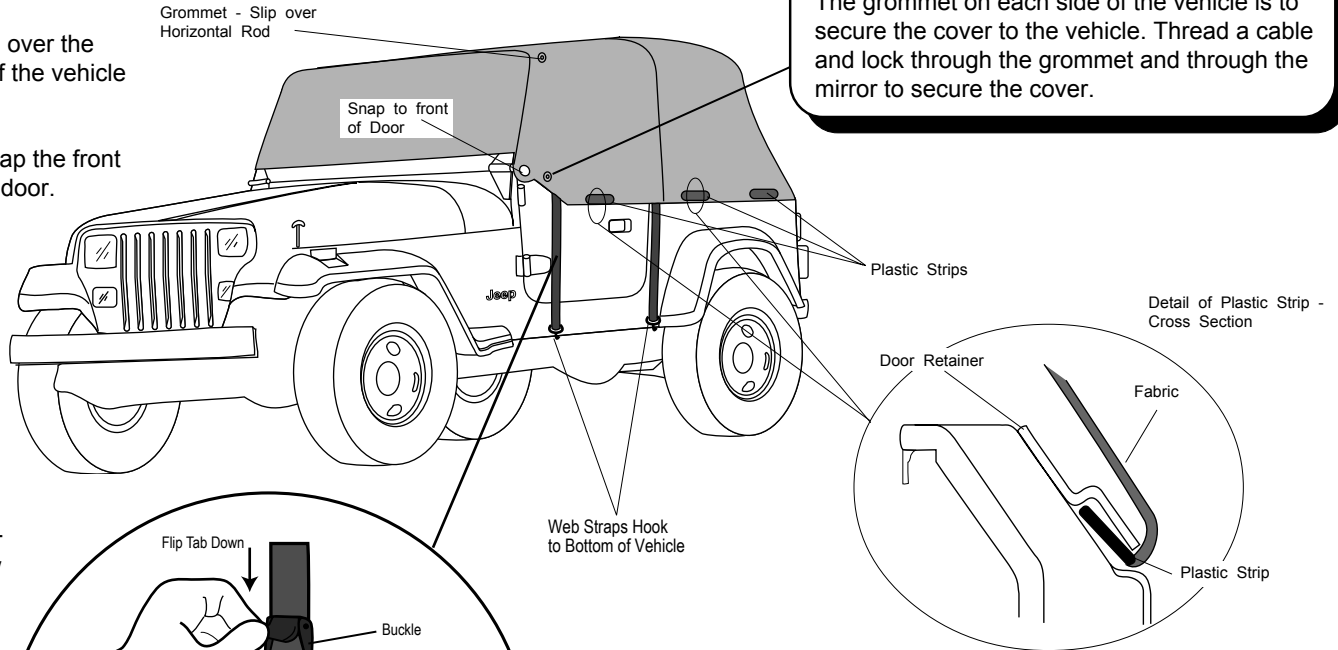

Optional:
The grommet on each side of the vehicle is to secure the cover to the vehicle. Thread a cable and lock through the grommet and through the mirror to secure the cover.

Step Two

Locate the two web straps sewn on each side of the Trail Cover. Pull the straps down and hook them to the bottom of the vehicle. Tighten the straps by pulling up the disengaged buckle. Secure the buckle by flipping the tab of the buckle down.

Make sure that the fabric flap inside the cover lays flat behind the grommets, next to the snap, on each side of the vehicle.

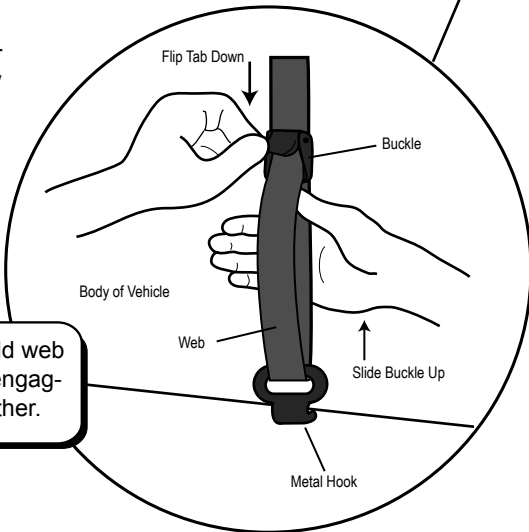

For ease of installation: Firmly hold web and buckle up with one hand while engaging the buckle lever down with the other.

Step Three - Optional (Soft Top Vehicles Only)

There are three plastic strips sewn to each side of the Trail Cover. Slip the front plastic strip into the retainer along the top of the metal half door and slip the two rear plastic strips into the belt rail retainer on the side of the vehicle.

Note:
If you have a Duster installed on your vehicle, use only the side web straps and the rear elastic straps to hold the Trail Cover in place.



Step Four

Locate the three elastic loops sewn to the rear of the Trail Cover (one small loop on each side of the vehicle and one large loop in the center). Hook the two outside loops around the taillights and hook the center loop around the tire carrier.

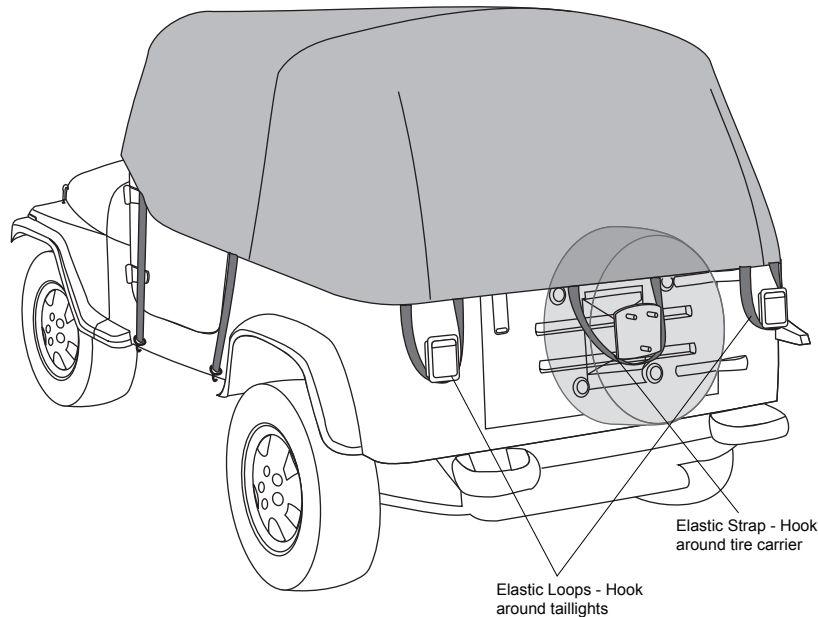

Care and Maintenance of your Bestop Cover

Your cover is made of the finest material available. To keep it looking new and for the maximum possible wear, it will need periodic cleaning and maintenance.

Washing: The fabric should be washed often using soap, warm water and a soft bristle brush. Rinse with clear water to remove all traces of soap.

Water: Seeping through at the seams may be stopped by applying 3-M Scotchgard® on the inside of the seams. Rips in the fabric may be repaired with Bondex® iron on patches to the Inside of the top, carefully following the Bondex® instructions.

Snaps: Keep snaps cleaned and lubricated with silicone to help prevent snaps from sticking to the studs. If a snap does become stuck to a stud, use a screwdriver and GENTLY pry apart to prevent permanent damage to the snap or the fabric.

LIMITED WARRANTY

We warrant our Trail Cover to be free from defects in material and workmanship, for the terms specified below, provided there has been normal use and proper maintenance. This warranty applies to the original purchaser only. All remedies under this warranty are limited to the repair or replacement of any item or items found by the factory to be defective within the time period specified.

If you have a warranty claim, first you must call our factory at the number below for instructions. You must retain proof of purchase and submit a copy with any items returned for warranty work. Upon completion of warranty work, if any, we will return the repaired or replaced item or items to you freight prepaid. Damage to our products caused by accidents, fire, vandalism, negligence, misinstallation, misuse, Acts of God, or by defective parts not manufactured by us, is not covered under this warranty.

THE WARRANTY TIME PERIOD IS AS FOLLOWS: ALL "SOFT GOODS" MANUFACTURED BY OUR COMPANY (USING PRIMARILY VINYL, PLASTICS, AND/OR FOAM): ONE YEAR FROM DATE OF PURCHASE.

ANY IMPLIED WARRANTIES OF MERCHANTABILITY AND/OR FITNESS FOR A PARTICULAR PURPOSE CREATED HEREBY ARE LIMITED IN DURATION TO THE SAME DURATION AND SCOPE AS THE EXPRESS WRITTEN WARRANTY. OUR COMPANY SHALL NOT BE LIABLE FOR ANY INCIDENTAL OR CONSEQUENTIAL DAMAGE.

Some states do not allow limitations on how long an implied warranty lasts, or the exclusion or limitation of incidental or consequential damages, so the above limitations or exclusions may not apply to you.

This warranty gives you specific legal rights, and you may also have other rights which vary from state to state.

For further information or request for warranty work, please contact:

Bestop Inc.
Customer Service
(800)845-3567
(303)465-1755

*All or a portion of this product may be made in China.