



BESTOP
www.bestop.com

Trail Cover Installation Instructions

For: "TJ" Wrangler Unlimited '04 - '05

Part Number: 81034

Special Note: This Trail Cover is to be installed on the vehicle without a complete top in place. The bows should be folded down if installation is on a soft top Wrangler.

This Trail Cover may be installed over a Duster and Bikini.

The adjustable straps are designed to fit the "stock" model, and may not latch to various steps and rocker guards added to vehicle.

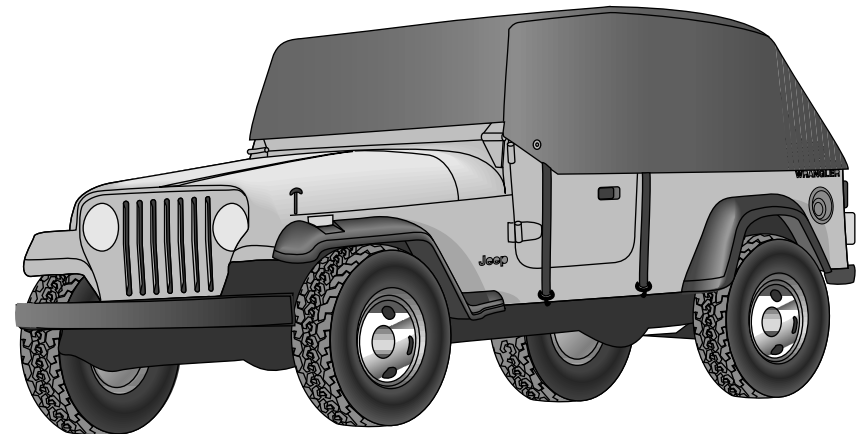

WARNING

This Trail Cover is designed primarily to protect the interior of the vehicle from ordinary weather conditions. Please note that during prolonged exposure to heavy rain or snow, some seam leakage may occur. Please plan accordingly. This Trail Cover will not protect the vehicle from falling objects. Never operate vehicle with Trail Cover installed. The Trail Cover is not made to cover vehicle while vehicle is in tow.

Installation Tips

Before you begin installing this Trail Cover, read all instructions thoroughly. Below are a few tips to make this installation easier.

Note:

It is normal for the fabric to contract and wrinkle when stored in the shipping carton. Within a few days after the installation, the fabric will relax and the wrinkles will disappear.

Parts List	
Trail Cover Fabric	Qty - 1

Trail Cover Installation

- Preparing the Vehicle for Installation of the Trail Cover**
- Make certain that the vehicle engine and all lights are turned off.
 - Set the Emergency (Parking) Brake.
 - Remove all personal possessions from the vehicle.

Step One

Orient the Trail Cover with the three loops towards the rear of the vehicle. Drape the Trail Cover over the vehicle.

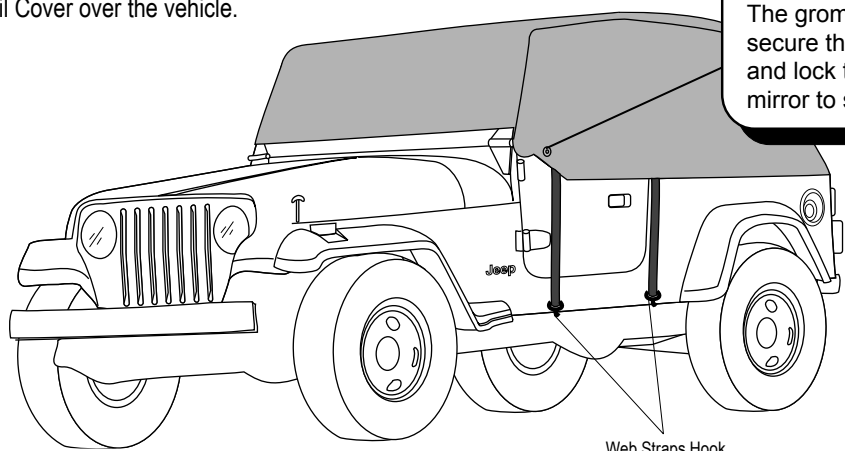

Optional:
The grommet on each side of the vehicle is to secure the cover to the vehicle. Thread a cable and lock through the grommet and through the mirror to secure the cover.

Web Straps Hook to Bottom of Vehicle

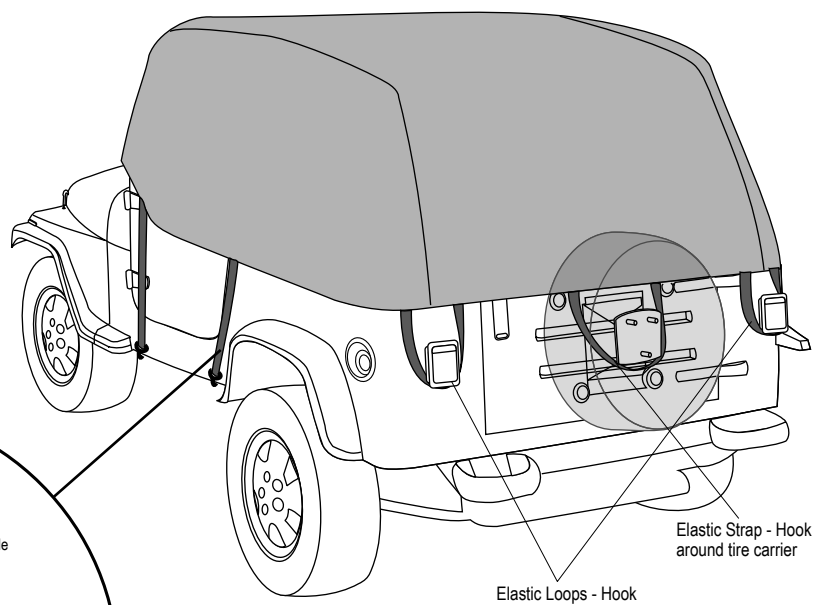

Elastic Strap - Hook around tire carrier

Elastic Loops - Hook around taillights

Step Two

Locate the two web straps sewn on each side of the Trail Cover. Pull the straps down and hook them to the bottom of the vehicle. Tighten the straps by pulling up the disengaged buckle. Secure the buckle by flipping the tab of the buckle down.

Make sure that the fabric flap inside the cover lays flat behind the grommets, on each side of the vehicle.

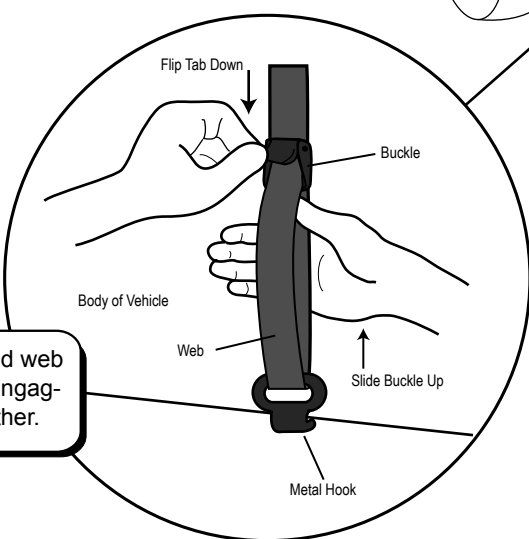

For ease of installation: Firmly hold web and buckle up with one hand while engaging the buckle lever down with the other.

Step Three

Locate the three elastic loops sewn to the rear of the Trail Cover (one small loop on each side of the vehicle and one large loop in the center). Hook the two outside loops around the taillights and hook the center loop around the tire carrier.



LIMITED WARRANTY

We warrant our Trail Cover to be free from defects in material and workmanship, for the terms specified below, provided there has been normal use and proper maintenance. This warranty applies to the original purchaser only. All remedies under this warranty are limited to the repair or replacement of any item or items found by the factory to be defective within the time period specified.

If you have a warranty claim, first you must call our factory at the number below for instructions. You must retain proof of purchase and submit a copy with any items returned for warranty work. Upon completion of warranty work, if any, we will return the repaired or replaced item or items to you freight prepaid. Damage to our products caused by accidents, fire, vandalism, negligence, misinstallation, misuse, Acts of God, or by defective parts not manufactured by us, is not covered under this warranty.

THE WARRANTY TIME PERIOD IS AS FOLLOWS: ALL "SOFT GOODS" MANUFACTURED BY OUR COMPANY (USING PRIMARILY VINYL, PLASTICS, AND/OR FOAM): ONE YEAR FROM DATE OF PURCHASE.

ANY IMPLIED WARRANTIES OF MERCHANTABILITY AND/OR FITNESS FOR A PARTICULAR PURPOSE CREATED HEREBY ARE LIMITED IN DURATION TO THE SAME DURATION AND SCOPE AS THE EXPRESS WRITTEN WARRANTY. OUR COMPANY SHALL NOT BE LIABLE FOR ANY INCIDENTAL OR CONSEQUENTIAL DAMAGE.

Some states do not allow limitations on how long an implied warranty lasts, or the exclusion or limitation of incidental or consequential damages, so the above limitations or exclusions may not apply to you.

This warranty gives you specific legal rights, and you may also have other rights which vary from state to state.

For further information or request for warranty work, please contact:

Bestop Inc.
Customer Service
(800)845-3567
(303)465-1755

*All or a portion of this product may be made in China.

