







Installation Instructions EZ Roll Tonneau

Vehicle Application:

- Chevrolet Silverado / Sierra
8' Bed
07- 13 1500 & 2014 HD
Part Number: 19210

www.Bestop.com - We're here to help! Visit our web site and click on "[Ask a Question](#)". Click here for more [Truck Accessories by Bestop](#).

INSTALLATION TIME	SKILL LEVEL
 1/2 Hour	 1 - Easy

TOOLS		
 Wrench 1/2"	 Scissors	 Safety Glasses

NOTE Wash vehicle to ensure that no dirt or abrasive materials are caught between the truck's finish and the Tonneau Rail Frame.

Check and secure all clamps to bed frame as indicated in the installation instructions before operating your vehicle.

Tonneau cover clamps must be securely attached prior to vehicle operation.

Secure retaining straps when cover is in open position.

 **CAUTION** Safety glasses should be worn at all times while installing this product.

Installation Tips

Before you begin installing this assembly, read all instructions thoroughly.

For a smooth fit:

For ease in installation, the product should be installed at temperatures above 72° F. Below this temperature, the fabric may contract an inch or more, making it difficult to fit to the vehicle. It is normal for fabric to contract and wrinkle when stored in the shipping carton. Within a few days after the installation, the fabric will relax and the wrinkles will disappear.

 **WARNING** The buckle of each retaining strap and both clamps must be fastened securely to avoid damage to personal property or possible personal injury.

If the vehicle has an Over-the-Rail Bedliner, use a certified installer to perform the initial installation. Modifications to the Bedliner may be required.

EZ Roll Tonneau Installation Instructions

Parts List

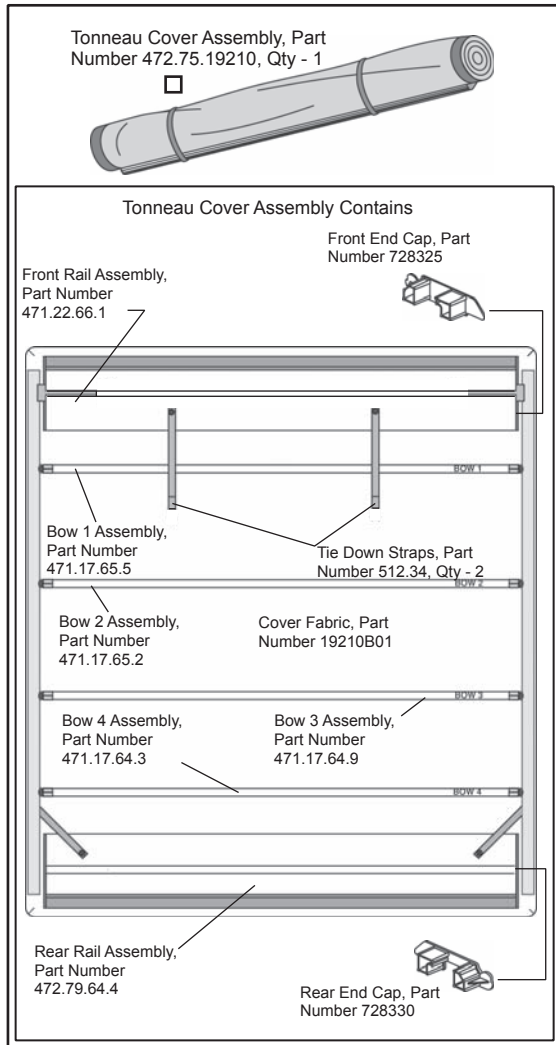

10" Foam Tape, Part Number 501.31, Qty - 2

1/2" Foam Corner, Part Number 720174, Qty - 2

5/16" Bolt, Part Number 726815, Qty - 6

Inner Clamp, Part Number 728045, Qty - 6

Outer Clamp, Part Number 728030, Qty - 6

Left Side Rail, Part Number 471.21.96.8 Qty - 1

Corner, Part Number 728300

Latch Assembly, Part Number 512.30

Corner, Part Number 728305

Corner, Part Number 728305

Corner, Part Number 728300

Right Side Rail, Part Number 471.20.96.8 Qty - 1

Latch Assembly, Part Number 512.33

Without Bed Rail Caps

1 Install 10" Foam Tape and 1/2" Foam Corners on Side Rails

Install a piece of 10" Foam Tape on the rear end of each Side Rail. Make sure the tape is flush with the end of the rail and the outside edge of the Side Rail.

Remove the 3/8" foam pad from the corner of each Side Rail and replace it with the 1/2" Foam Corner.

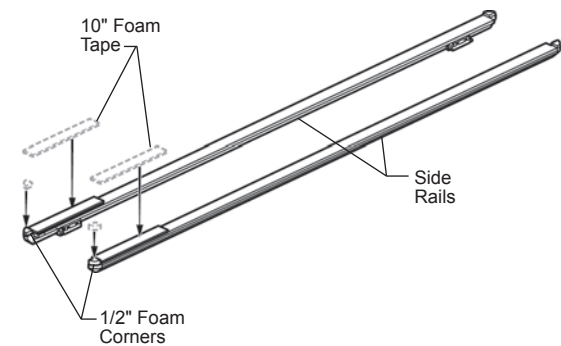

EZ Roll Tonneau Installation Instructions

2 Assemble Clamps

Use a 5/16" Bolt to secure an Outer Clamp to an Inner Clamp. Repeat for six (6) assemblies.

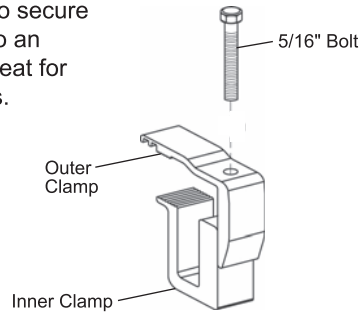

3 Place Side Rails on Bed

Locate the 2 side rails. Remove the protective tape on the bottom of each rail and place the rail on the bed on each side of the vehicle.

Once the rails are on the bed, align the front edge of each Side Rail, with the inside edge of the front bulkhead.

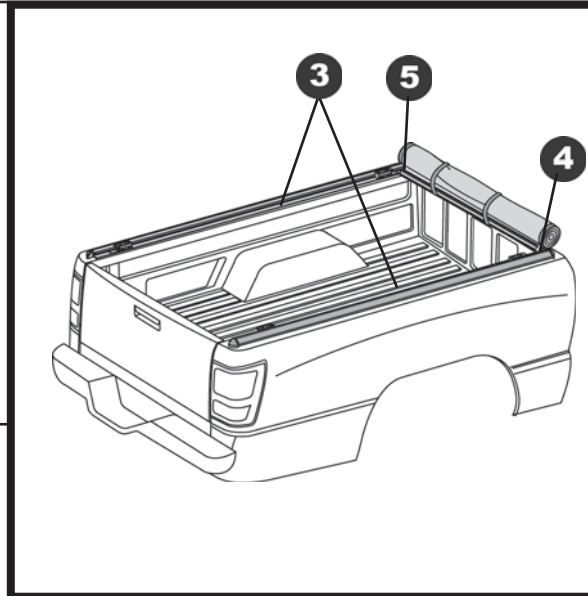
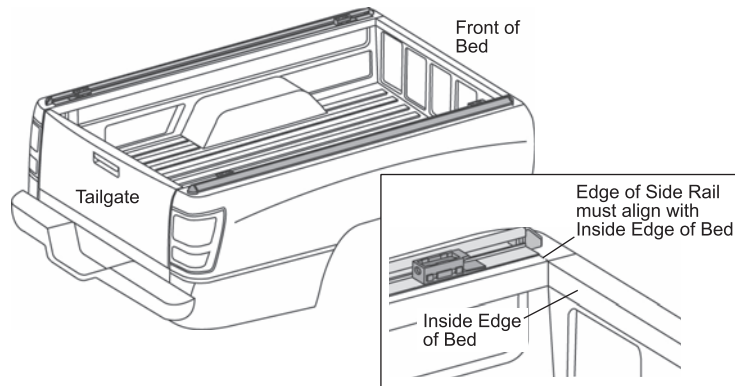

4 Secure Tonneau Cover Assembly to Passenger Side Rail

Place the Tonneau Cover Assembly into the front pivot on the Passenger Side Rail. Engage the cover assembly latch into the slot on the Side Rail. Make sure that the cover assembly is flush against the Side Rail.

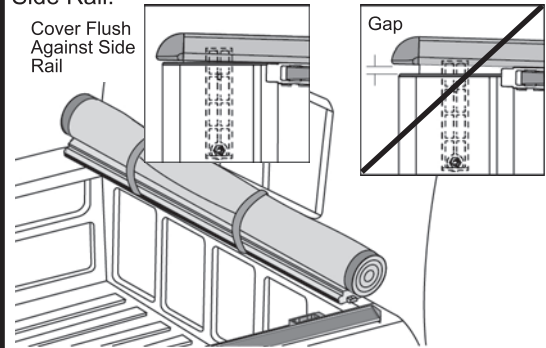

5 Secure Driver Side Rail to Tonneau Cover Assembly

Place the Driver's Side Rail into the Tonneau Cover Assembly. Make sure the cover assembly latch is fully engaged into the slot on the Side Rail and that the cover assembly is flush against the Side Rail.

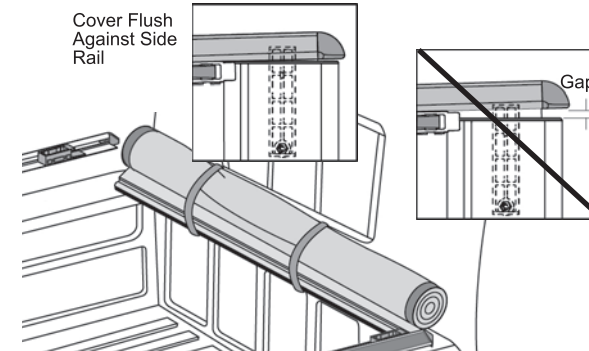

EZ Roll Tonneau Installation Instructions

6 Place Clamps

Place the front clamp on the Side Rail 6" behind the front pivot mount. Place the rear clamp 6" in front of the rear pivot mount. Locate the center of the Side Rail and place the center clamp either 6" in front of this point or 6" behind it as needed for your vehicle.

Do Not Tighten the Clamps at this time.
Repeat on both sides of the vehicle.

NOTE Clamp positions may vary depending on any bed accessories you may have.

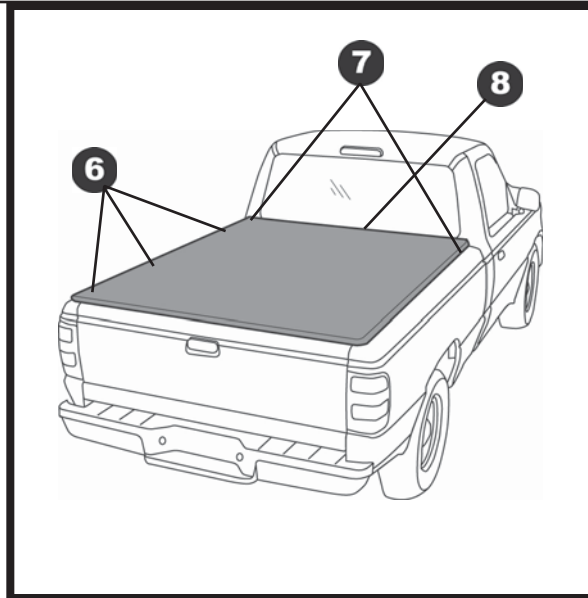

7 Unbuckle Straps

Unbuckle the Tie Down Straps.

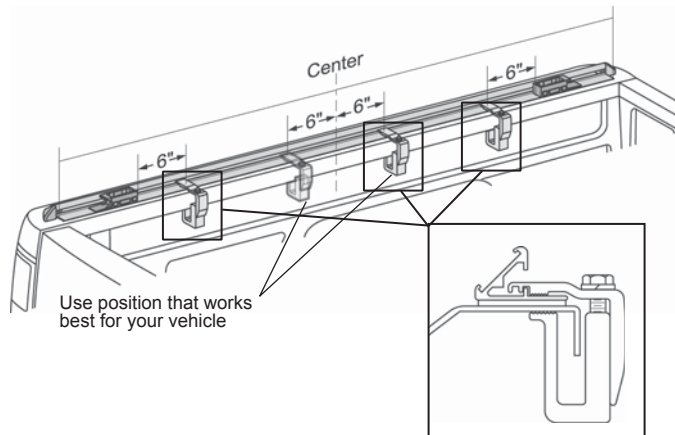
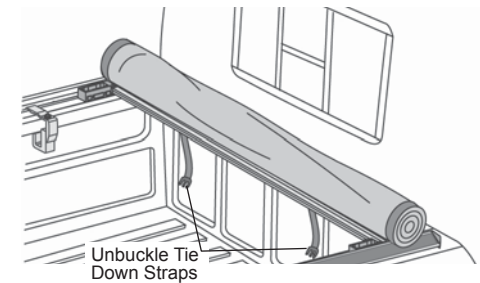

8 Center Tonneau Frame

With the Tonneau Cover Assembly latched on both sides, push both Side Rails in so they are flush with the Front Rail. Center the front of the Frame from side to side on the vehicle.

NOTE For proper function, it is best to leave a 1/8" gap between the Side Rail and the Front Rail.

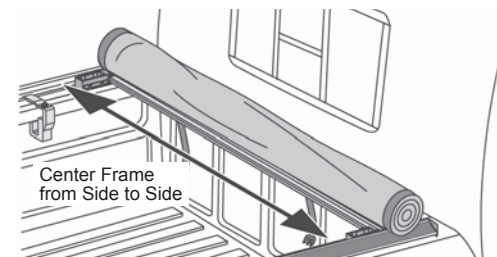

EZ Roll Tonneau Installation Instructions

9 Tighten Front Clamps

Tighten the front Clamp on each side until the Lock Washer is compressed.

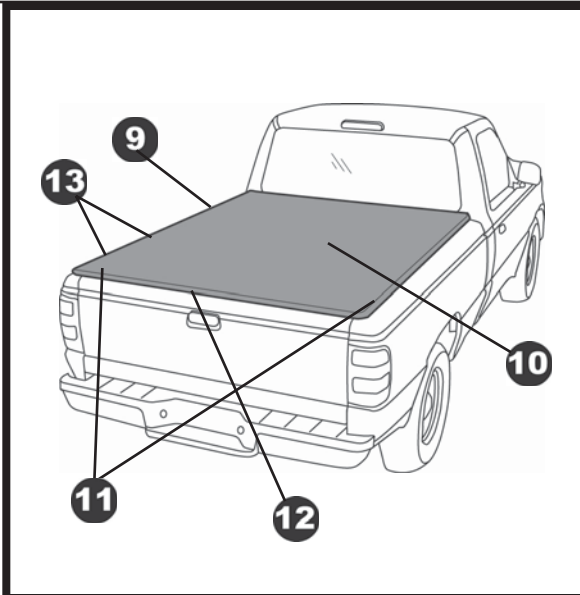
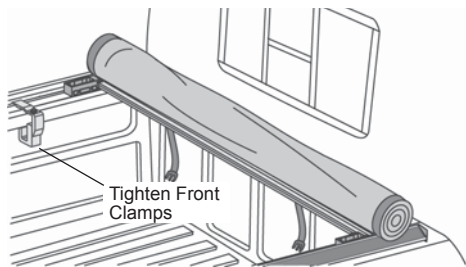

12 Center Rear of Frame

Push the Side Rails flush against the Rear Rail and center the rear of the Frame from side to side on the vehicle.

NOTE For proper function, it is best to leave a 1/8" gap between the Side Rail and the Rear Rail.

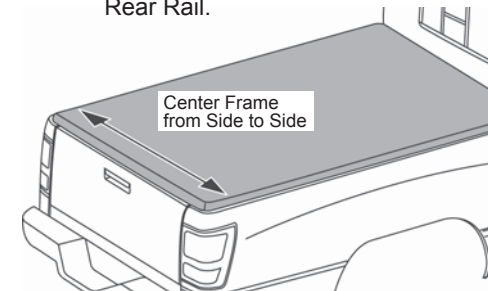

10 Roll Out Cover

Roll out the cover. Make sure that each bow falls between the Side Rails.

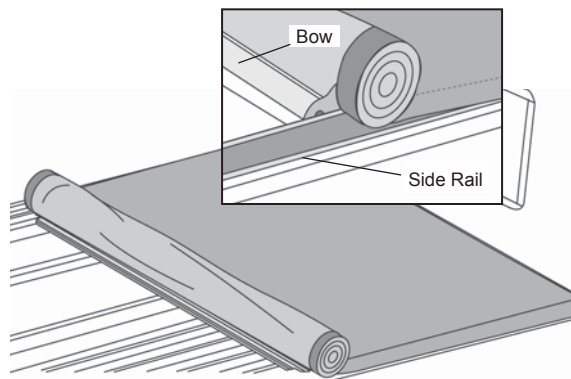

11 Secure Rear Rail To Rear Pivot Mounts

Rotate the Rear Rail into the rear Pivot Mounts on both sides. It will only latch on the driver's side.

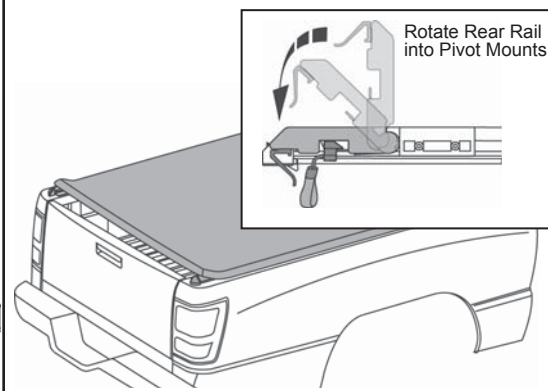

13 Secure Remaining Clamps

Once the Frame is centered reach between the cover and the Side Rail to access the center and rear clamps. Tighten the 5/16" Bolt in the Clamp until the Lock Washer is compressed, then add 1 to 1-1/2 additional turns to reach optimum pressure. Repeat on both sides of the vehicle.

NOTE Do not remove the cover until all clamps are tight.

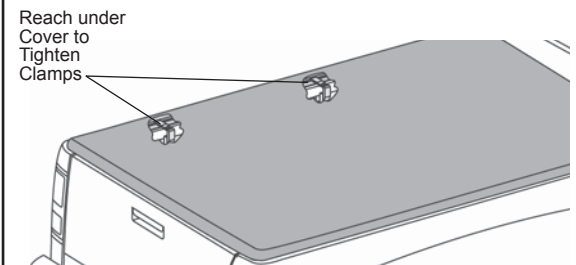

EZ Roll Tonneau Installation Instructions

14 Secure Sides of Cover

Fasten the loop strip sewn to the driver's side of the Tonneau Cover to the hook on the Side Rail. Pull the fabric tight across and secure the passenger side.

NOTE Make sure to keep the fabric tight across the bed to ensure a proper fit.

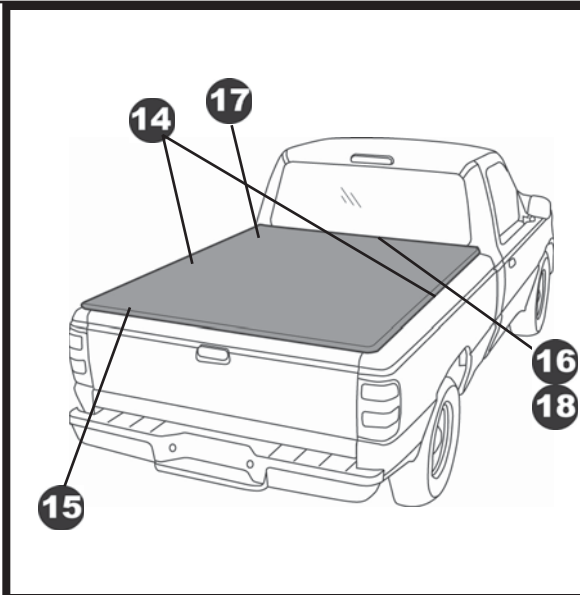
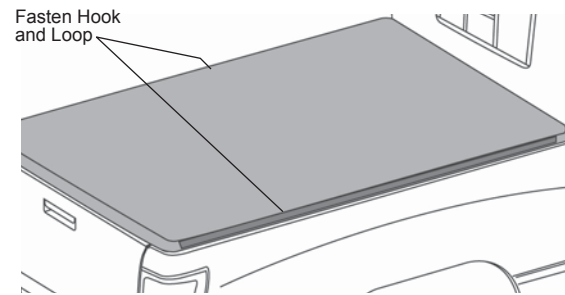

17 To Remove Cover – Loosen Side Rail

Loosen the front and middle clamps on the Driver's Side Rail. Pull outward on the rail until the cover disengages from the Side Rail.

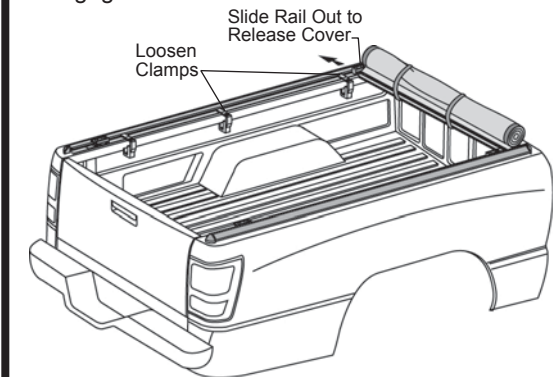

15 To Remove Cover – Release Latches

Open the tailgate and pull both the driver's side latch and the passenger side latch to rear of vehicle.

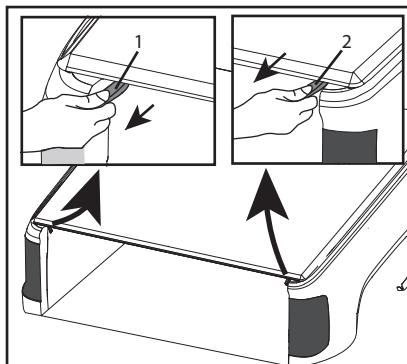

16 To Remove Cover – Roll Cover

Tightly roll the Cover toward the front and buckle the Tie Down Straps.

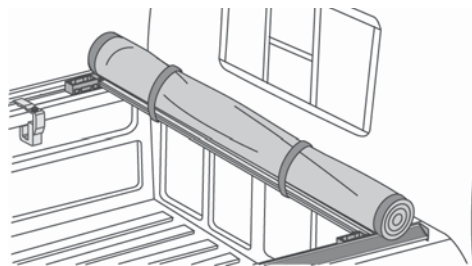

18 Remove Cover

Remove the Cover Assembly from the vehicle.

NOTE Once the Cover is removed, retighten the clamps on the Side Rail.

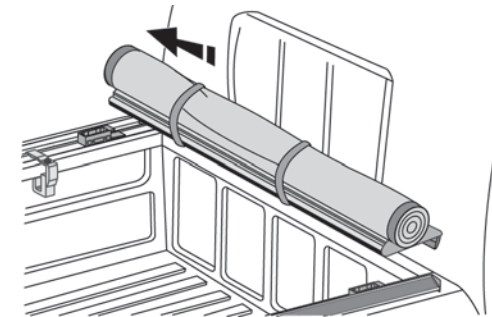

EZ Roll Tonneau Installation Instructions

19 Special Instructions – Bed Liners

If your vehicle is equipped with a Bed Liner that comes up over the front bulkhead, you will need to trim the seal on the Tonneau Cover Assembly. Mark the seal at each end of the of the Bed Liner and use scissors to trim the bottom, “eyelash”, part of the seal at the mark.

NOTE Only trim the bottom, “eyelash”, part of the seal.

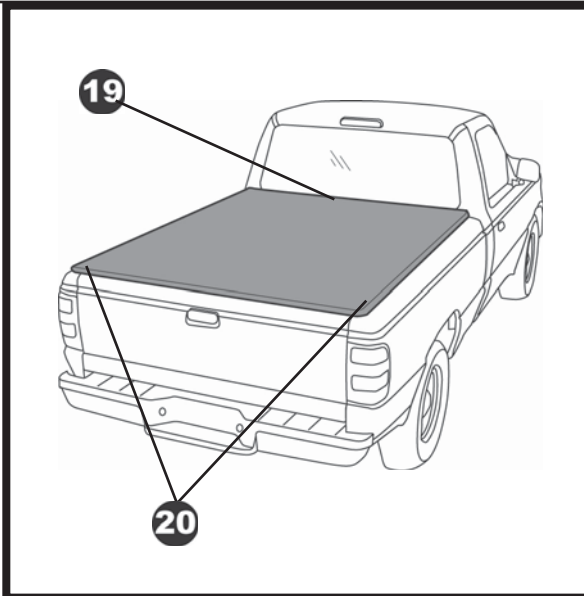
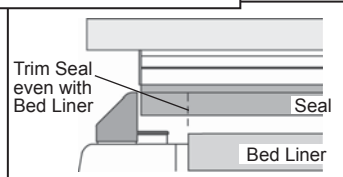
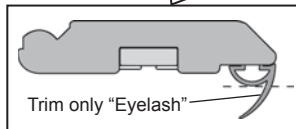
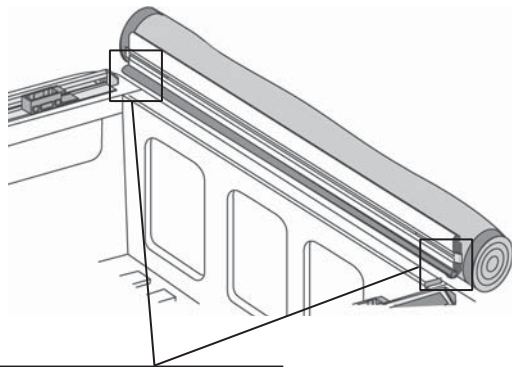

20 Special Instructions – Tailgate Caps

If your vehicle is equipped with a Tailgate Cap, you will need to trim the seal on the Tonneau Cover Assembly. Mark the seal at each end of the of the Tailgate Cap and use scissors to trim the bottom part of the seal at the mark.

NOTE Only trim the bottom part of the seal.

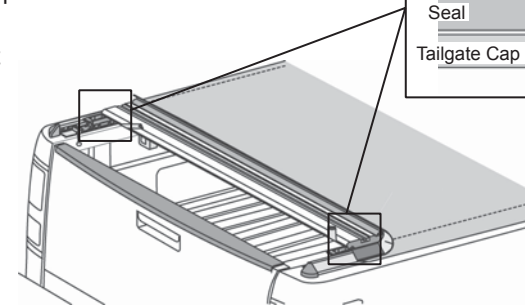
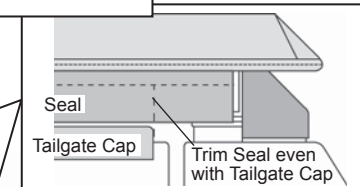
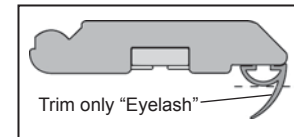



Care and Maintenance of your Bestop Product

Your Bestop product is made of the finest materials available. To keep it looking new and for the maximum possible wear, it will need periodic cleaning and maintenance.

Fabric: The fabric should be washed often using soap, warm water and a soft bristle brush. Rinse with clear water to remove all traces of soap. Bestop recommends using Bestop Cleaner (part no. 11201-00) and Bestop Protectant (part no. 11202-00) for Vinyl fabric and Bestop Twill Protectant (part no. 11207-00) for Twill fabric. Bestop Cleaner and Bestop protectant are specially formulated to provide a total cleaning and protection system. Bestop Cleaner safely removes the toughest stains, will not harm vehicle finishes, is biodegradable and environmentally friendly. Bestop Protectant protects against UV-fading, cracking and hardening, and repels dust, grease, dirt and mildew.

Windows: Keep windows clean to avoid scratching. **DO NOT** use a brush on the windows! Wash with a water-soaked cloth or sponge and a mild dishwashing detergent. Bestop recommends Bestop Vinyl Window Cleaner (part no. 11203-00), which safely cleans and protects vinyl windows and helps prevent UV damage. **NEVER WIPE THE WINDOWS WHEN THEY ARE DRY.** Be careful when cleaning snow or frost from the vinyl windows since they are easily scratched and may crack at low temperatures. **DO NOT** roll the sides or rear window in cold weather. The windows become stiff and will crack. Cracks caused by misuse in cold temperatures are not covered under warranty.

Water: Seeping through at the seams may be stopped by applying 3-M Scotchgard® on the inside of the seams.

Snaps: Keep snaps cleaned and lubricated with silicone to help prevent snaps from sticking to the studs. If a snap does become stuck to a stud, use a screwdriver and **GENTLY** pry apart to prevent permanent damage to the snap or the top fabric.

Zippers: Keeping zippers cleaned and lubricated with Bestop's Zipper Cleaner (part no. 11206-00) will help prevent damage and keep the zippers in smooth working condition. If a zipper opens behind the slider, the slider may have been spread apart. This problem can usually be repaired by using an ordinary pair of pliers to bring the sides back into parallel. Return slider to the end of the zipper in the normal Open position. Squeeze lightly at first and test the zipper. If the zipper continues to remain open squeeze more firmly with the pliers and try the zipper again. Repeat this procedure until the zipper operates correctly.

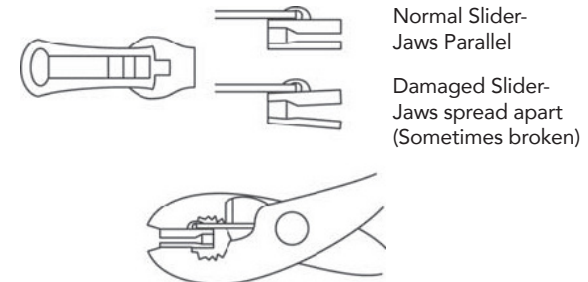

For Bestop Warranty Information, Please go to;
<https://www.bestop.com/help/warranty-information/>

