









# Installation Instructions

## HOSS™ Hardtop Organized Storage System

### Application:

- JK/JKU AND JL/JLU Jeep Wrangler, Wrangler Unlimited 2 and 4 Door Hard Top and Doors Storage System  
Part Number: 42805

[www.Bestop.com](http://www.Bestop.com) - We're here to help! Visit our web site and click on "[Ask a Question](#)". Click here for more [Jeep Accessories by Bestop](#).

INSTALLATION TIME	SKILL LEVEL		
 <b>2 Hours</b>	 <b>2 - Moderately Easy</b>		
TOOLS			
 Wrench 7/16", 3/4" and 9/16"	 Tape Measure	 Phillips Screwdriver	 Safety Glasses

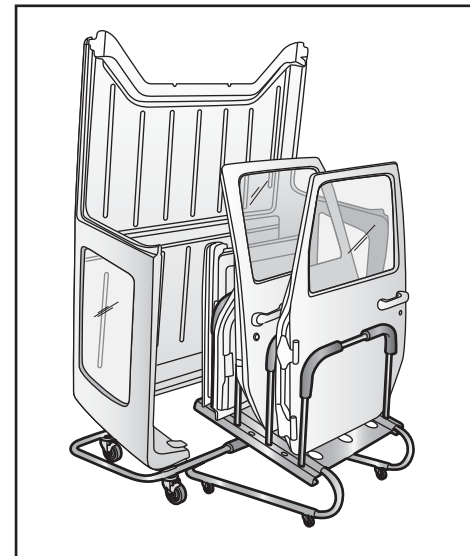

# HOSS™ Top Cart Installation Instructions

## Parts List and Hardware Identification

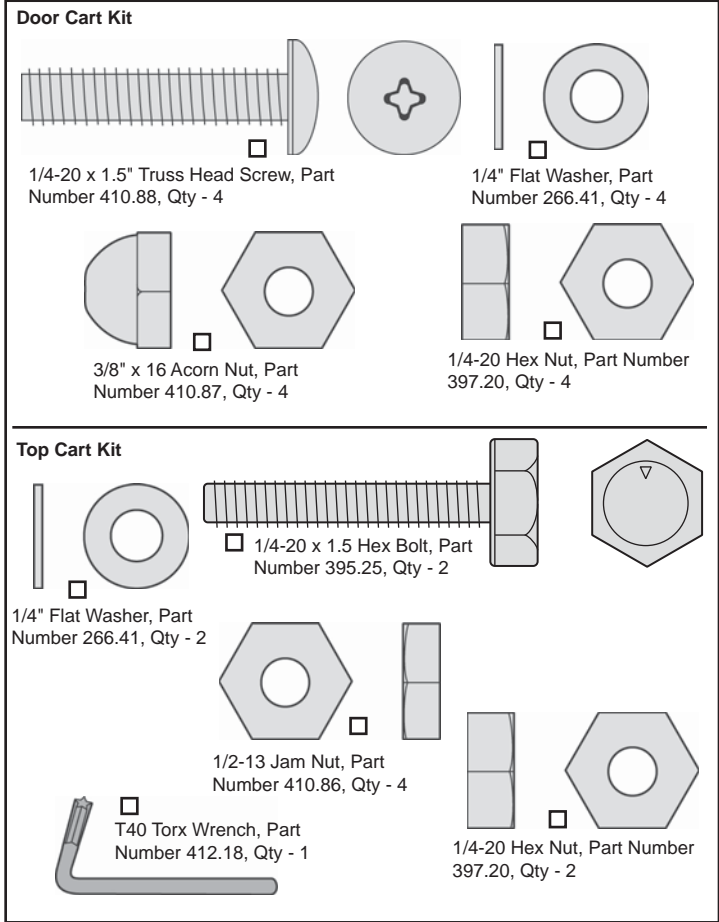
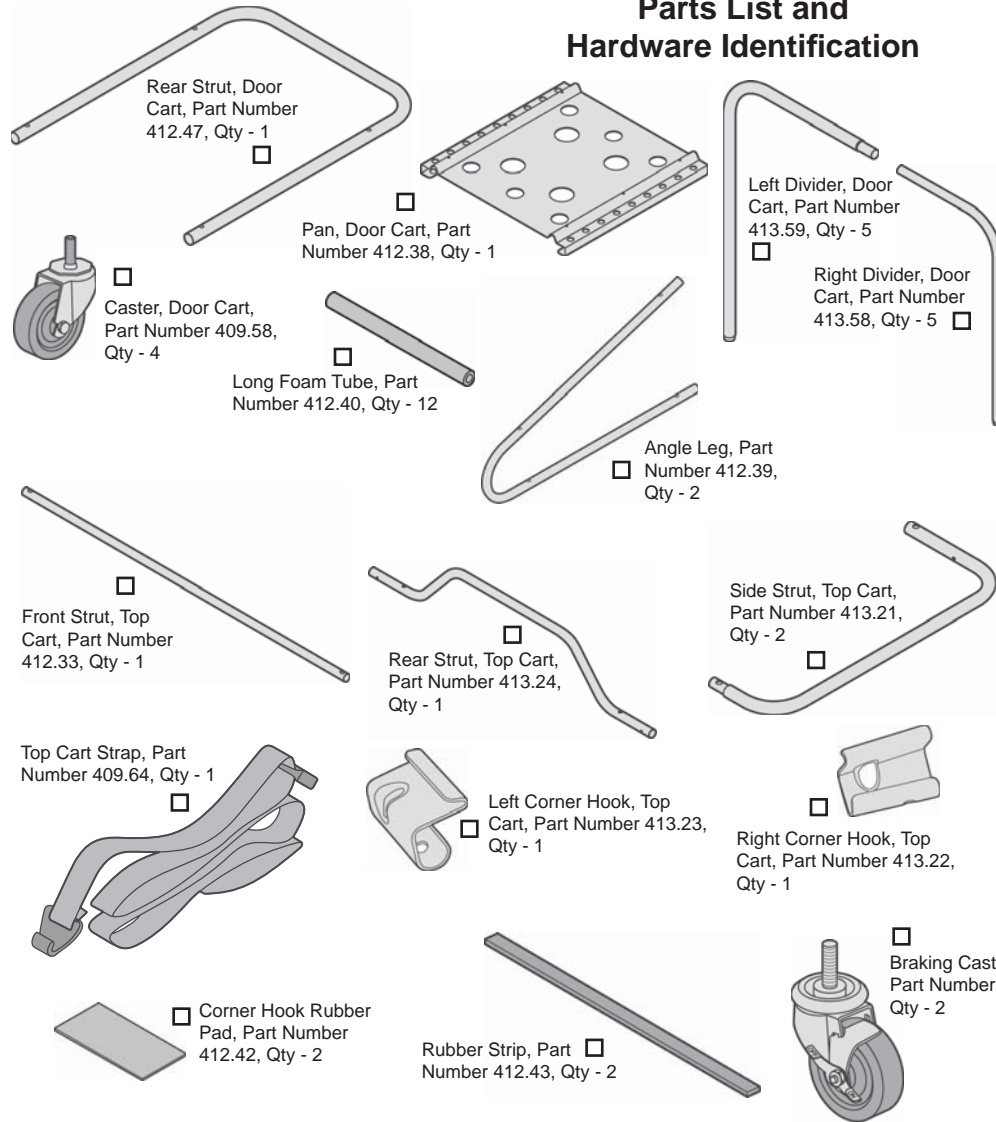

# HOSS™ Top Cart Installation Instructions

## 1 Install Long Foam Tubes on Front Strut - Top Cart

Locate the Top Cart Front Strut and two (2) of the Long Foam Tubes in the parts kit. Slide the sleeves over the strut and center them with a 2" space between them.

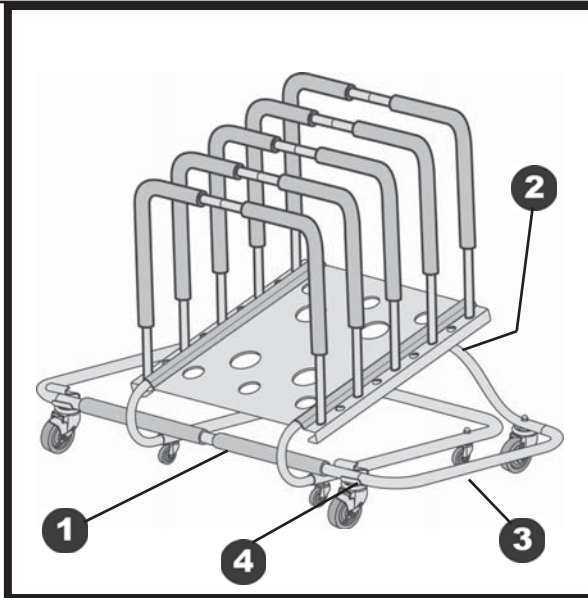
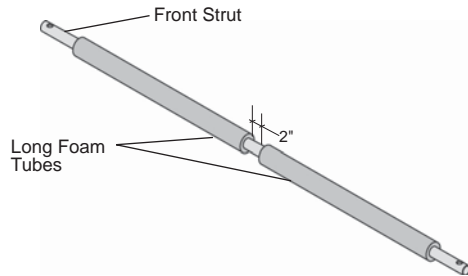

## 2 Install Short Foam Tubes on Rear Strut - Top Cart

Locate the Top Cart Rear Strut and the two Short Foam Tubes in the parts kit. Slide the sleeves onto the strut and center them with a 2" space between them.

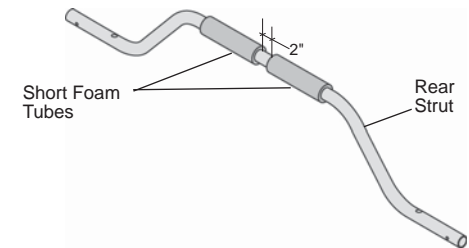

## 3 Assemble Top Cart Struts

Orient the Front, Rear and Side Struts to each other. Slide them together and line up all the holes.

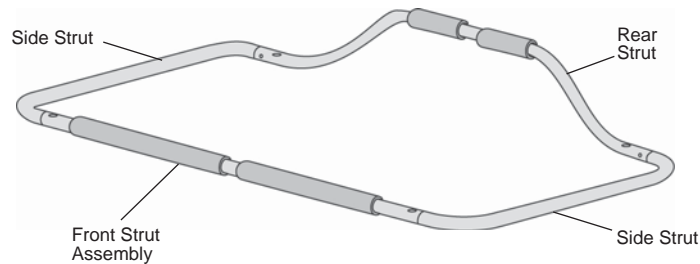

### 2007 – 2010 Models

## 4 Secure Front and Right Side Strut - Top Cart

Slide the Right Corner Hook onto the Front Strut. Place a 1/2-13 Jam Nut over the hole in the Front Strut. Install a Top Cart Braking Caster through both struts, the hook and into the Jam Nut.

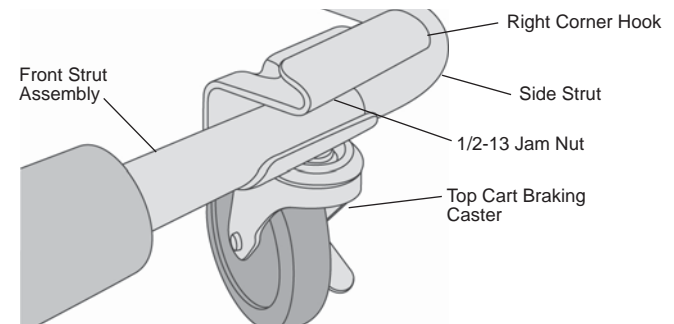

# HOSS™ Top Cart Installation Instructions

**2011 – 2018 JK/JKU and 2018-current JL/JLU Current Models**

## 4 Secure Front and Right Side Strut - Top Cart

Slide the Left Corner Hook onto the Front Strut. Place a 1/2-13 Jam Nut over the hole in the Front Strut. Install a Top Cart Braking Caster through both struts, the hook and into the Jam Nut.

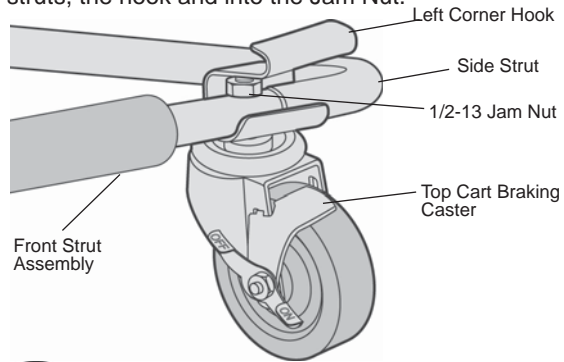

## 5 Secure Rear Strut to Top Cart Assembly

Place a Top Cart Caster without a brake through the larger holes where the Side and Rear Struts join and secure it with a 1/2-13 Jam Nut. Then install a 1/4-20 x 1.5" Hex Bolt, a 1/4" Washer and a 1/4-20 Hex Nut.

Repeat this procedure with the other Side Strut / Rear Strut Assembly.

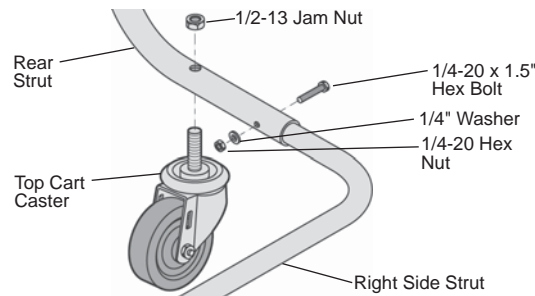
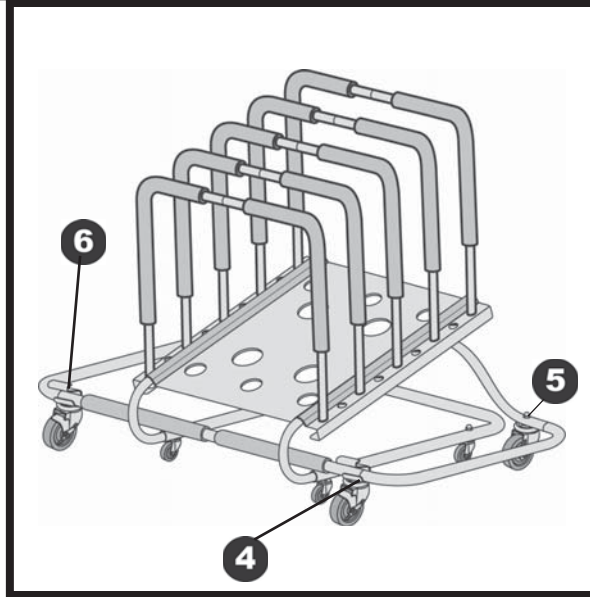

**2007 – 2010 JK/JKU Models**

## 6 Install Left Front Braking Caster and Corner Hook - Top Cart

Slide the Left Corner Hook onto the Front Strut. Slide the end of the Left Side Strut into the end of the Front Strut Assembly. Place a 1/2-13 Jam Nut over the hole in the Front Strut. Install a Top Cart Braking Caster through both struts, the hook and into the Jam Nut. Securely tighten all hardware.

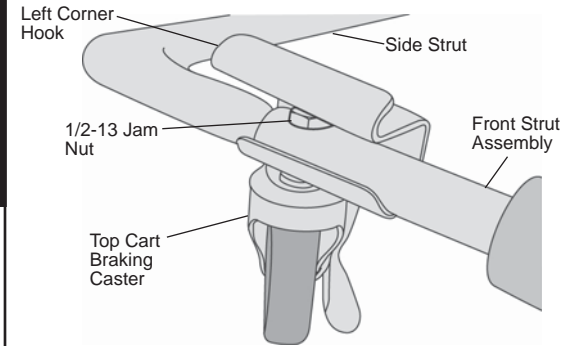

# HOSS™ Top Cart Installation Instructions

2011 – 2018 JK/JKU and  
2018-current JL/JLU Current Models

## 6 Install Right Front Braking Caster and Corner Hook - Top Cart

Slide the Right Corner Hook onto the Front Strut. Slide the end of the Left Side Strut into the end of the Front Strut Assembly. Place a 1/2-13 Jam Nut over the hole in the Front Strut. Install a Top Cart Braking Caster through both struts, the hook and into the Jam Nut. Securely tighten all hardware.

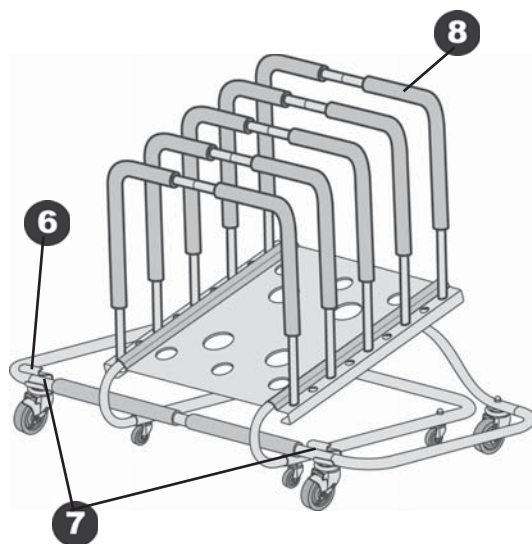
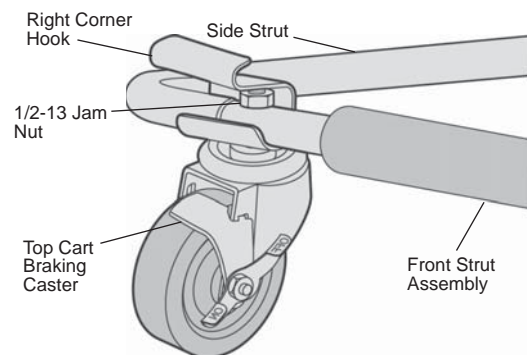

## 7 Install Corner Hook Rubber Pads - Top Cart

Locate the Corner Hook Rubber Pads in the parts kit. Clean the flat area on the Corner Hooks. Orient the Corner Hook Rubber Pads to fit squarely on the Corner Hooks. Remove the backing from the pads and press them firmly onto the Corner Hooks.

## 8 Assemble Dividers - Door Cart

Slide a Long Foam Tube over one half of each pair of Dividers. Slide the sleeve up and around the bend. Press the Divider halves together. Assemble five (5) Dividers.

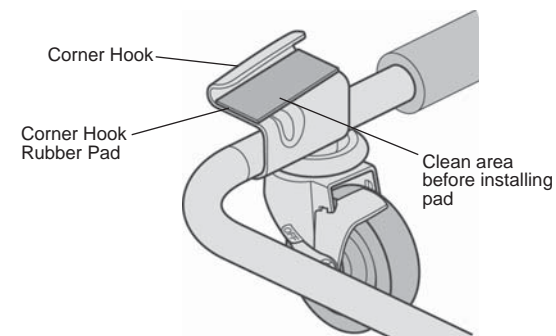
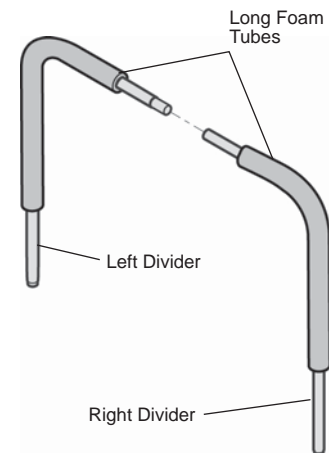

# HOSS™ Top Cart Installation Instructions

## 9 Install Angle Legs and Casters on Door Cart Rear Strut

Locate the Angle Legs and Rear Strut in the parts kit. Slide the Angle Legs into the ends of the Rear Strut and align the holes. Install a Door Cart Caster in each set of holes with a 3/8-16 Acorn Nut. Do not tighten the nuts at this time.

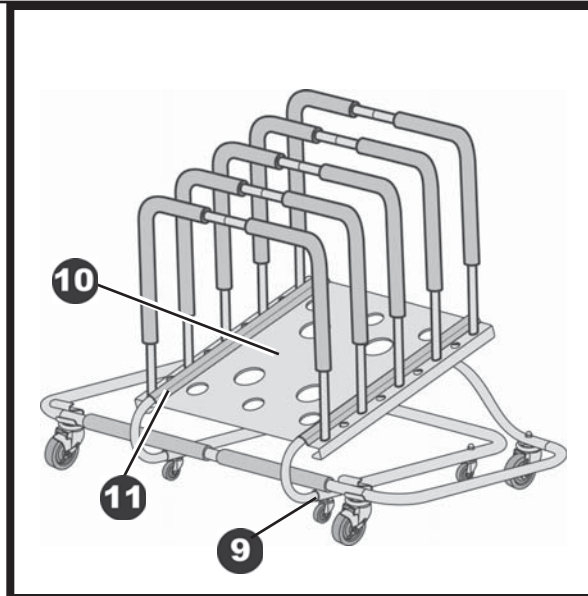
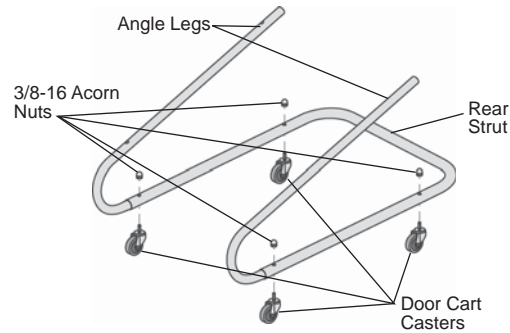

## 10 Install Door Cart Pan

Orient the Door Cart Pan on the Door Cart Assembly so the holes in the lower ledge along the side of the pan are toward the bottom of the pan in relation to the holes in the top layer. Align the mounting holes in the pan with the mounting holes on the Angle Legs and install a 1/4-20 x 1.5 Truss Head Screw, 1/4" Washer and 1/4-20 Hex Nut in each hole.

Tighten the Truss Head Screws then tighten the Acorn Nuts that secure the Casters to the Door Cart.

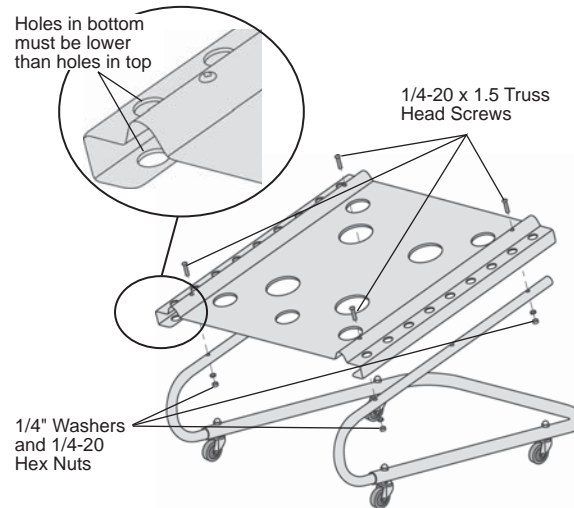

## 11 Install Rubber Strips

Orient the Rubber Strips along the top of the mounting ridges, over the heads of the Truss Head Screws. Center the strips from top to bottom on the pan. Peel the backing off the strips a little at a time and press them firmly into place.

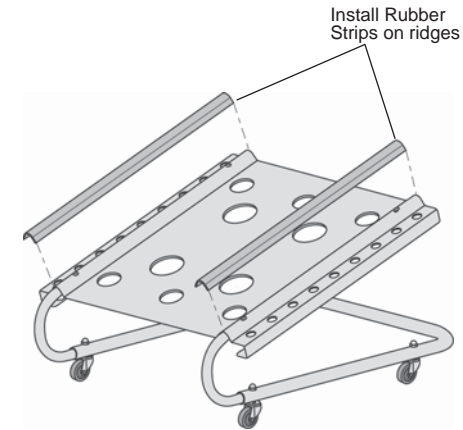

# HOSS™ Top Cart Installation Instructions

**! WARNING** The maximum load for the Door Cart is 235 lbs.

## 12 Install Dividers in Door Cart

Insert the Dividers into the holes along the sides of the Cart Pan. The ends of the Dividers should fit securely into the mounting holes.

**NOTE** Store taller doors toward the back of the Door Cart with shorter doors toward the front.

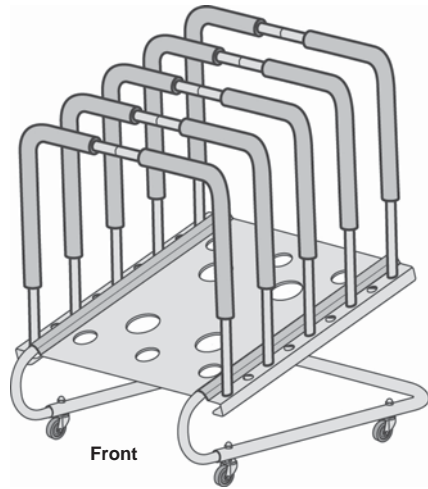

## 13 Removing your OEM Hardtop

Release the latches that secure the SunTops to the windshield. Release the knobs that secure the SunTops to the rear deck. Release the Levers. Remove the SunPanels from the vehicle.

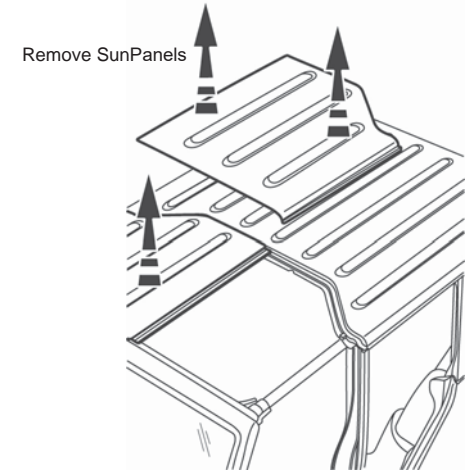
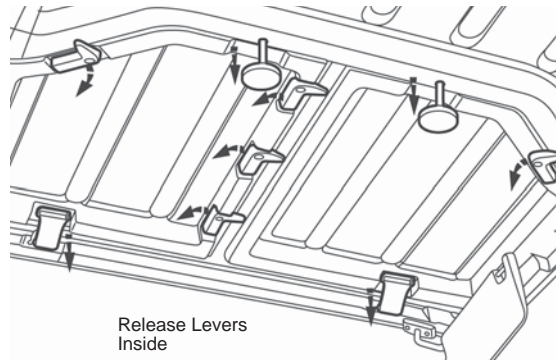

# HOSS™ Top Cart Installation Instructions

## 14 Removing your Hardtop

Use the T40 Torx Wrench to remove the six (6) Torx Bolts that secure the 2 Door Hardtop or the eight (8) Torx Bolts that secure the 4 Door Hardtop.

Carefully store the bolts to be used when reinstalling the top.

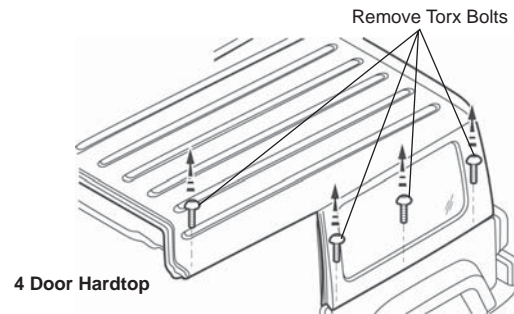
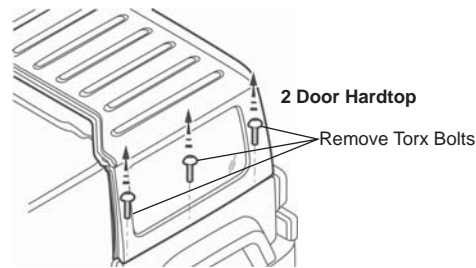

## 15 Install Strap on Top Cart

Orient the Top Cart Strap with the buckle facing the rear of the Top Cart. Wrap the straight end of the strap around the Rear Strut in the space between the two Foam sleeves. Pull it toward the buckle in the middle of the strap without twisting.

Thread the end of the strap through the buckle.

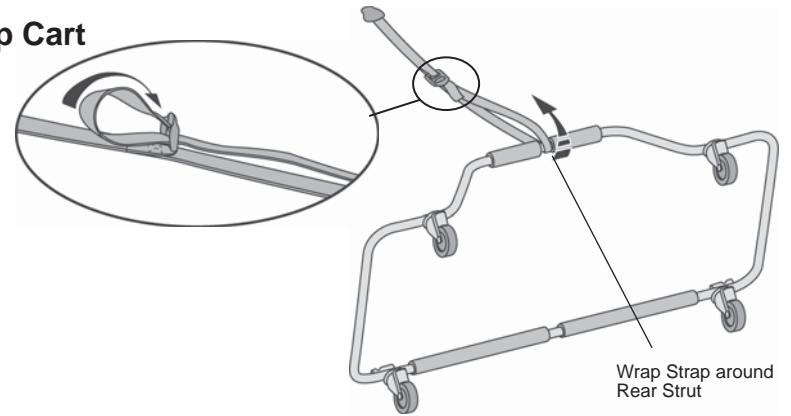

### CAUTION

Four or more people are required to lift the hardtop safely.

## 16 Removing your Hardtop

Orient the Top Cart Strap with the buckle in the middle of the strap facing up. Thread the straight end of the strap between the hard top and the Rear Strut in the space between the two Foam Sleeves.

If you have a one piece top, take the hook end of the strap up and hook it to the front edge of the top.

If you have a two piece top, wrap the strap around the front edge and back to hook it to the upper inside lip of the rear window.

Do not twist the strap.

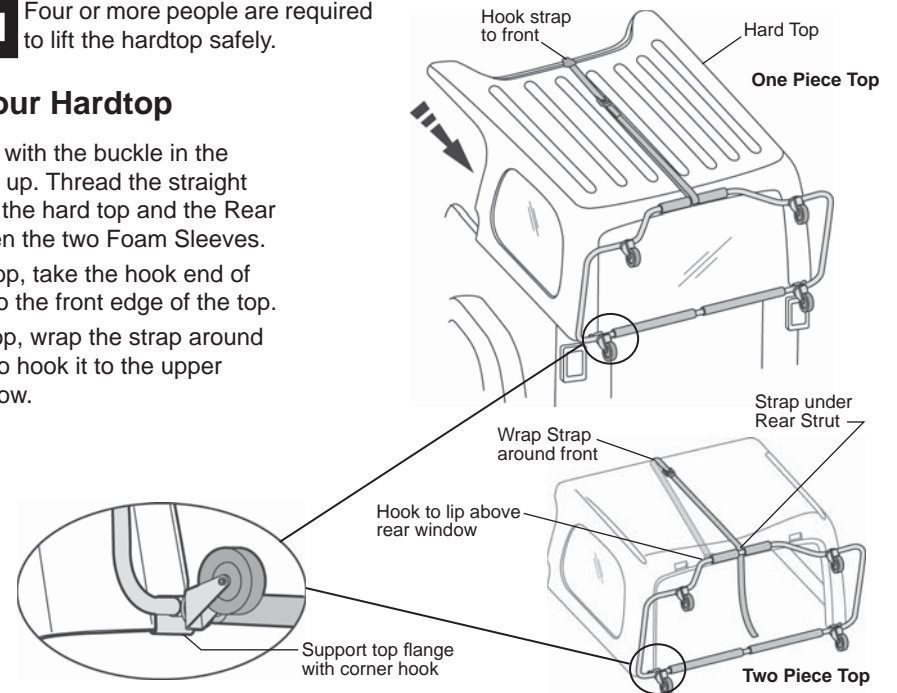



## HOSS™ Top Cart Installation Instructions

---



### CAUTION

Four or more people are required to lift the hardtop safely.

### 17 Removing your Hardtop

Use the Side Struts as handles to lift the hardtop and Top Cart off the vehicle and move toward the rear. Slowly place the top in its normal position down on the ground next to the vehicle. Recheck that the strap is secure.

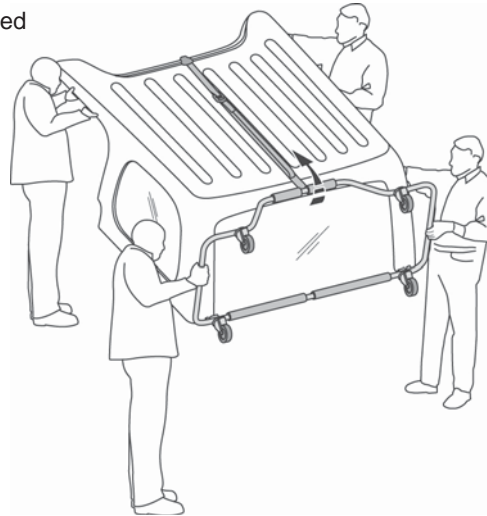

### CAUTION

Two or more people are required to lift the hardtop safely.

DO NOT allow the hardtop to rock backwards while lifting.

### 18 Removing your Hardtop

Lock the Front Brake Casters. Slowly lift the front of the hardtop until it is completely resting on the Top Cart Casters. Do not allow the hardtop to rock backwards as it approaches the full upright position.

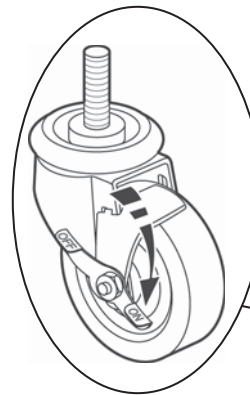

Lock Front Brake Casters

## HOSS™ Top Cart Installation Instructions

---

### 19 Storing your Hardtop

Release the Front Brake Casters and roll the hardtop/ cart assembly into position for storage. Once the cart is in this position, again lock the front casters.

Roll door cart into top cart and load with doors. Center the cart in the top.





# BESTOP WARRANTY SUMMARY

Updated July 2017



## WHAT BESTOP WARRANTS

Subject to the terms and conditions of sale, including any terms and conditions set forth by Bestop, Inc. ("Bestop" or "us" or "we") in our then-current terms of sale on our website (collectively, the "Terms"), Bestop represents and warrants that: the covered products listed in the "Covered Products and Warranty Periods" section (a "Product") will substantially be free from defects in materials and workmanship for the specified warranty periods set forth in that section.

## THE WARRANTY IS LIMITED AND CONDITIONAL

This warranty applies to the original purchaser of the Product only. The warranty is valid only as long as the original retail purchaser owns the vehicle upon which the Product is installed. The warranty expires should the Product be removed from the original vehicle or if the original vehicle is transferred to another owner. This warranty is not transferable or assignable. The warranty does not apply to Product bought from auction-style or price-bid websites.

THE LIMITED WARRANTY AND STATED REMEDIES ARE SOLE AND EXCLUSIVE AND IN LIEU OF ALL OTHER WARRANTIES AND REMEDIES, AND COMPANY EXPRESSLY DISCLAIMS ALL IMPLIED OR STATUTORY OR OTHER WARRANTIES, INCLUDING WITHOUT LIMITATIONS WARRANTIES OF MERCHANTABILITY, NON-INFRINGEMENT, OR FITNESS FOR A PARTICULAR PURPOSE. IN NO EVENT WILL COMPANY BE LIABLE FOR ANY SPECIAL, INCIDENTAL, CONSEQUENTIAL, PUNITIVE, INDIRECT OR EXEMPLARY DAMAGES OF ANY KIND, INCLUDING LOST PROFITS OR REVENUE, HOWEVER CAUSED, WHETHER FOR BREACH OR REPUDIATION OF CONTRACT, TORT, BREACH OF WARRANTY, NEGLIGENCE, OR OTHERWISE, WHETHER OR NOT COMPANY WAS ADVISED OF THE POSSIBILITY OF SUCH LOSS OR DAMAGES. *Some states do not allow exclusion or limitation, so this may not apply to you. This warranty gives you specific legal rights, and you may have other rights which vary from state to state.*

## EXCLUSIONS TO THE WARRANTY

The Limited Warranty excludes, and Bestop is not liable in any way for any warranty claims, damages, or defects related to:

- Misuse, abuse, accidents, vandalism, negligence, fire, or improper installation or modification, or improper or inadequate maintenance;
- Failure to comply with any Product documentation, Bestop instructions, or applicable law or regulations; use in extreme conditions
- Force Majeure including but not limited to, earthquake, hurricane, tornado, flooding, or other disasters natural or man-made, civil unrest, strikes, declared or undeclared war, or lack of performance by, or discontinued product of, supply chain partners whose products, software, operations or management is beyond the control of Bestop;
- Damage resulting in breakage (including without limitation, spontaneous breakage, accidental breakage or breakage by any other means) of a Product or any component part;
- Damage to vinyl windows due to misuse, or cracking due to varying weather conditions.

## YOUR SOLE REMEDY

During the applicable warranty period, Bestop shall, at its option, either repair or replace any Product that it confirms, in its discretion, is non-compliant with the warranties herein. Bestop will not pay for labor charges associated with installation or removal of the Product. Should a specific Product be discontinued, Bestop may, at its option, replace the discontinued Product with a current product or like product. If Bestop opts to repair or replace your Product as set forth herein, Bestop shall use reasonable efforts to match any patch or replacement to the color and texture of your existing Product. There is no guarantee however, that Bestop will be able to match the color or texture. If Bestop is not able to match the color or texture, it may provide you with a black or neutral colored patch replacement in its discretion.

Please retain your proof of purchase. Original proof of purchase for the Product must accompany any warranty claim. If you have a warranty claim, first you must email Bestop Customer Service at [csbestop@bestop.com](mailto:csbestop@bestop.com) for instructions. All claims must be emailed to [csbestop@bestop.com](mailto:csbestop@bestop.com) within 30 days of discovery of a defective Product, but in no event later than thirty days after the end of the applicable Warranty Period (the "Warranty Notice Period"). Warranty claims made after the Warranty Notice Period are null and void and Bestop shall have no responsibility with respect to such claims.

THIS SECTION SETS FORTH BESTOP'S SOLE OBLIGATION & YOUR SOLE REMEDY WITH RESPECT TO ANY DEFECTS OR OTHER PRODUCT ISSUE. ANY PRODUCTS REPLACED UNDER TERMS OF THIS WARRANTY WILL BE COVERED UNDER TERMS & BALANCE OF THE DURATION OF THE ORIGINAL LIMITED WARRANTY FOR SUCH PRODUCT.

**COVERED PRODUCTS AND WARRANTY PERIODS:** The warranty time periods are as follows for Products manufactured by Bestop:

### BESTOP® LIMITED LIFETIME WARRANTY

Trektop® Pro Twill Fabric Top	Sunrider® for Hardtop Twill Fabric Top
Trektop® NX Glide Twill Fabric Top	Replace-a-Top™ Twill Fabric Top
Trektop® NX Twill Fabric Top	Supertop® NX Twill Fabric Top
EZFold™ Soft Tonneau	Floor & Cargo Liners
ZipRail™ Soft Tonneau	Pet Barriers
EZRoll™ Soft Tonneau	

### BESTOP® 5-YEAR LIMITED WARRANTY

Trektop® NX Glide™ Top (non-Twill)	Sunrider® for Hardtop (non-Twill)
Replace-a-Top™ Top (non-Twill)	Trektop® NX Top (non-Twill)
Sailcloth Replace-a-Top™	Supertop® NX Top (non-Twill)
TigerTop™ and HalfTop™	Supertop® Classic Soft Top
Sunrider® Complete Soft Top	Supertop® for Truck
EZ Fold Hard Tonneau	

### BESTOP® 3-YEAR/100K MILES LIMITED WARRANTY

Powerboard® & Powerboard® NX
Trekstep®, Side Mount
Trekstep®, Rear Mount

### BESTOP® 3-YEAR LIMITED WARRANTY

Pavement Ends Sprint Top
--------------------------

### BESTOP® 2-YEAR LIMITED WARRANTY

Trektop® Classic Soft Top
RoughRider™ Soft Storage

### BESTOP® 1-YEAR LIMITED WARRANTY

All other Bestop® & Pavement Ends™ products not specified above.
------------------------------------------------------------------