



# Installation Instructions

## HighRock 4x4™ Rear Bumper

Vehicle Application: 2007 - Current Jeep® Wrangler and Wrangler Unlimited

•HighRock 4x4™ Rear Bumper

Part Number: 42911 / 44911

•HighRock 4x4™ Departure Roller™

Part Number: 42905 (Sold Separately)

[www.Bestop.com](http://www.Bestop.com) - We're here to help! Visit our web site and click on "[Ask a Question](#)". Click here for more [Jeep® Accessories by Bestop](#).

INSTALLATION TIME	SKILL LEVEL		
 1-1/2 Hours	 3 - Moderately Difficult		
TOOLS			
 Socket 18mm and 5/8"	 Ratchet	 Hammer	 Wrench 18mm and 5/8"
 Safety Glasses			



### **! WARNING**

This product is designed primarily to enhance the appearance of the vehicle. Do not rely in any way on the components of this product to protect against injury or death in the event of an accident. Never operate the vehicle in excess of manufacturer's specifications.

### **WEAR SEAT BELTS AT ALL TIMES**

Read and follow, precisely, all installation instructions provided when installing product. Failure to do so may result in a poor fit and could place occupants of the vehicle in a potentially dangerous situation.

# HighRock 4x4™ Rear Bumper Installation Instructions

## Parts List and Hardware Identification

Rear Bumper,  
Part Number 498.34 (Gloss Finish),  
Part Number 498.23 (Matte Finish),   
Qty - 1

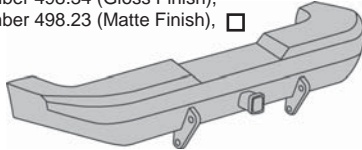

### 42905 HighRock 4x4™ Departure Roller™ – Sold Separately

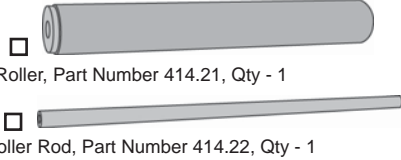

Roller, Part Number 414.21, Qty - 1

Roller Rod, Part Number 414.22, Qty - 1

### Hardware Kit Part # 498.37

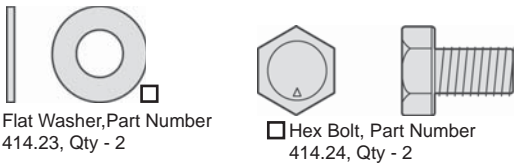

Flat Washer, Part Number 414.23, Qty - 2

Hex Bolt, Part Number 414.24, Qty - 2

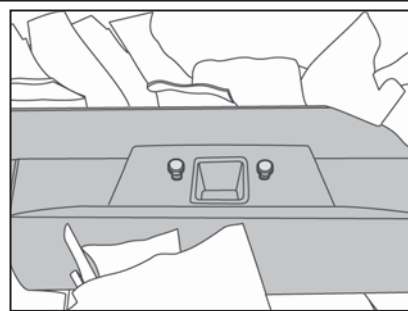

### Hardware Kit Part # 485.74

M12 Hex Bolt Part # 485.43 Qty 2  
M12 Lock Washer Part # 485.45 Qty 2  
M12 Flat Washer Part # 485.44 Qty 2

Already installed on the HighRock 4x4™ Rear Bumper.

Remove the foam packaging to access these

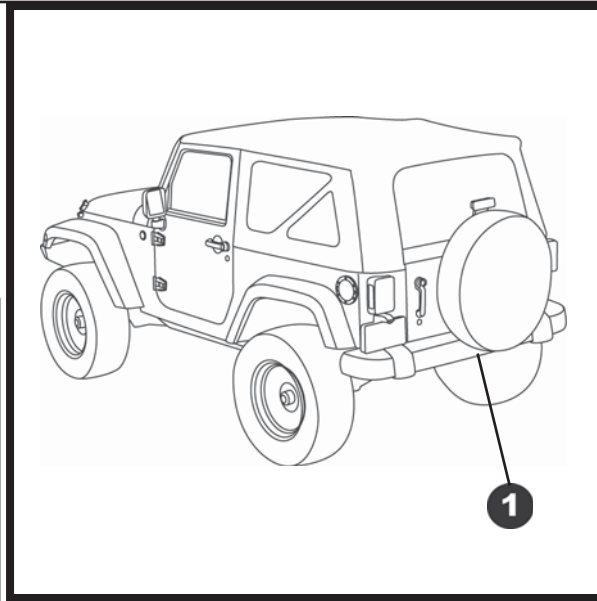

## 1 Remove Tow Hitch or Tow Hook

If you do not have a tow hitch or tow hook, proceed to Step 2.

If your vehicle is equipped with a tow hitch or tow hook, you will need to remove it before you remove the factory bumper.

**To remove a tow hitch**, use a wrench with an 18mm socket to remove the four (4) bolts that secure it to the bumper and discard them.

**If you have a tow hook**, use a wrench with an 18mm socket to remove the three (3) bolts that mount it to the bumper and discard them.

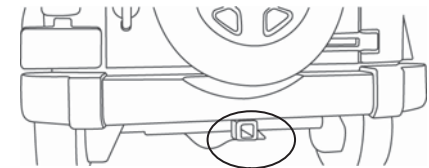

Remove 4 Bolts that Mount Tow Hitch

Remove 3 Bolts that Mount Tow Hook

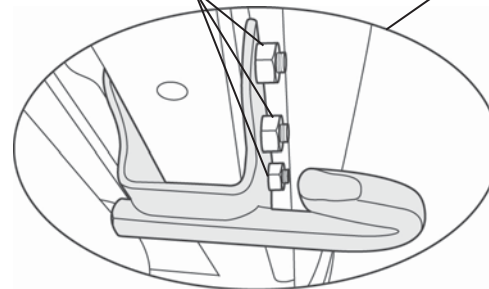

View from under bumper

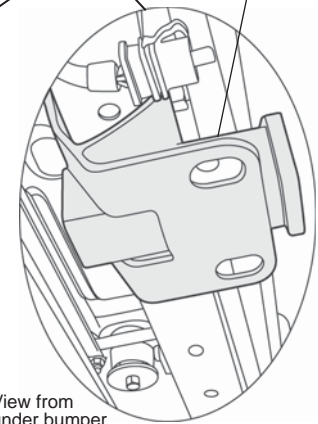

View from under bumper

## HighRock 4x4™ Rear Bumper Installation Instructions

### 2 Remove Bolts on end of Factory Bumper

Use a socket wrench and 5/8" socket to remove the two (2) bolts on each side of the bumper that attach it to the frame. Set the bolts aside to be re-used to install the HighRock 4x4™ Bumper.

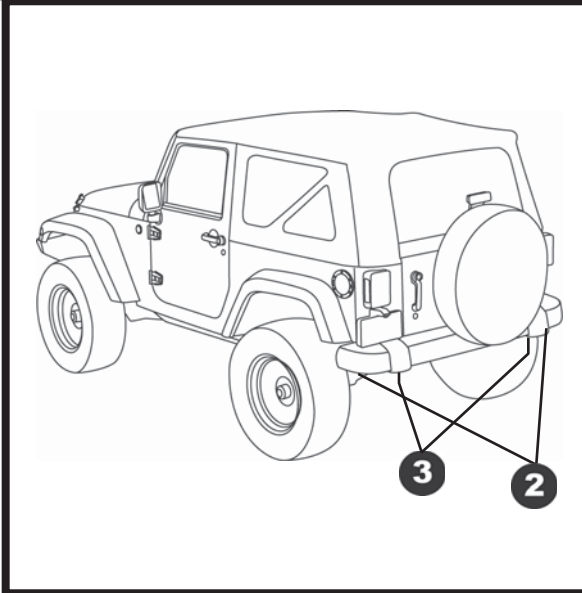
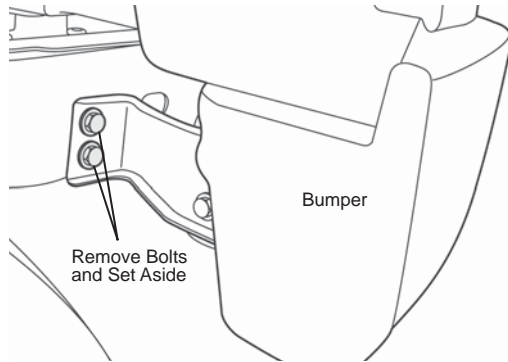

### CAUTION

Two or more people may be required to lift the bumper safely.

### 4 Remove Factory Bumper

Position a person on each end of the bumper to lift it away from the vehicle. Set the bumper aside.

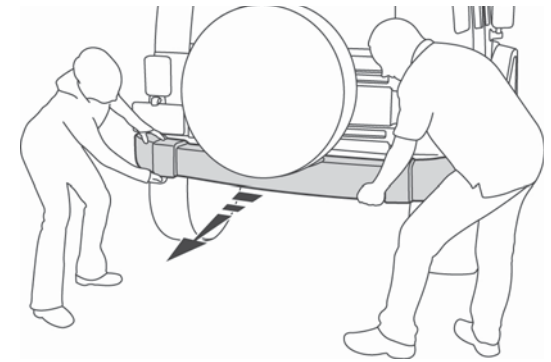

### 3 Remove Bracket Bolts on Original Bumper

Use a socket wrench and 5/8" socket to remove the bolts that secure the brackets on each side of the bumper. Discard the brackets.

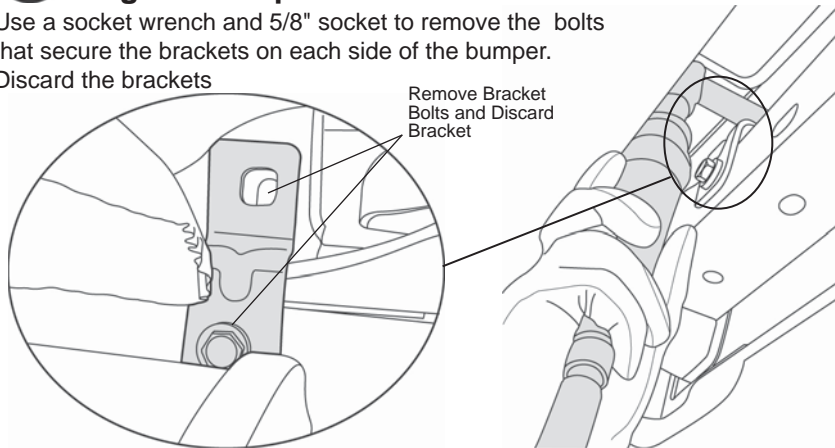

### CAUTION

Two or more people may be required to lift the bumper safely.

### 5 Install HighRock 4x4™ Bumper

Position a person on each end of the HighRock 4x4™ Bumper to lift it onto the vehicle.

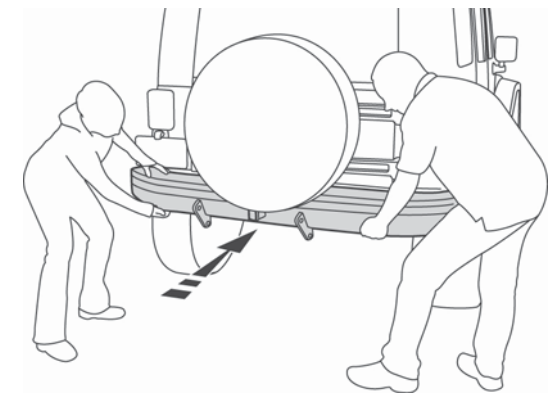

# HighRock 4x4™ Rear Bumper Installation Instructions

## 6 Install Center Bolts

Locate the two (2) factory installed Hex Bolts on each side of the hitch. Install Washers and Lock Washers on them.

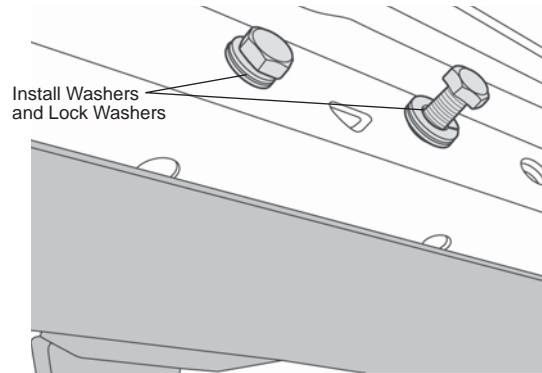

View from under bumper

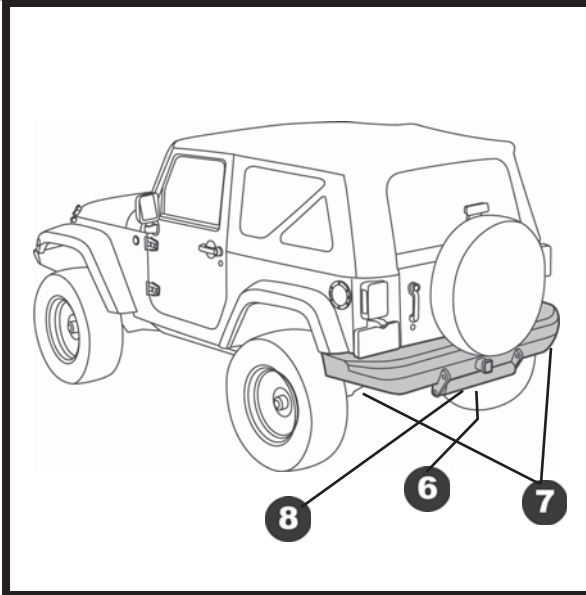

## 8 Install 42905 HighRock 4x4™ Departure Roller™ – Sold Separately

Place the Roller between the flanges on the Rear Bumper and align the holes in the Roller with the holes in the flange. Slide the Rod through the flanges and the Roller. Install a Hex Bolt and a Washer in each end of the Rod to secure it to the flanges.

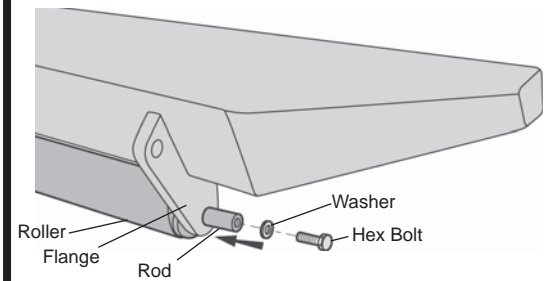

## 7 Re-Install Side Frame Bolts

Use the bolts that were removed in Step 2 to secure each end of the HighRock 4x4™ Bumper.

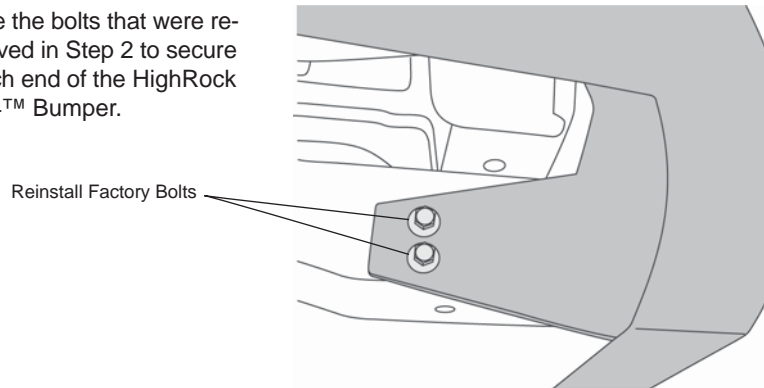

### **WARNING** Tow Rating Warning

Do not exceed the vehicle manufacturer's recommended towing capacity.

### **WARNING** DO NOT cut, drill, weld or modify the Bumper.

# HighRock 4x4™ Rear Bumper Installation Instructions

---

## LIMITED WARRANTY

We warrant our product to be free from defects in material and workmanship, for the terms specified below, provided there has been normal use and proper maintenance. This warranty applies to the original purchaser only. All remedies under this warranty are limited to the repair or replacement of any item or items found by the factory to be defective within the time period specified. If you have a warranty claim, first you must call our factory at the number below for instructions. You must retain proof of purchase and submit a copy with any items returned for warranty work. Upon completion of warranty work, if any, we will return the repaired or replaced item or items to you freight prepaid. Damage to our products caused by accidents, fire, vandalism, negligence, misinstallation, misuse, Acts of God, or by defective parts not manufactured by us, is not covered under this warranty.

THE WARRANTY TIME PERIOD IS AS FOLLOWS FOR REPLACE-A-TOP™, SAILCLOTH REPLACE-A-TOP™, SUPERTOP®, SUPERTOP® REPLACEMENT SKINS, SUNRIDER®, AND TIGERTOP®: TWO YEARS FROM DATE OF PURCHASE.

THE WARRANTY TIME PERIOD IS AS FOLLOWS FOR ALL OTHER “SOFT GOODS” MANUFACTURED BY OUR COMPANY (USING PRIMARILY VINYL, PLASTICS, AND/OR FOAM): ONE YEAR FROM DATE OF PURCHASE.

THE WARRANTY TIME PERIOD IS AS FOLLOWS FOR ALL OTHER “HARD GOODS” MANUFACTURED BY OUR COMPANY (USING PRIMARILY METALS, PLASTICS, AND/OR FIBERGLASS): ONE YEAR FROM DATE OF PURCHASE.

ANY IMPLIED WARRANTIES OF MERCHANTABILITY AND/OR FITNESS FOR A PARTICULAR PURPOSE CREATED HEREBY ARE LIMITED IN DURATION TO THE SAME DURATION AND SCOPE AS THE EXPRESS WRITTEN WARRANTY. OUR COMPANY SHALL NOT BE LIABLE FOR ANY INCIDENTAL OR CONSEQUENTIAL DAMAGE.

Some states do not allow limitations on how long an implied warranty lasts, or the exclusion or limitation of incidental or consequential damages, so the above limitations or exclusions may not apply to you. This warranty gives you specific legal rights, and you may also have other rights which vary from state to state.



For further information or request for warranty work, please contact:  
Bestop Inc. Customer Service  
Toll-Free: (800)845-3567  
Main: (303)465-1755  
E-mail: [csbestop@Bestop.com](mailto:csbestop@Bestop.com)  
Website: [www.Bestop.com](http://www.Bestop.com)