



Installation Instructions Seat Slider with Adapter

for use with Trailmax and Trailmax II Seats



Vehicle Application:



•Jeep Wrangler and Wrangler Unlimited
2003 – 2006

Driver Side (Left)
Part Number: 51245

Passenger Side (Right)
Part Number: 51248

www.Bestop.com - We're here to help! Visit our web site and click on "[Ask a Question](#)". Click here for more [Jeep® Accessories by Bestop](#).

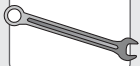
INSTALLATION TIME	SKILL LEVEL
 3/4 Hour	 2 - Moderately Easy

TOOLS		
 Wrench 13mm	 Torx Wrench T-50	 Safety Glasses

 **WARNING** Disconnect the battery before continuing with this installation.

 **CAUTION** Safety glasses should be worn at all times while installing this product.

 **WARNING** This product is designed primarily to enhance the appearance of the vehicle. Do not rely in any way on the components of this product to protect against injury or death in the event of an accident. Never operate the vehicle in excess of manufacturer's specifications.

WEAR SEAT BELTS AT ALL TIMES

Read and follow, precisely, all installation instructions provided when installing product. Failure to do so may result in a poor fit and could place occupants of the vehicle in a potentially dangerous situation.

Seat Slider with Adapter Installation Instructions

Parts List and Hardware Identification

Seat Slider with Adapter (51245 shown), Qty - 1



8mm Nut, Qty - 6



8mm Washer, Qty - 6

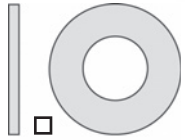

12mm Washer, Qty - 1

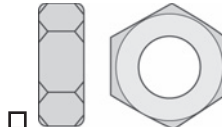

12mm Nut, Qty - 1

1 Remove Seat from Vehicle

Use a 13mm wrench to remove the front bolts securing the seat to the vehicle. Open the plastic shield over the rear bolts and use a T-50 Torx to remove them. Set the bolts aside to be reused.

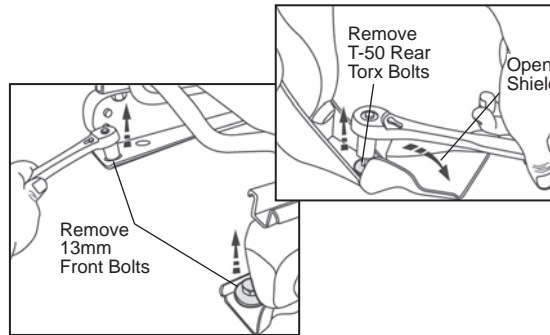

2 Unplug Seatbelt Sensor

Unplug the seatbelt sensor wire. Remove seat from vehicle.

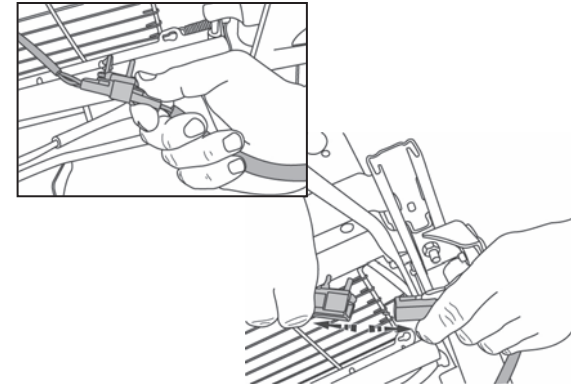

3 Release Fold and Tumble Cable

Unclip the fold and tumble cable from the O.E. Seat Riser.

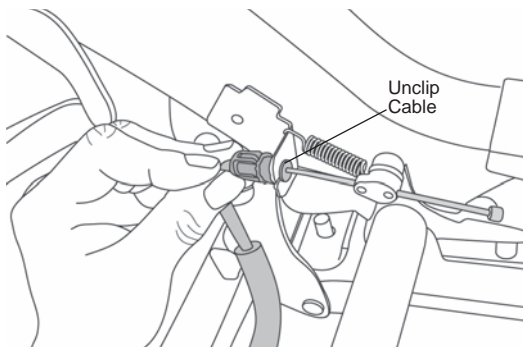

4 Remove Seatbelt Receiver

Use a T-50 Torx to remove the O.E. seatbelt receiver from the O.E. Seat. Save the bolt and washer to be reused later.

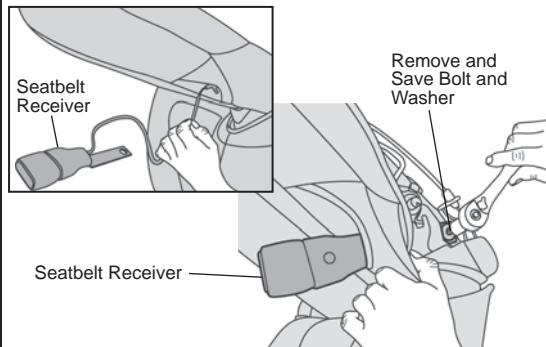

5 Remove the O.E. Seat and Slider from the Riser

Use a 13mm wrench to remove the O.E. Seat and Slider from the O.E. Seat Riser. Discard the six (6) nuts.

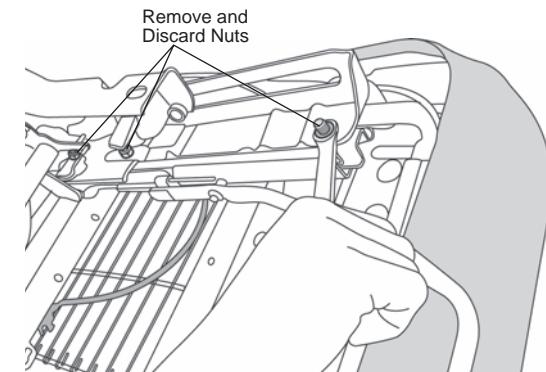

Seat Slider with Adapter Installation Instructions

6 Install Seat Slider on Trailmax™ Seat

Use the bolts that came with your Trailmax™ Seat to install the Slider on the seat.

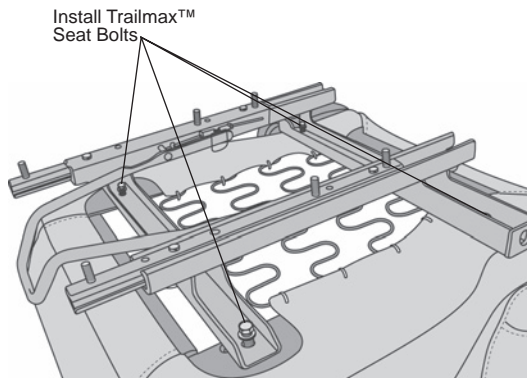

7 Reinstall the Seatbelt Receiver

Use the Torx bolt removed in Step 4 with a 12mm Washer and 12mm Nut to mount the Seatbelt Receiver to the Seat Slider with Adapter.

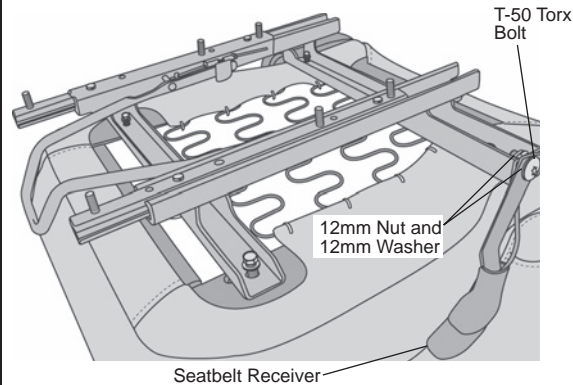

8 Clear Seatbelt Sensor Wire

Pull the seatbelt sensor wire through so it does not interfere with the seat installation.

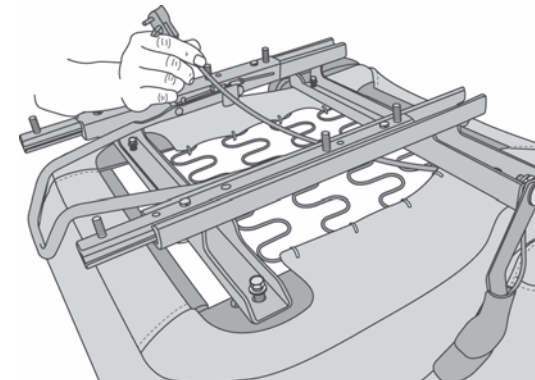

9 Install Seat and Slider Assembly to Seat Riser

Use the M8 Nuts and M8 Washers to mount the Trailmax™ Seat and Slider Assembly to the Seat Riser.

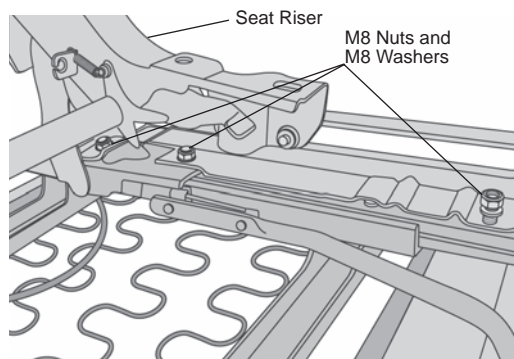

10 Reattach Seatbelt Sensor Wire

Place the seat back in the vehicle.
Plug in the seatbelt sensor wire.

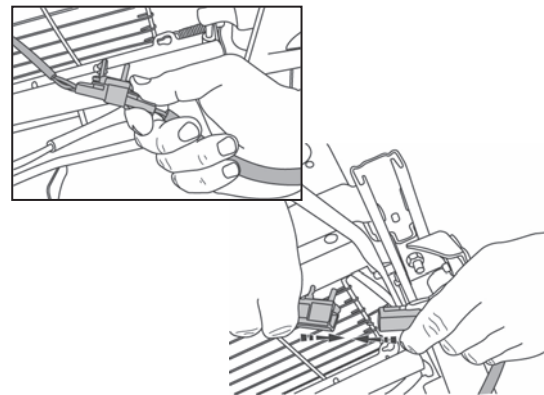

11 Reinstall Seat in Vehicle

Use a 13mm wrench to reinstall the front bolts securing the seat to the vehicle. Use a T-50 Torx to reinstall the rear bolts.

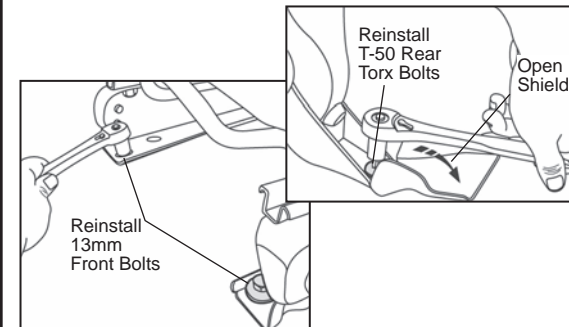

Seat Slider with Adapter Installation Instructions

LIMITED WARRANTY

We warrant our product to be free from defects in material and workmanship, for the terms specified below, provided there has been normal use and proper maintenance. This warranty applies to the original purchaser only. All remedies under this warranty are limited to the repair or replacement of any item or items found by the factory to be defective within the time period specified. If you have a warranty claim, first you must call our factory at the number below for instructions. You must retain proof of purchase and submit a copy with any items returned for warranty work. Upon completion of warranty work, if any, we will return the repaired or replaced item or items to you freight prepaid. Damage to our products caused by accidents, fire, vandalism, negligence, misinstallation, misuse, Acts of God, or by defective parts not manufactured by us, is not covered under this warranty.

THE WARRANTY TIME PERIOD IS AS FOLLOWS FOR REPLACE-A-TOP™, SAILCLOTH REPLACE-A-TOP™, SUPERTOP®, SUPERTOP® REPLACEMENT SKINS, SUNRIDER®, AND TIGERTOP®: TWO YEARS FROM DATE OF PURCHASE.

THE WARRANTY TIME PERIOD IS AS FOLLOWS FOR ALL OTHER “SOFT GOODS” MANUFACTURED BY OUR COMPANY (USING PRIMARILY VINYL, PLASTICS, AND/OR FOAM): ONE YEAR FROM DATE OF PURCHASE.

THE WARRANTY TIME PERIOD IS AS FOLLOWS FOR ALL OTHER “HARD GOODS” MANUFACTURED BY OUR COMPANY (USING PRIMARILY METALS, PLASTICS, AND/OR FIBERGLASS): ONE YEAR FROM DATE OF PURCHASE.

ANY IMPLIED WARRANTIES OF MERCHANTABILITY AND/OR FITNESS FOR A PARTICULAR PURPOSE CREATED HEREBY ARE LIMITED IN DURATION TO THE SAME DURATION AND SCOPE AS THE EXPRESS WRITTEN WARRANTY. OUR COMPANY SHALL NOT BE LIABLE FOR ANY INCIDENTAL OR CONSEQUENTIAL DAMAGE.

Some states do not allow limitations on how long an implied warranty lasts, or the exclusion or limitation of incidental or consequential damages, so the above limitations or exclusions may not apply to you. This warranty gives you specific legal rights, and you may also have other rights which vary from state to state.



For further information or request for warranty work, please contact:

Bestop Inc. Customer Service
Toll-Free: (800)845-3567
Main: (303)465-1755
E-mail: csbestop@Bestop.com
Website: www.Bestop.com