



# Installation Instructions JK 2 Door Trektop Halftop

Vehicle Application:  
Jeep® Wrangler JK 2007-2018  
Part Number 53900

## Installation Tips

**Before you begin installing your new Trektop Halftop, please read all the instructions thoroughly.**

For easier installation, the top should be installed at a temperature above 72° F. Below this temperature, the fabric may contract making it difficult to fit the vehicle.

**WARNING** Do not rely in any way on the components of this product to protect against injury or death in the event of an accident. Never operate the vehicle in excess of manufacturer’s specifications.

Read and follow, precisely, all installation instructions provided when installing this product. Failure to do so may result in a poor fit and could place occupants of the vehicle in a potentially dangerous situation.



**CAUTION** Safety glasses should be worn at all times when installing this product.

**WEAR SEAT BELTS AT ALL TIMES**

### Tools



Safety Glasses



#2 Phillips Screwdriver

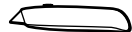

Utility Knife

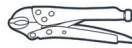

Vise-Grips

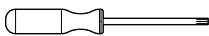

T25 and T40 Torx Driver



8mm and 3/8 " Wrench



Ratchet



Sockets: 3/8" 8mm, 13mm



3mm Allen Wrench

### Installation Time

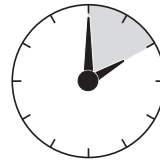

**2 Hours**

### Skill Level



**3 - Moderately Difficult**

### Support

We're here to help!  
Go to [www.Bestop.com](http://www.Bestop.com) and click on "Need Help?"



# Installation Instructions

## JK 2 Door Trektop Halftop

Vehicle Application:  
Jeep® Wrangler JK 2007-2018  
Part Number 53900

### Sugerencias de Instalación

**Antes de empezar a instalar esta unidad, lea atentamente todas las instrucciones.**

**Para un buen ajuste:**

Para facilitar la instalación, el producto debe instalarse a temperaturas superiores a 72 °F (22 °C).

Por debajo de esta temperatura, la tela puede encogerse una pulgada o más, lo que dificultaría su ajuste al vehículo.

Es normal que la tela se contraiga o arrugue cuando está guardada en la caja de empaque. A los pocos días después de la instalación, la tela se relajará y las arrugas desaparecerán.



#### ADVERTENCIA

Este producto se diseñó principalmente para mejorar la apariencia del vehículo y proteger a los ocupantes de las condiciones climáticas comunes. De ninguna manera piense que los componentes de este producto pueden servir como medio de contención para los ocupantes del vehículo o que pueden protegerlos contra lesiones o la muerte en caso de accidente. Este producto no protegerá a los ocupantes contra caídas de objetos. Nunca conduzca este vehículo fuera de las especificaciones del fabricante.

#### USE LOS CINTURONES DE SEGURIDAD EN TODO MOMENTO

Lea y siga con precisión todas las instrucciones de instalación que se proporcionan para instalar este producto. Si no lo hace, podría producirse un mal ajuste que colocaría a los ocupantes del vehículo en una situación potencialmente peligrosa.



#### PRECAUCIÓN

Debe usar gafas protectoras en todo momento durante la instalación de este producto.

### Conseils pour l'installation

**Lire toutes les instructions au complet avant de commencer l'installation de cet assemblage.**

**Pour un ajustement sans problème :**

Afin de faciliter l'installation, ce produit doit être installé à des températures au-dessus de 72 °F (22 °C).

Sous cette température, le tissu peut rétrécir d'un pouce (2,5 cm) ou plus, ce qui rendra l'ajustement sur le véhicule difficile.

Il est normal que le tissu rétrécisse et plisse pendant qu'il est dans la boîte d'expédition. En quelques jours après l'installation, le tissu se détendra et les plis disparaîtront.



#### AVERTISSEMENT

Ce produit est conçu principalement pour améliorer l'apparence du véhicule et pour protéger les occupants des conditions météorologiques usuelles. Ne jamais se fier aux composants de ce produit pour se protéger de blessures ou de la mort en cas d'accident. Ce produit ne protégera pas les occupants des chutes d'objets. Ne jamais utiliser le véhicule au-delà des caractéristiques techniques indiquées par le fabricant.

#### PORTER UNE CEINTURE DE SÉCURITÉ EN TOUT TEMPS

Lire et suivre, très fidèlement, toutes les instructions d'installation fournies lors de l'installation de ce produit. Ne pas suivre cette consigne peut causer une installation inadéquate et mettre les occupants du véhicule dans une situation potentiellement dangereuse.



#### MISE EN GARDE

Des lunettes de sécurité doivent être portées en tout temps lors de l'installation de ce produit.



# Installation Instructions JK 2 Door Trektop Halftop

Vehicle Application:  
Jeep® Wrangler JK 2007-2018  
Part Number 53900

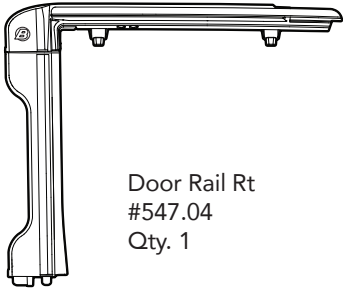

Door Rail Rt  
#547.04  
Qty. 1

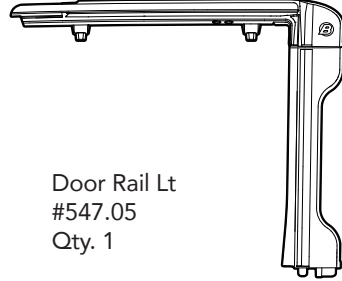

Door Rail Lt  
#547.05  
Qty. 1

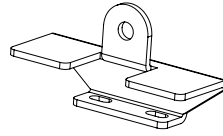

Sunrider Pivot Bracket  
#545.74  
Qty. 2

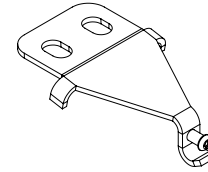

Cable Guide Bracket  
#593.26  
Qty. 2

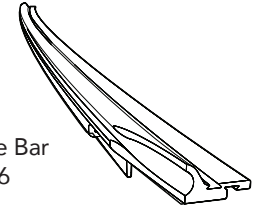

Tailgate Bar  
#538.76  
Qty. 1

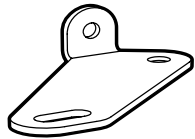

#2 Bow Pivot Bracket  
#541.88 - Right (shown)  
#541.87 - Left  
Qty. 1 per side

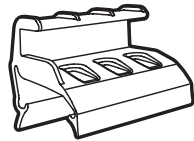

Tailgate Bar Mounts  
#539.57 - Left (shown)  
#539.56 - Right  
Qty. 1 per side

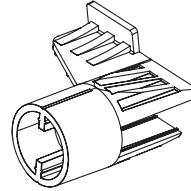

Plastic End Cap  
Part # 592.66 Right (Shown)  
Part # 593.71 Left  
Qty. 1 per side

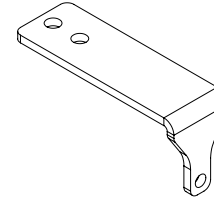

Bracket, Cable Spring Attach  
Part # 629.57  
Qty. 2



Extruded Aluminum Bow  
Qty. 1  
Part # 620.81

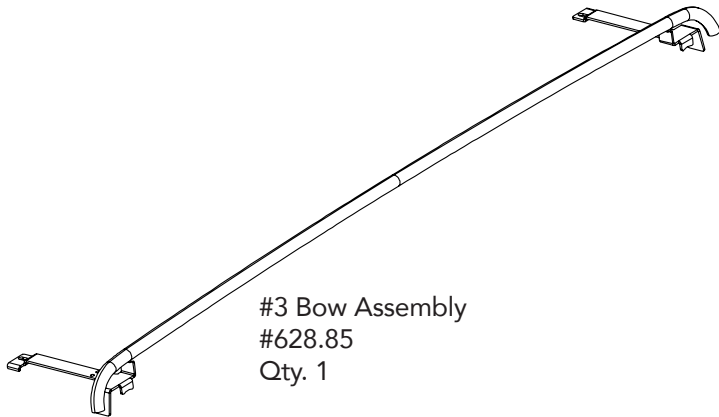

#3 Bow Assembly  
#628.85  
Qty. 1

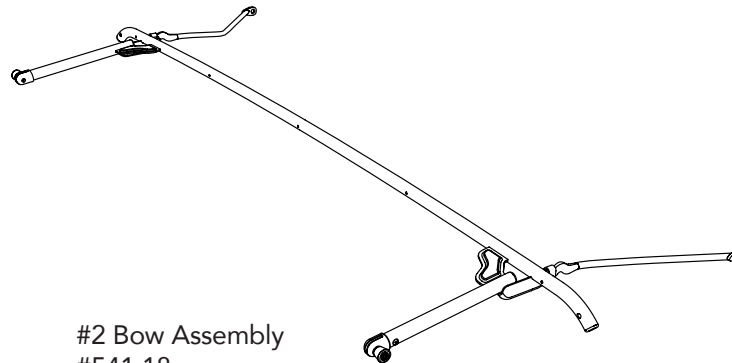

#2 Bow Assembly  
#541.18  
Qty. 1



Bow C Pillar  
Part #629.13  
Qty. 2



# Installation Instructions JK 2 Door Trektop Halftop

Vehicle Application:  
Jeep® Wrangler JK 2007-2018  
Part Number 53900

## Kit # 628.82

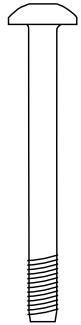

Screw #10-32 x 1/2"  
Part #316.82  
Qty. 4  
#2 Phillips



Lock Nut 10-32  
Part #316.94  
Qty. 4  
3/8" Wrench

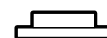
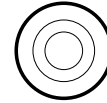

Plastic Bushing  
Part #473.40  
Qty. 4

M8 x 80 Screw  
#532.23  
Qty.4  
T-40



M5 Lock Nut  
Part #308.62  
Qty. 2  
8mm Wrench



#10 Flat Washer  
Part #575.27  
Qty. 2



Adhesive Fabric  
Loop Strips  
Part #606.91  
Qty. 2

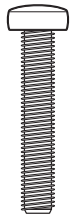

M5 x 35mm Screw  
Part #514.62  
Qty. 2  
3mm Hex Socket



Screw M5 x .8 x 12mm  
Part #531.49  
Qty. 4  
T-25 Torx



M5 Nylon Lock Nut  
Part #526.76  
Qty. 6  
8mm Wrench



Bestop Window Sticker  
Part #338.32  
Qty. 1

## Kit # 488.29P

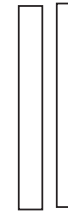

Foam Tape  
Strips  
#417.43  
Qty. 2

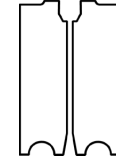

Foam Seals  
#457.76 - Right  
#457.77 - Left  
Qty. 1 per side

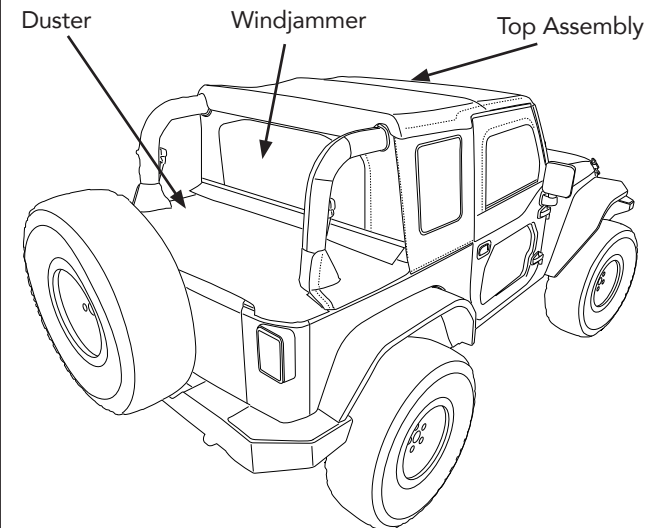



Tools



T40 Torx  
Driver

Parts

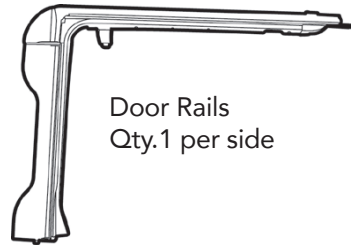

Door Rails  
Qty.1 per side



M8 x 80 Screw  
Qty.4

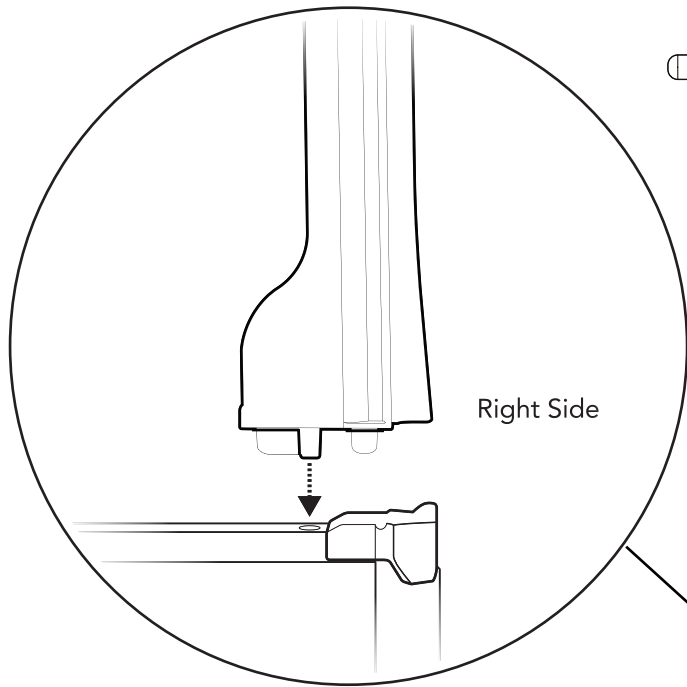

Right Side

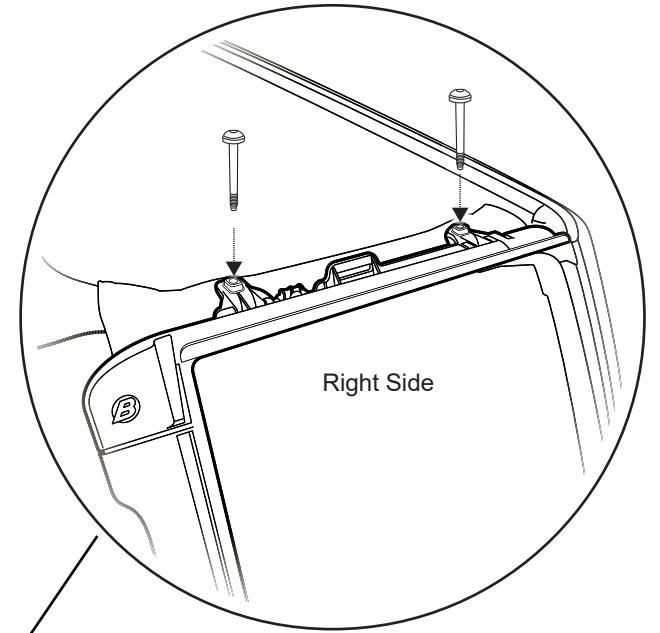

Right Side

Open the passenger side Door.  
Insert the pin in the bottom of the Right  
Door Rail into the hole in the belt rail  
behind the door opening. Press the  
channel along the top of the Door Rail  
around the horizontal sport bar.

Insert one (1) M8 x 80 Screw into each  
position on the right Door Rail.  
Tighten to 55lb/in (4.5(lb/ft).

Repeat on the left side of the vehicle.

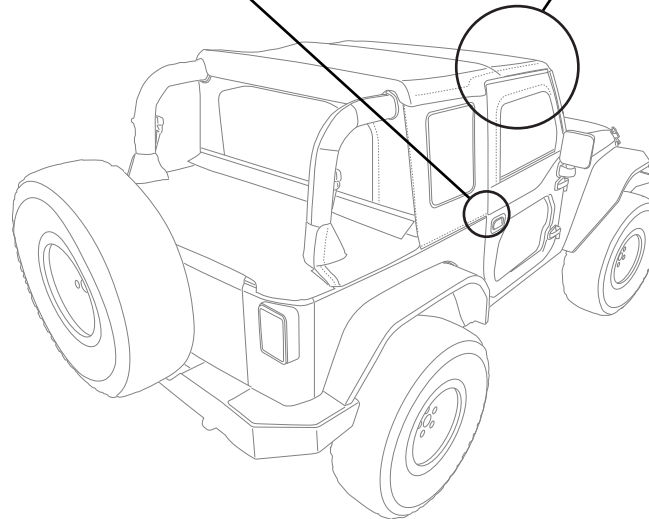

Tools

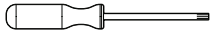

T25 Torx  
Driver



8mm  
Wrench

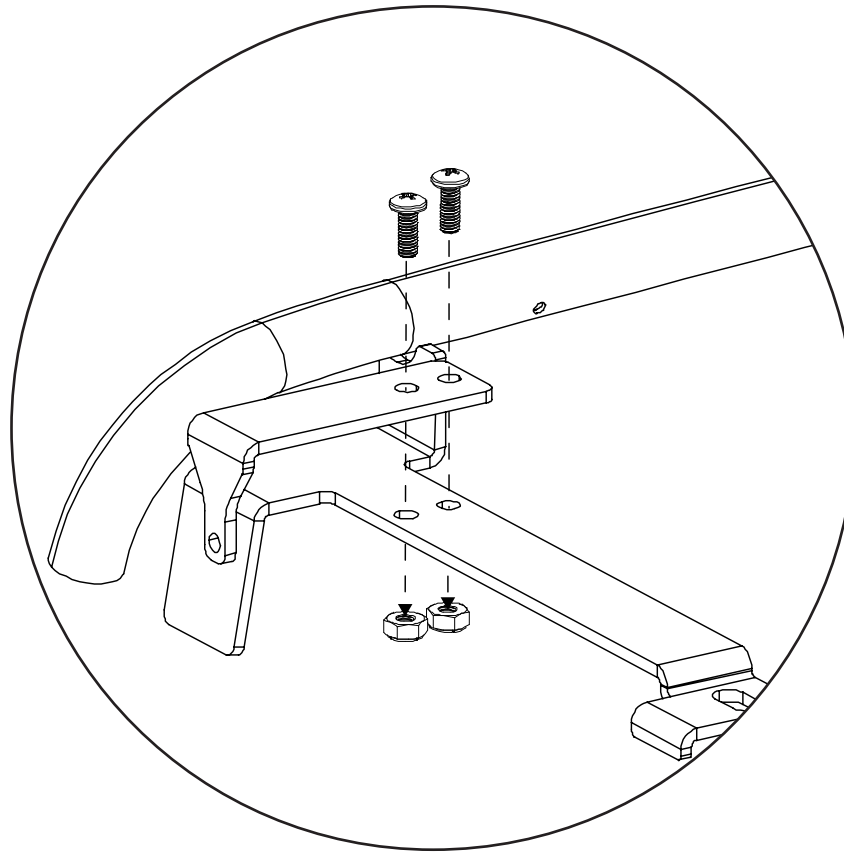

Attach the Cable Spring Attach Brackets to the #3 Bow assembly using two (2) M5 x 12 mm screws and two (2) M5 Nylon Lock Nuts per side.

Parts



Screw, M5 x 12mm  
Qty. 4

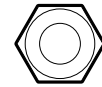

M5 Nylon Lock Nut  
Qty. 4

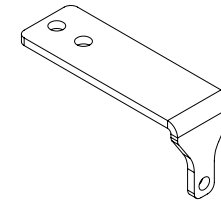
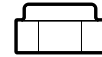

Bracket, Cable Spring Attach  
Qty. 2

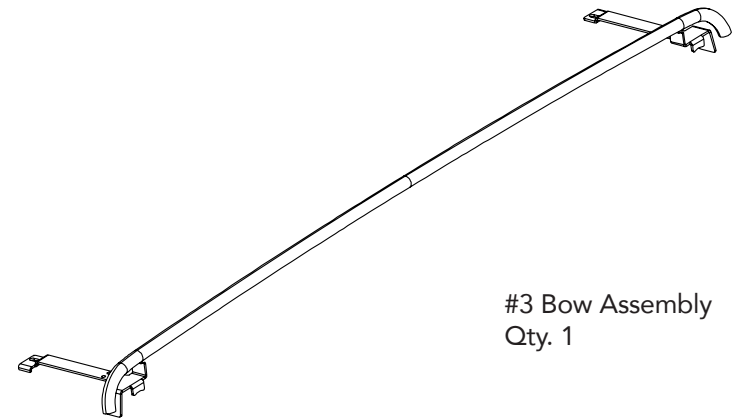

#3 Bow Assembly  
Qty. 1

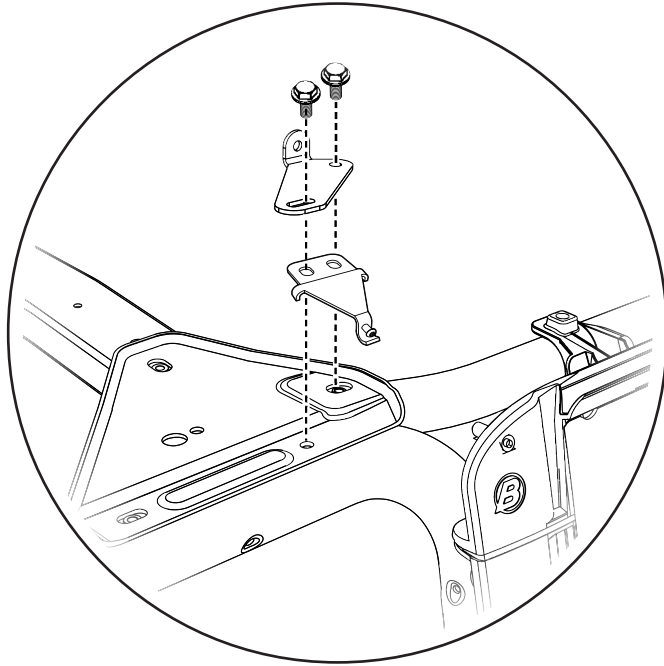

Tools



Parts

#2 Bow Pivot Bracket  
Qty. 1 per side



Cable Guide Bracket  
Qty. 2

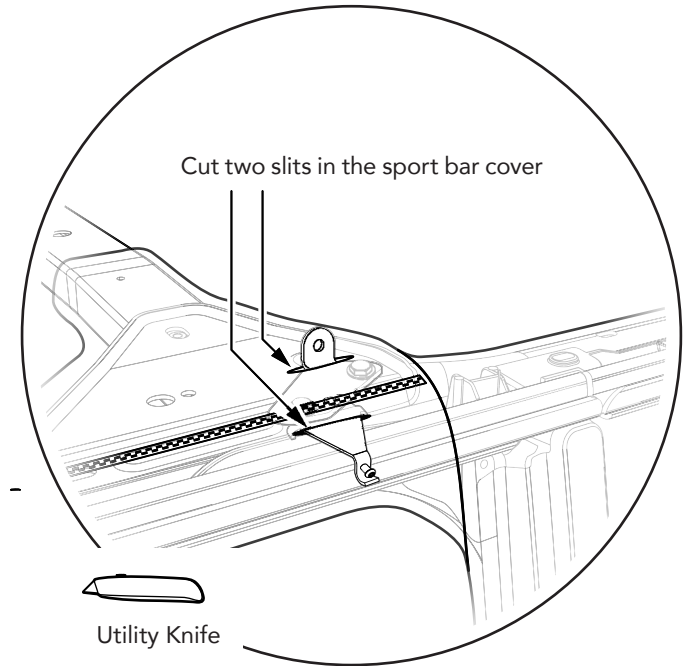
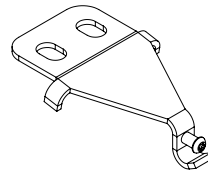

Unzip the sport bar cover over the middle cross bar, to expose the sport bar corner plate, and two hex-head bolts. Attach the Right #2 Bow Pivot Bracket and one (1) Cable Guide Bracket to the right side sport bar plate using the two pre-installed bolts.

Repeat on the left side of the Jeep.

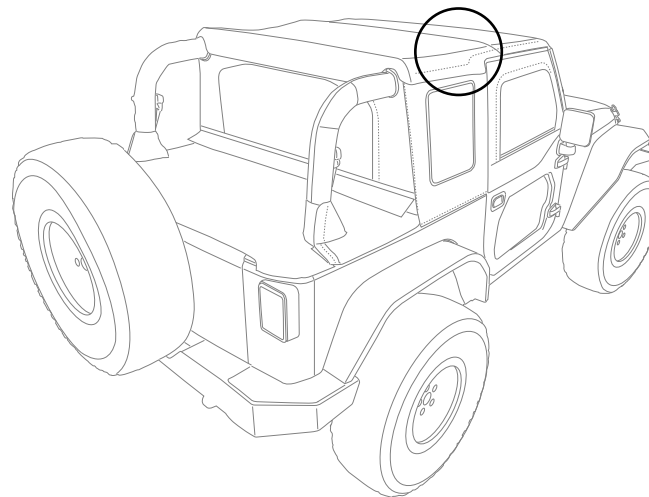

Zip the sport bar cover closed. Locate the vertical tab on the #2 Bow Pivot Bracket, and cut a slit in the cover to allow this tab to protrude through the cover.

Locate the Cable Guide Bracket underneath the sport bar cover, and cut a slit in the cover to allow the bracket to protrude through the cover.

Repeat on the left side of the Jeep.

Locate the rear bolt on the sportbar corner plate.

- ① Slide the zipper towards the outside of the of "the vehicle to clear the bolt head.
- ② Cut a slit in the fabric (Side to Side) 1" wide.

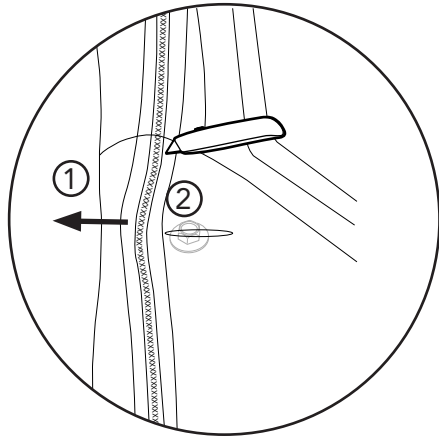

Unzip the sportbar cover. Remove the rear bolt from the factory sportbar.

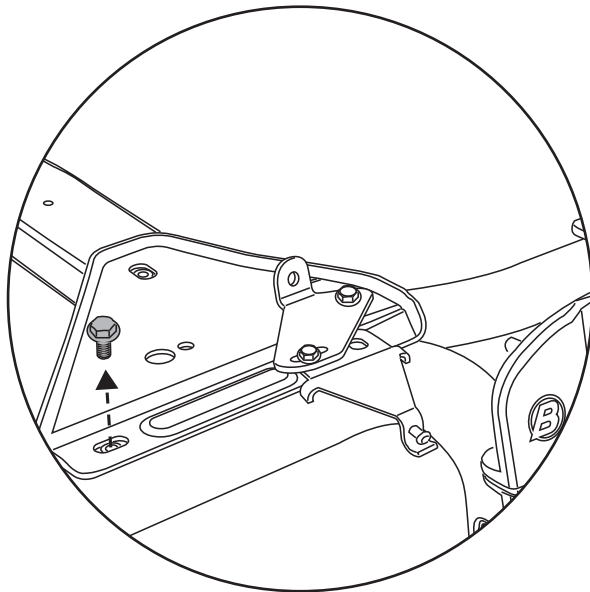

Tools



13mm Wrench



Utility Knife

Slide the upper support bracket through the slit in the sportbar cover. Place the Upper Support Brackets over the hole then replace the bolts. Zip the sportbar cover back up.

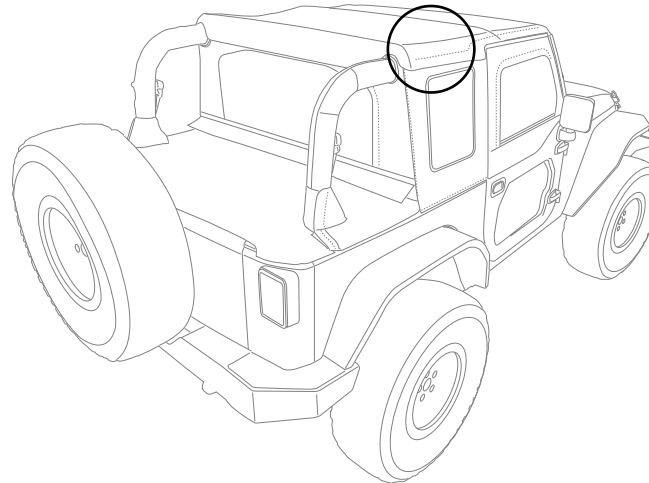
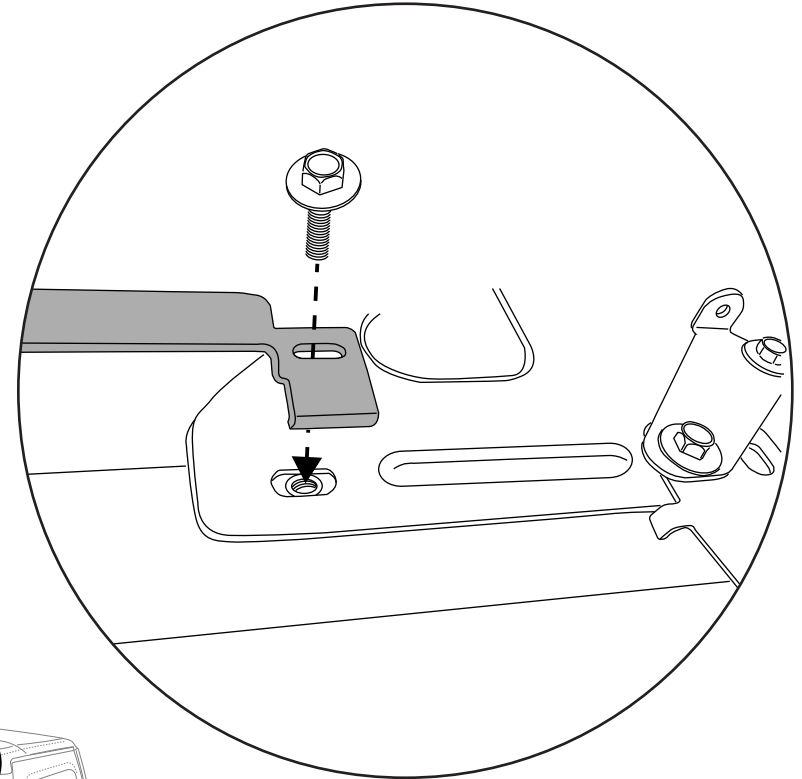

Tools



#2 Phillips  
Screwdriver



3/8" Wrench

Parts

Sunrider Pivot Bracket  
Qty. 2

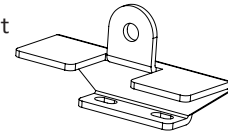

#10-32  
Machine Screw  
Qty. 2 per side



#10-32  
Nylon Lock Nut  
Qty. 2 per side

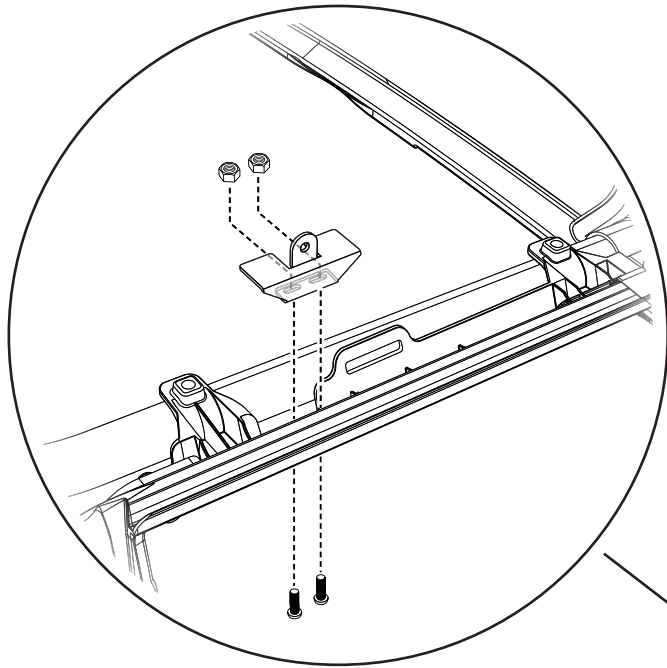

Attach the right Sunrider Pivot Bracket to the Right Door Rail using two (2) #10-32 Machine Screws, and two (2) #10-32 Nylon Lock Nuts.

Repeat on the left side of the vehicle.

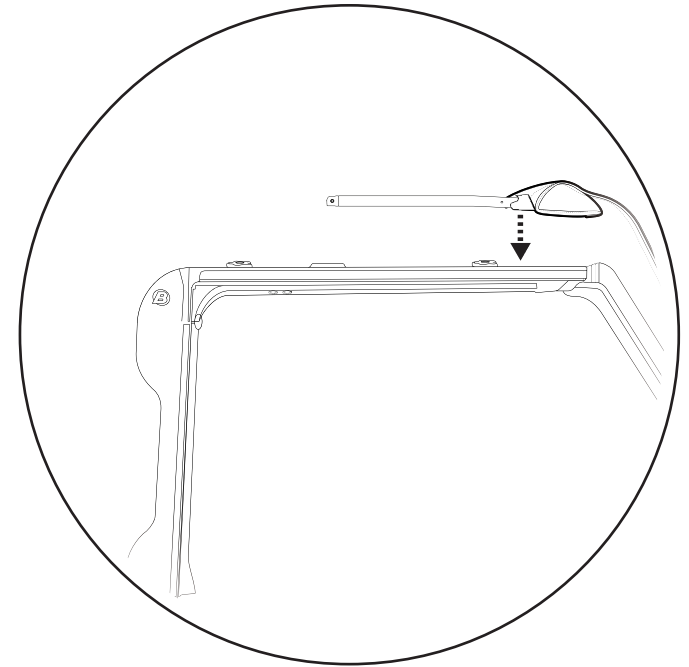

Lift the Header/Side Bow Assembly onto the top of the Jeep, with the Header sitting on top of the Jeep windshield, and the fabric draped forward over the Jeep hood.

You may want to protect the finish of the Jeep by putting a blanket across the Jeep Hood.

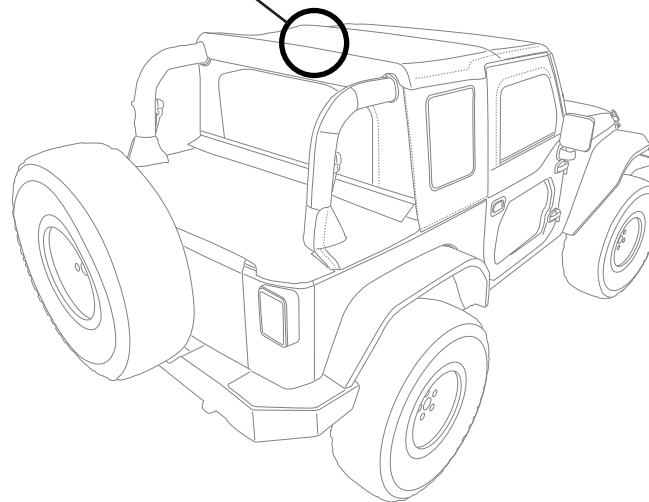

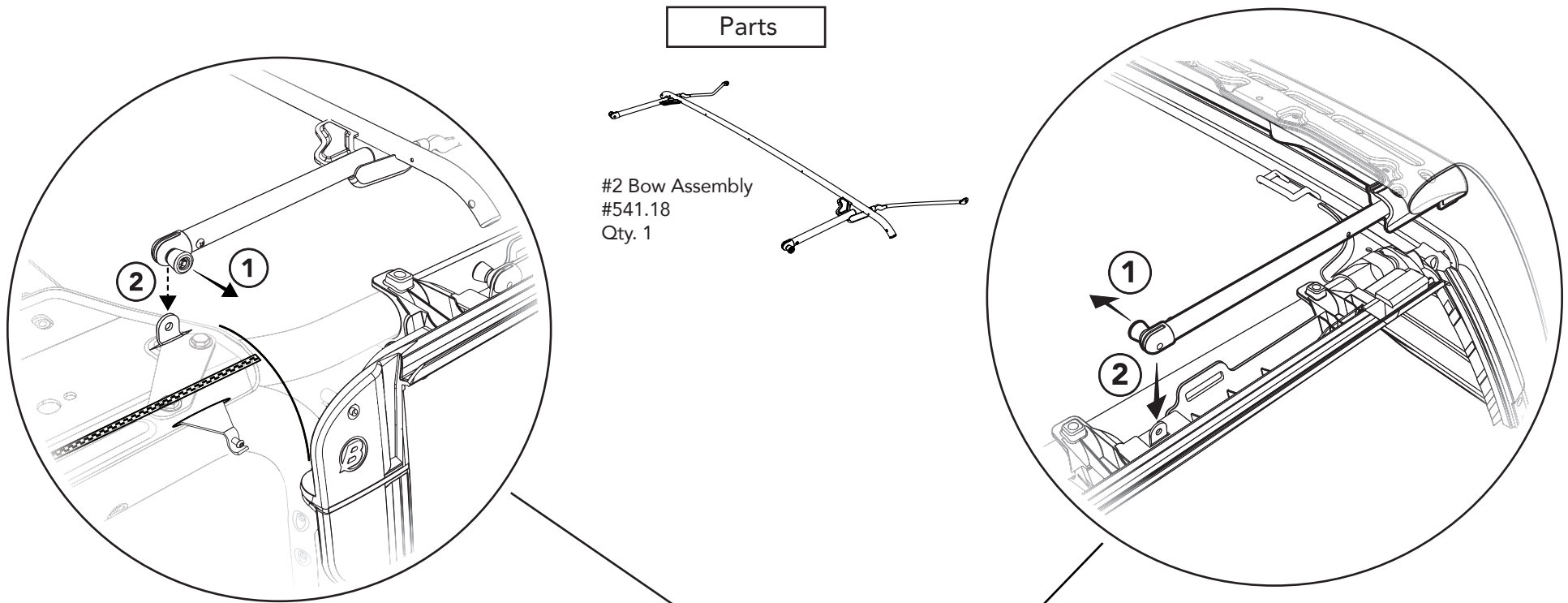

- ① Pull out on the knob to release the spring-loaded catch on the #2 Bow rear legs;
- ② Slide the slotted end of the catch over the #2 Bow Pivot Bracket tab protruding from the sport bar cover.  
Make sure that the spring catch snaps into place on each #2 Bow Pivot Bracket tab.

Attach the right Side Bow to the Right Sunrider Pivot Bracket.

- ① Pull out on the spring catch release knob;
- ② Slide the slotted end of the Side Bow over the vertical tab on the Side Bow Pivot Bracket, and release the knob, making sure that the catch snaps into place on the Pivot Bracket tab.  
Repeat on the left side of the Jeep.

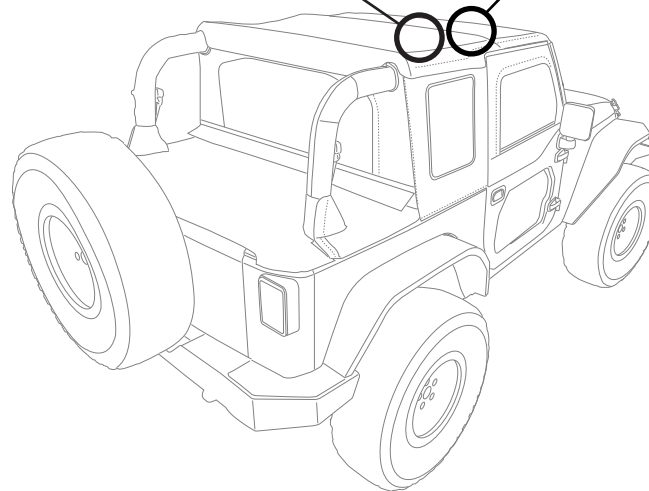



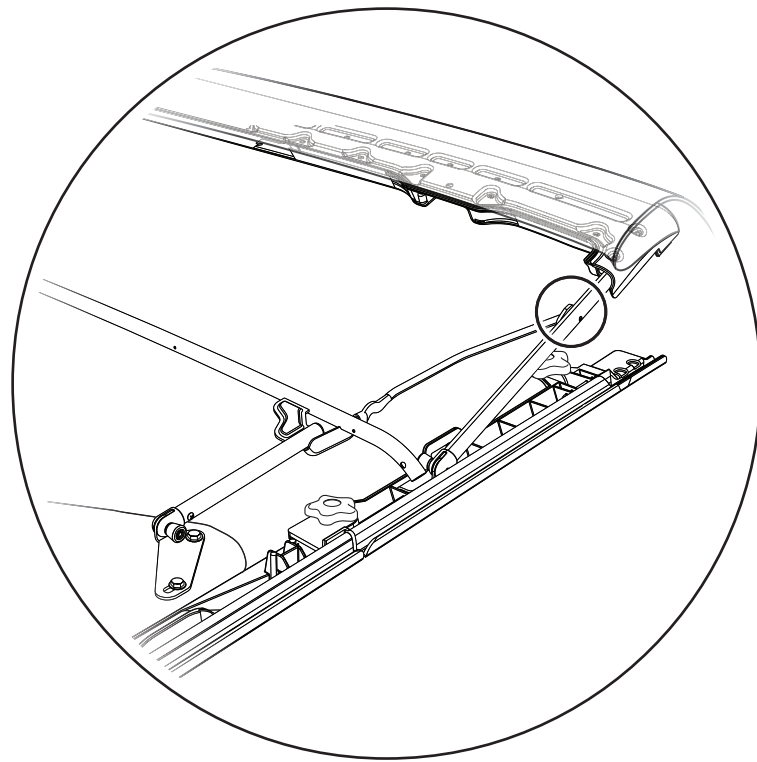

Tools



Parts

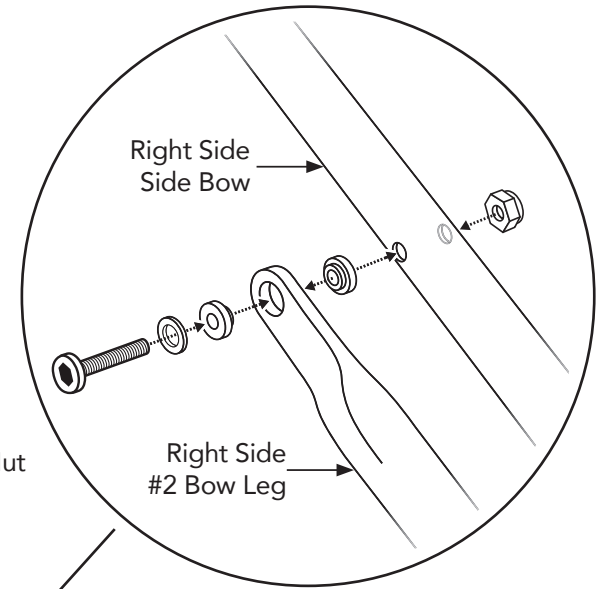
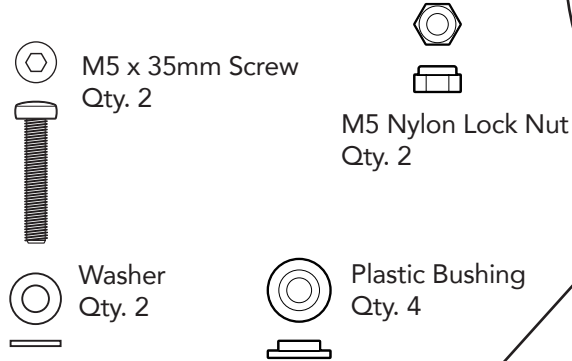

Lift the Side Bow/Header up and locate the hole in the right Side Bow near the Header. Using this hole in the Side Bow, attach the #2 Bow to the right Side Bow. Secure the #2 Bow to the Side Bow using one (1) M5 x 35mm Machine Screw, two (2) Plastic Bushings, one (1) M5 Nylon Lock Nut and one (1) Washer on each side of the vehicle. The Plastic Bushings go on both sides of the flat portion of the #2 Bow leg. The Nylon Lock Nut goes on the inboard side of the Side Bow.

Repeat on the left side of the Jeep.

**NOTE:** Do not overtighten, to avoid damaging the plastic bushings.

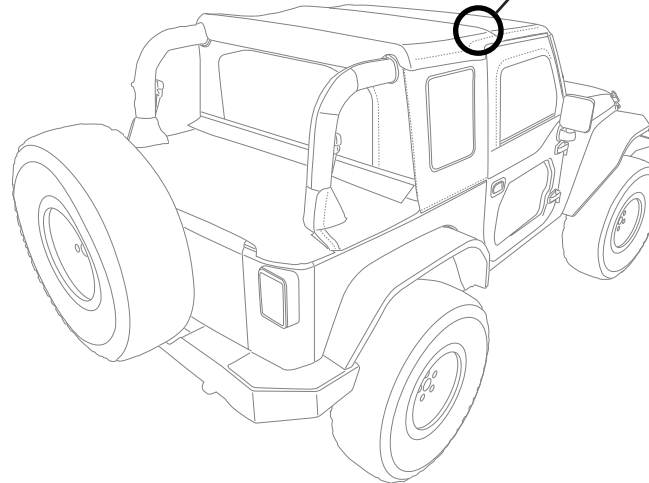

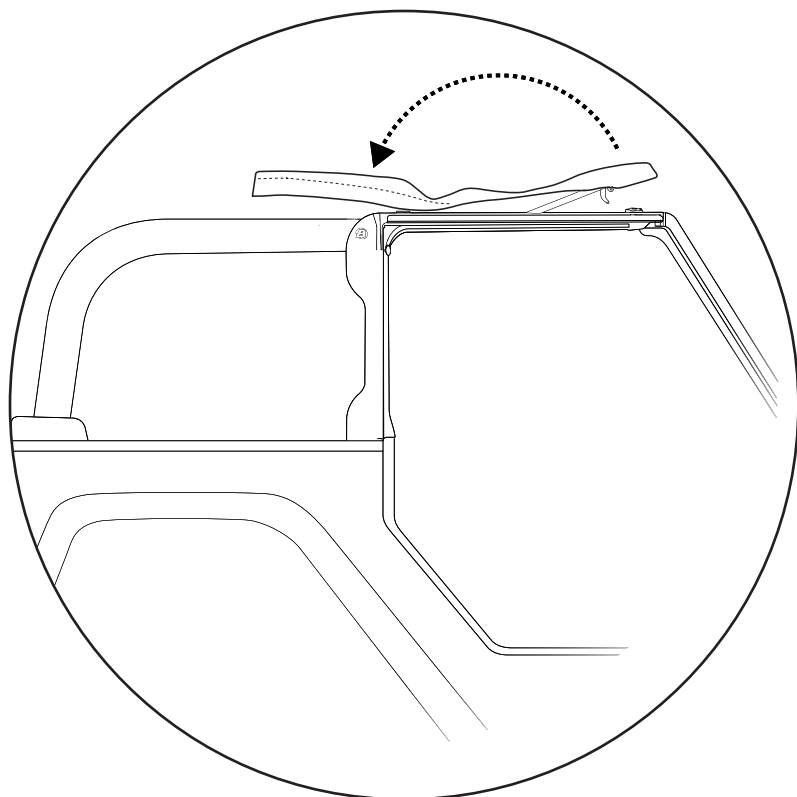

Lift up the fabric and drape it back over the top of the Jeep, pulling it back and over the top of the Rear Bow Assembly.  
 Open the Sunrider. Fold the Sunrider back from the front pivot point, resting the front portion of the top on the rear portion.

Parts

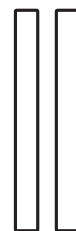

Foam Tape Strips  
 Qty. 2

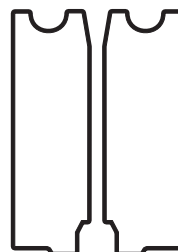

Foam Seals  
 Qty. 1 per side

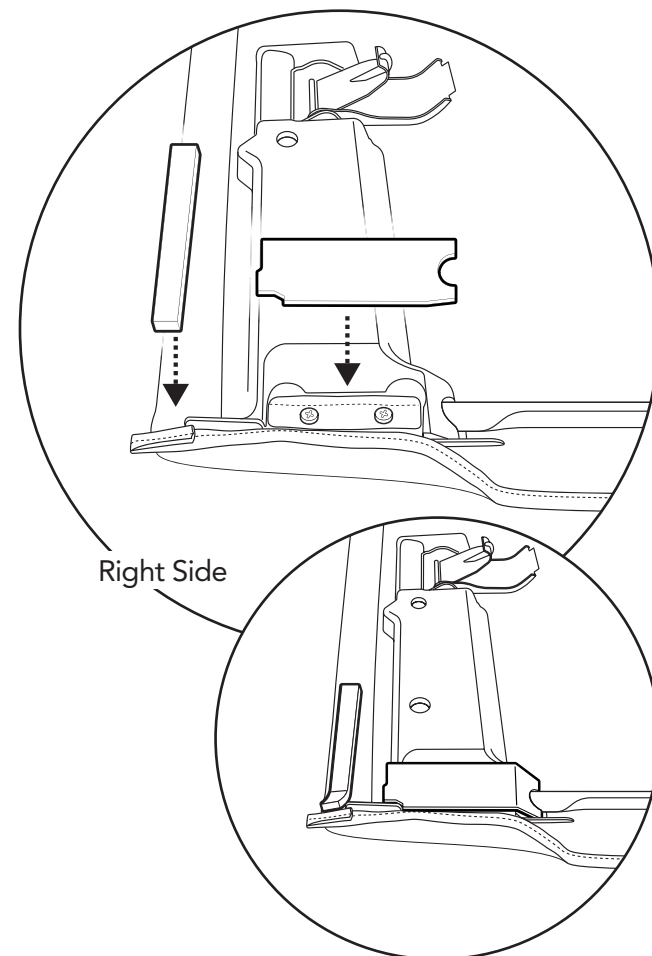

Right Side

With the Sunrider folded back, locate the two (2) Foam Seals and the two (2) Foam Tape Strips.

Remove protective liner from the back side of the Foam Seal and place the Foam Seal in the location shown in the diagram.

Remove protective liner from the back side of the Foam Tape Strip and place the Foam Tape Strip in the location shown in the diagram.

Repeat for the left side of the vehicle.

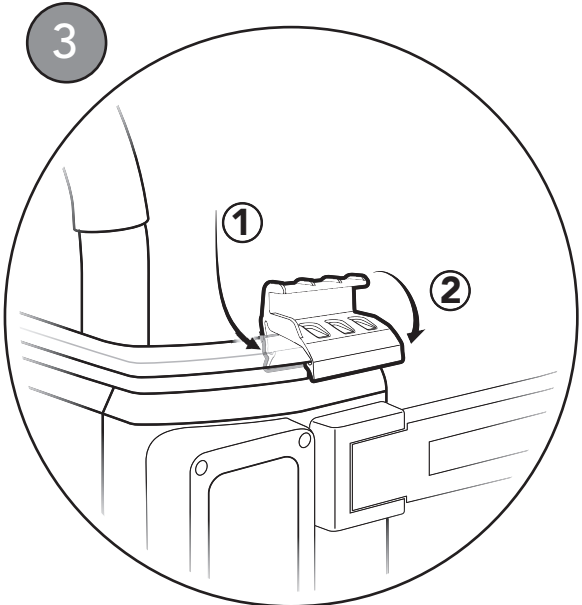
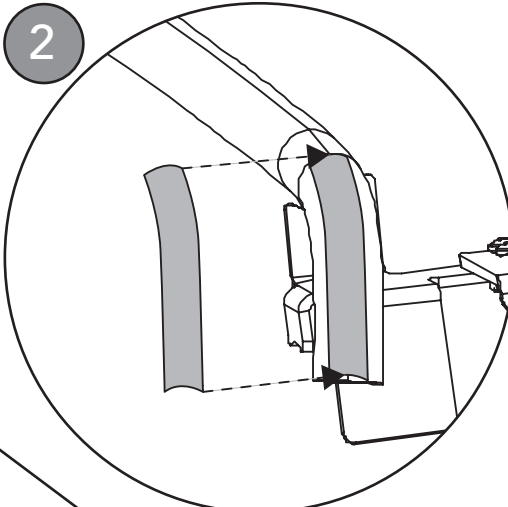
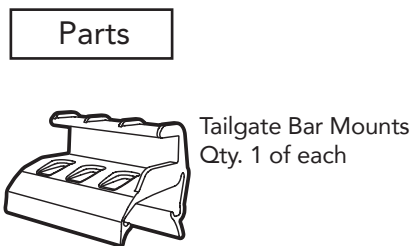
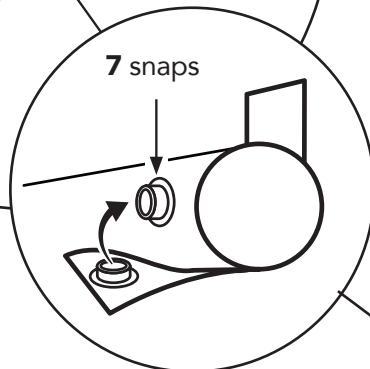
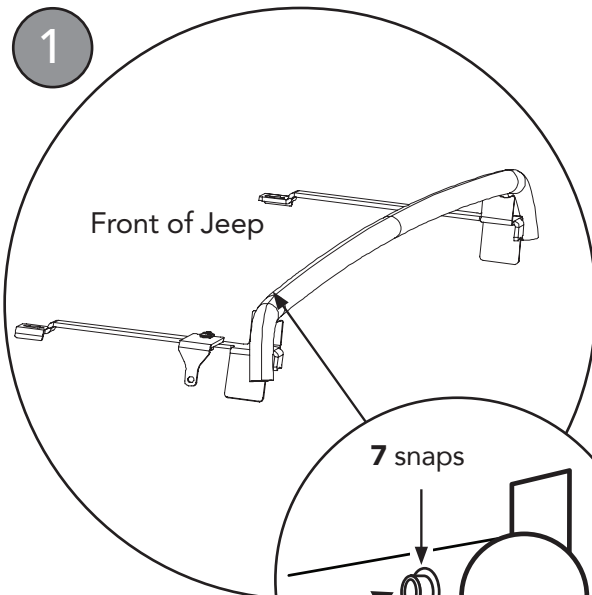

1 From inside the Jeep, wrap the flap located underneath the #3 Bow under the #3 Bow from the back, and snap the seven (7) snaps on the fabric flap to the snaps on the front-facing side of the #3 Bow.

2 Attach one (1) Adhesive Fabric Loop Strip #606.91 to each end of the Rear Bow as shown. The Loop Strips should align with the Hook Strips on the underside of the fabric top. Repeat on left side of vehicle.

3 Snap each mount into place:  
 ① Hook the inner catch portion of the mount under the belt rail on the inside of the tailgate, and then  
 ② Roll the mount downward until it snaps into place under the bottom edge of the outside belt rail.

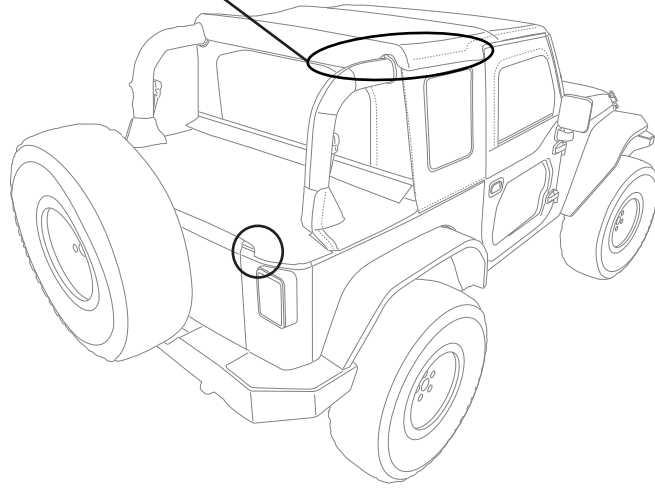

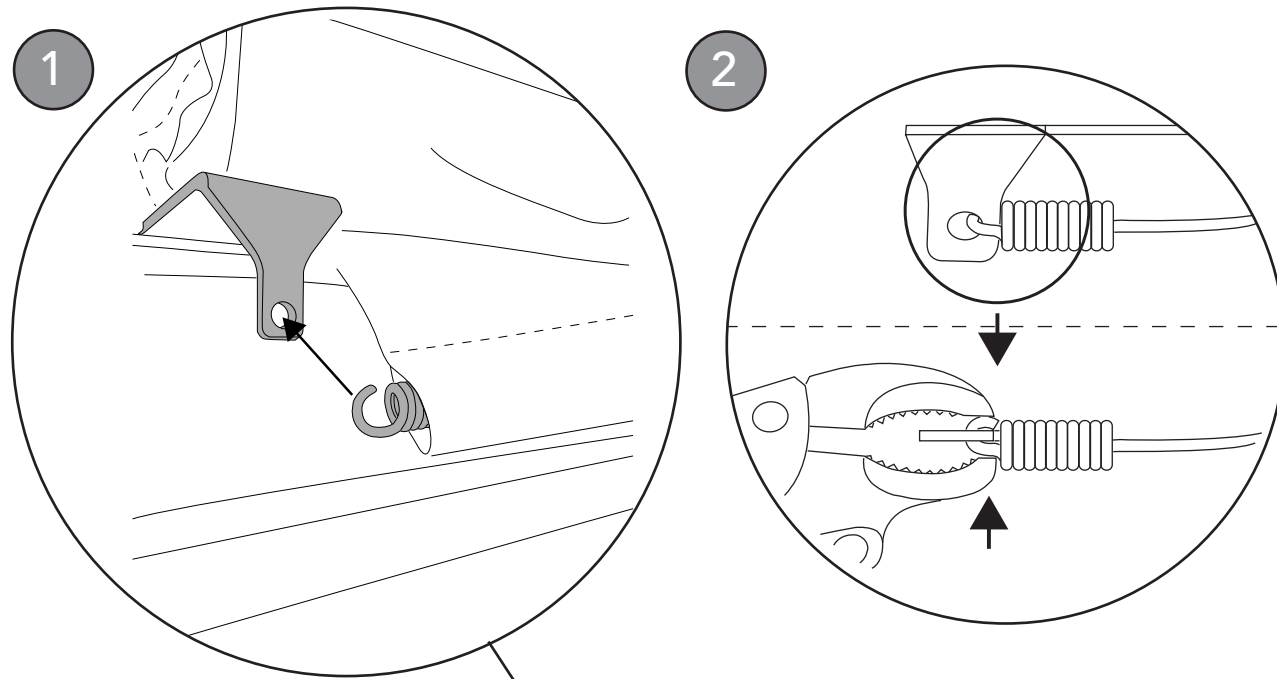
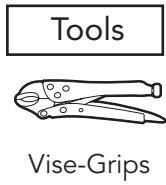

1

Attach the free end of the Cable Spring to the bottom hole in the #3 Bow corner plate, just above the bend in the rear leg of the sport bar.

2

Crimp the end of the spring where it passes through the hole in the #3 Bow corner plate, to prevent it from coming loose.

Repeat on the other side of the vehicle.

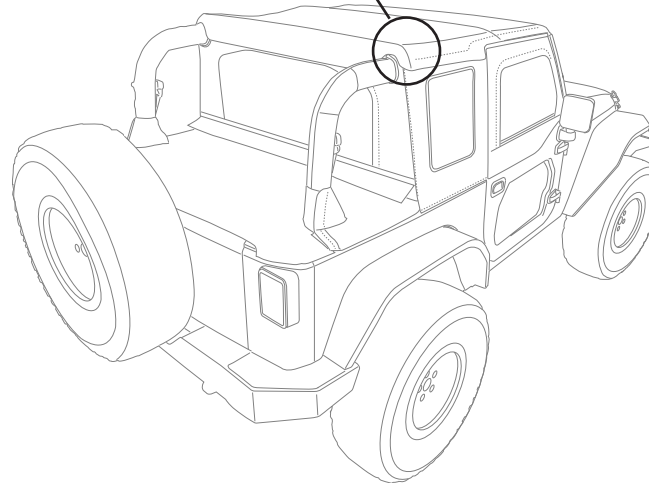

1

Starting on the side of the duster without the pull tabs, roll the Duster up loosely. The side of the Duster with the pull tabs is the front edge.

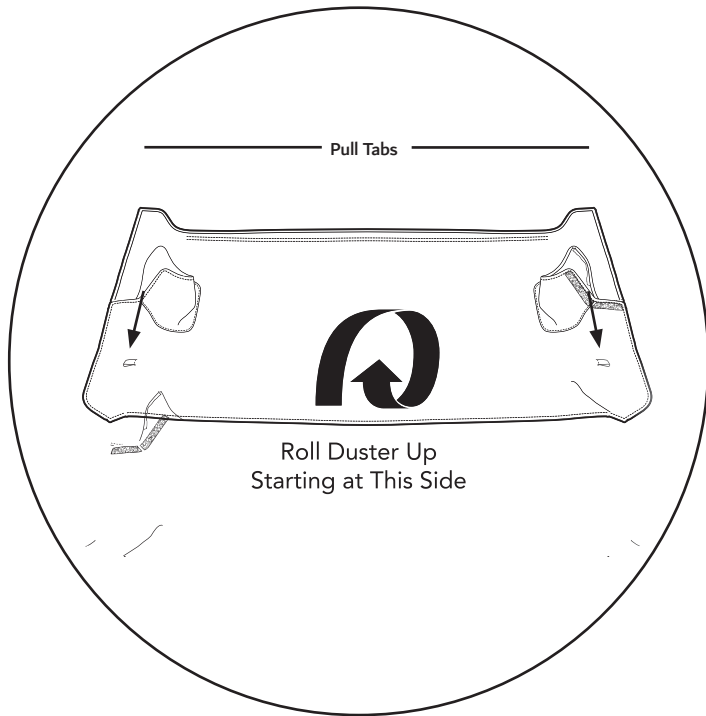

Parts

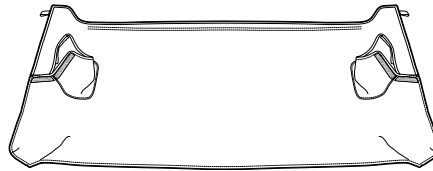

Duster Qty. 1

2

With the Duster loosely rolled up, slide the P-Extrusion along the exposed front edge of the Duster into the top slot of the Extruded Aluminum Bow, using the slot in the Bow that is on top of the arch and facing up.

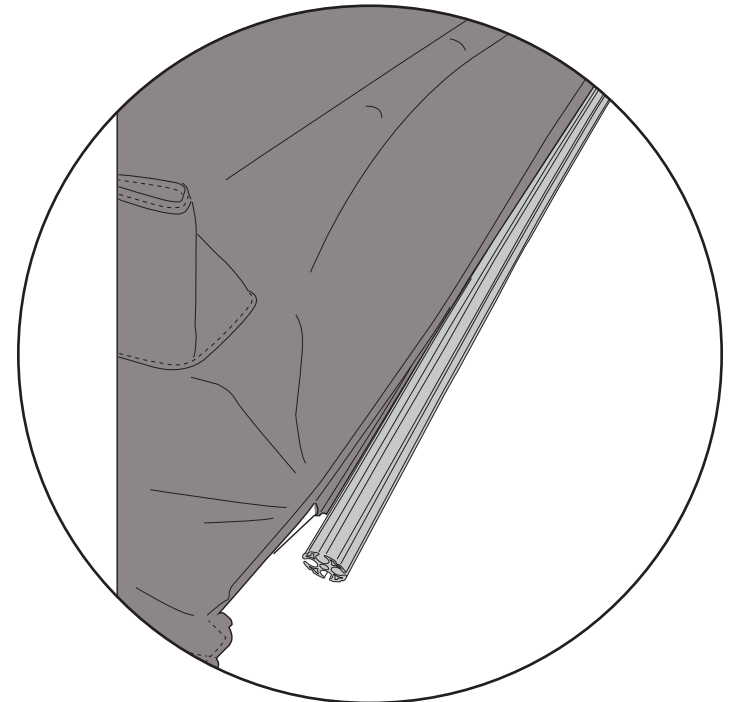
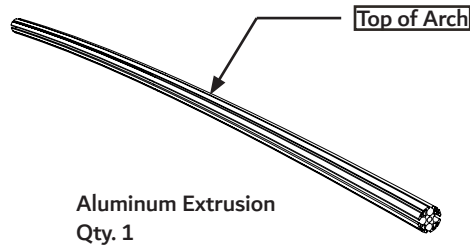

**NOTE:** Aluminium Extrusion has arch. The Duster should be in the top part of the arch.

Slide the sewn in P-extrusion into the front channel of the Aluminium Extrusion.

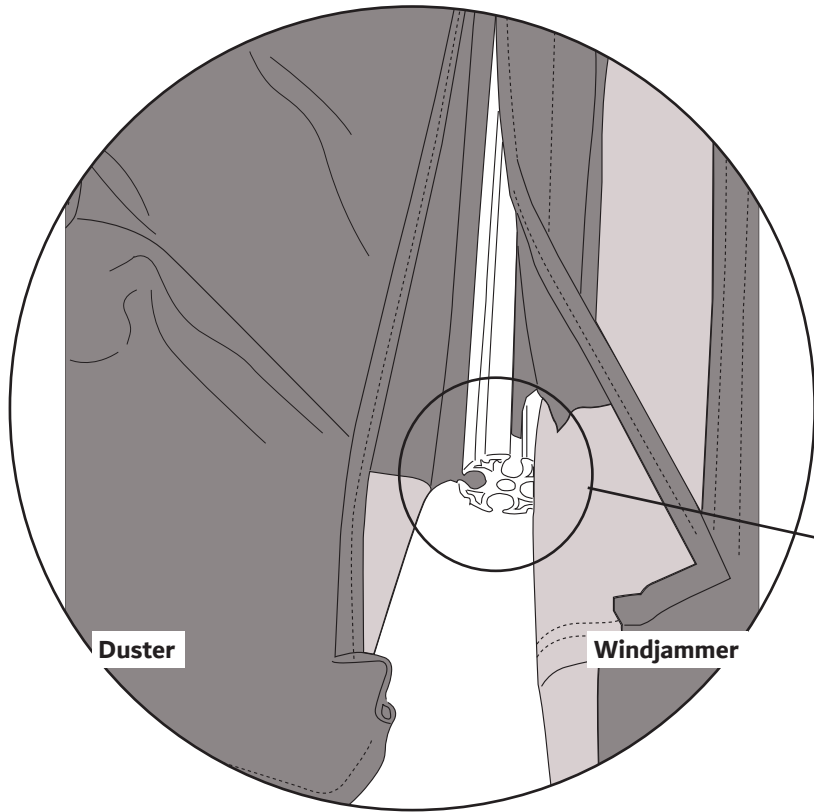

Parts

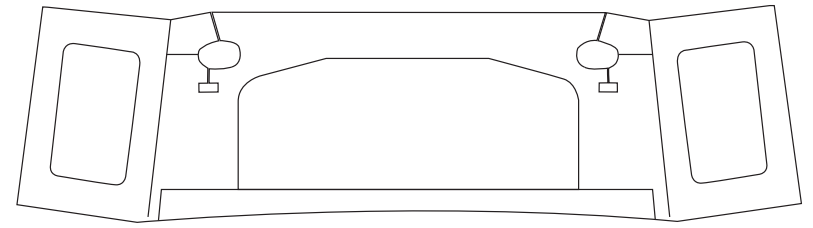

Windjammer Assembly

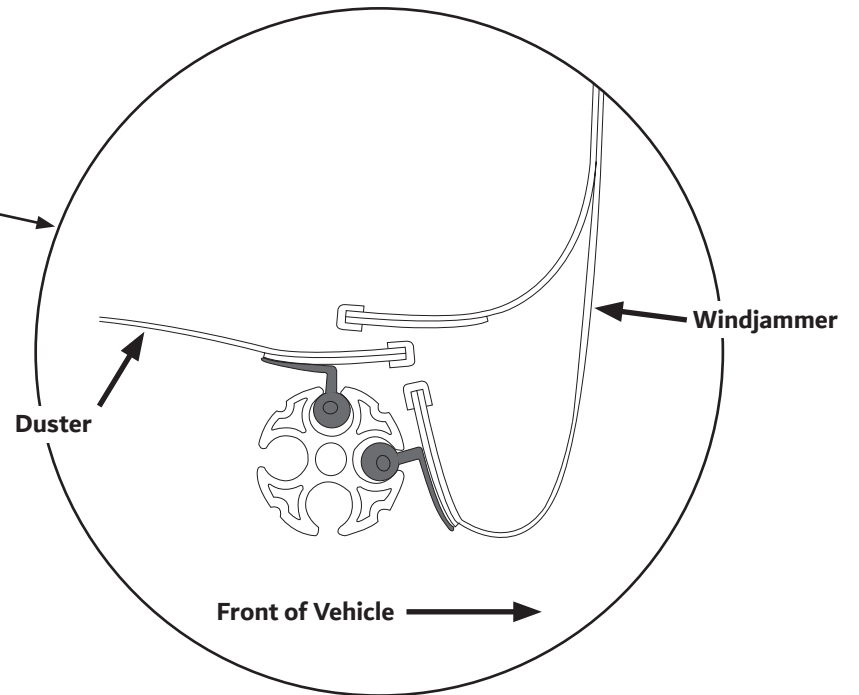



Slide the Rubber Retainer located at the top (Center Section) of the Windjammer into the Plastic "C" channel located at the rear of the Top (Under the rear flap) until the Windjammer is centered on the Top.

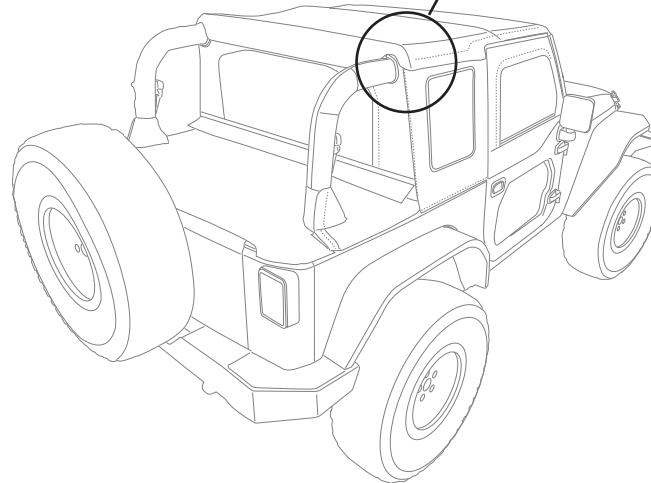
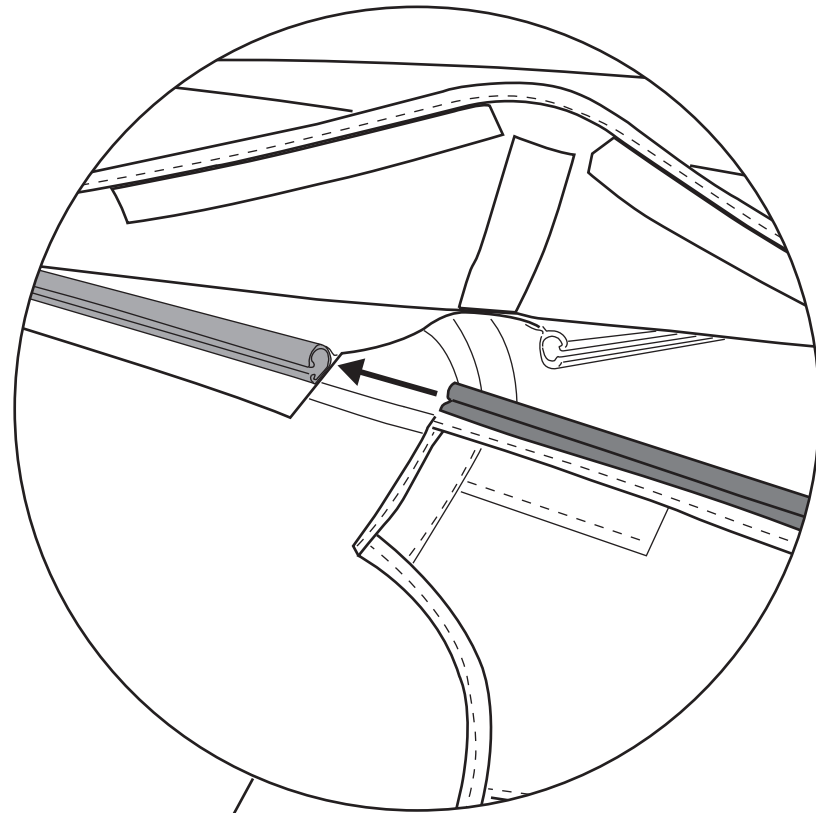

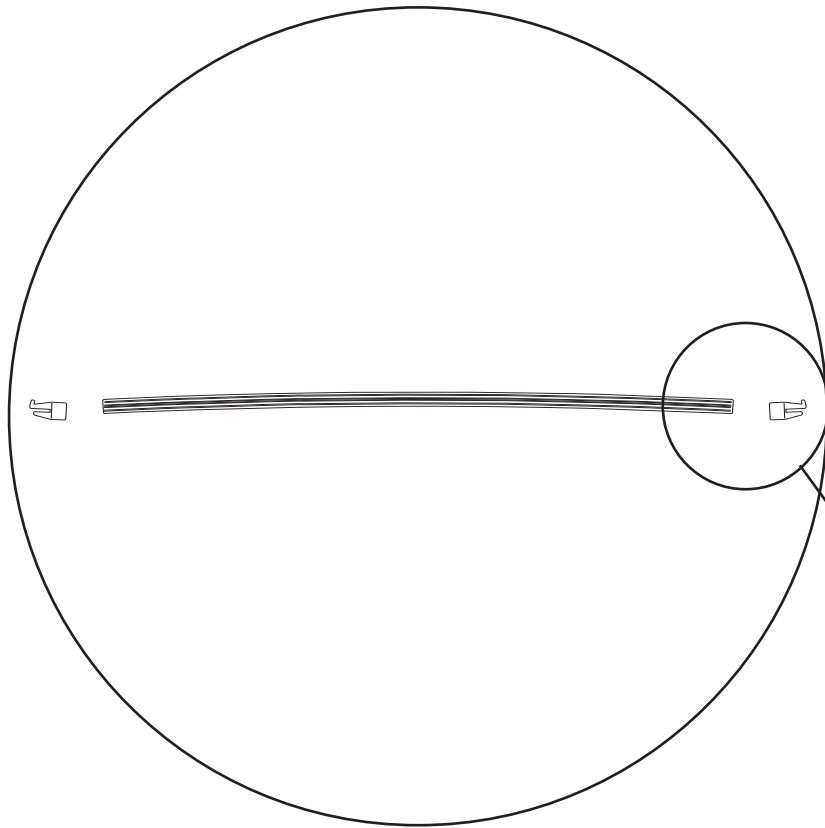

Place the Plastic End Caps on the passenger side of the Aluminium Extrusion and on the driver side. The internal ribs inside the round opening of each end cap will slide into the slots on the top and bottom of the aluminum extrusion.

Parts

Plastic End Cap - Left  
Qty. 1

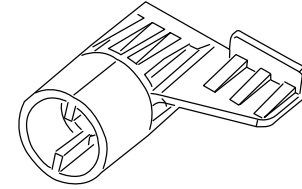

Plastic End Cap - Right  
Qty. 1

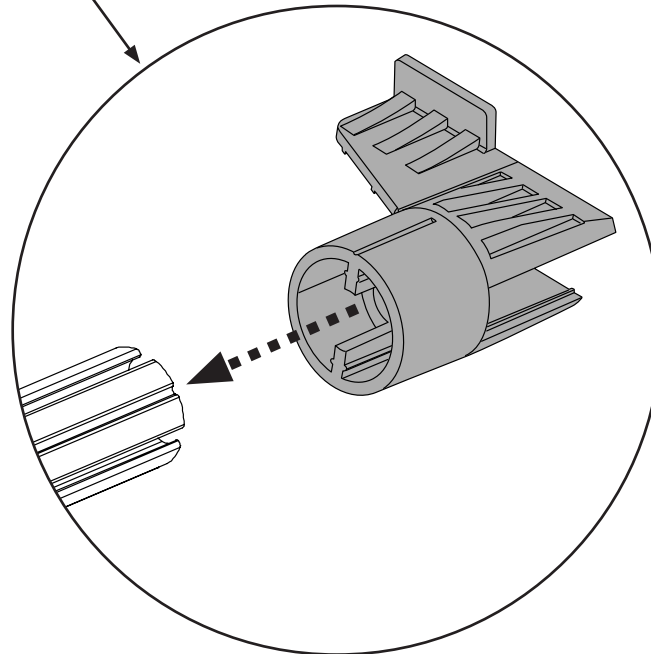
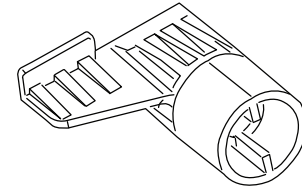

**NOTE:** The Wing must go towards the front of the vehicle with the Tab pointing up.

1

Fold both rear seats forward. (Refer to Owners Manual)  
Set End Cap as far rearward on the driver side then set the other end cap as far forward as possible on the passenger side.

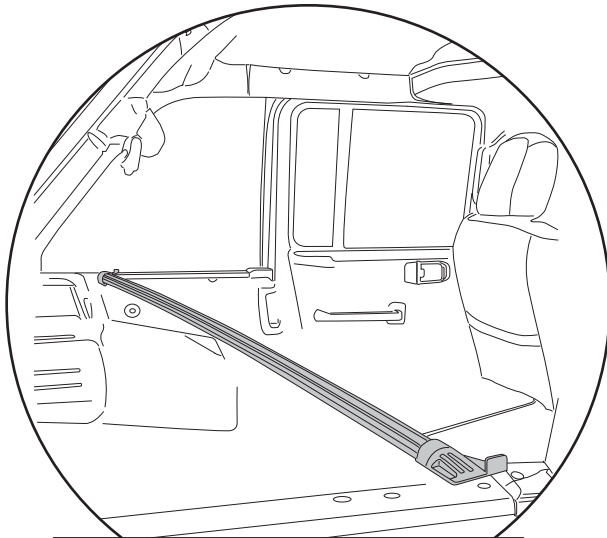

Fabric not shown for illustration purpose only.

2

Slide the Bow End forward (Driver Side) and Rearward (Passenger Side) until you reach the 20 inch dimension from the front of the Extrusion to the front edge of the Rubber Seal at the top and rear of the door opening.

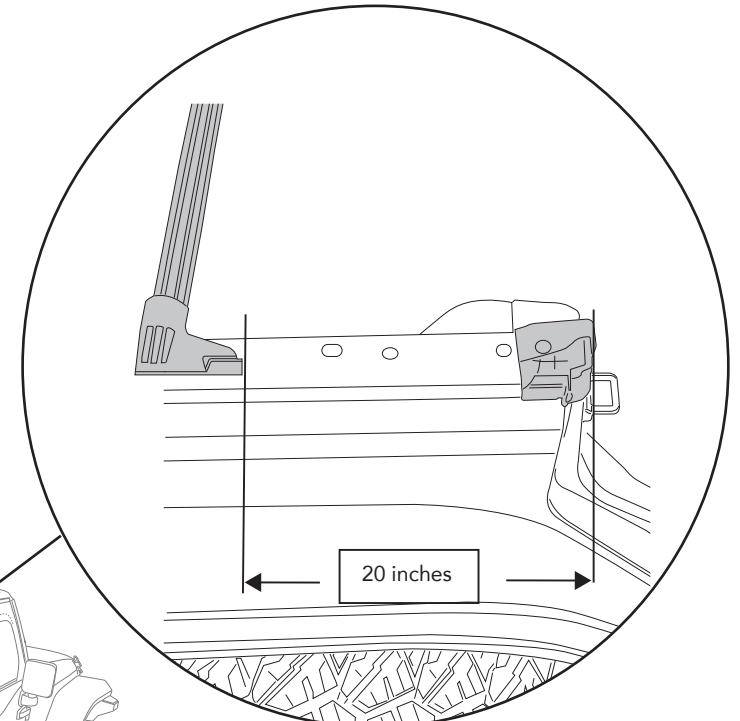

**NOTE:** 20 inches is the starting point for the Bow End location. You will be able to move the Bow Ends forward or backwards for small adjustments as necessary..

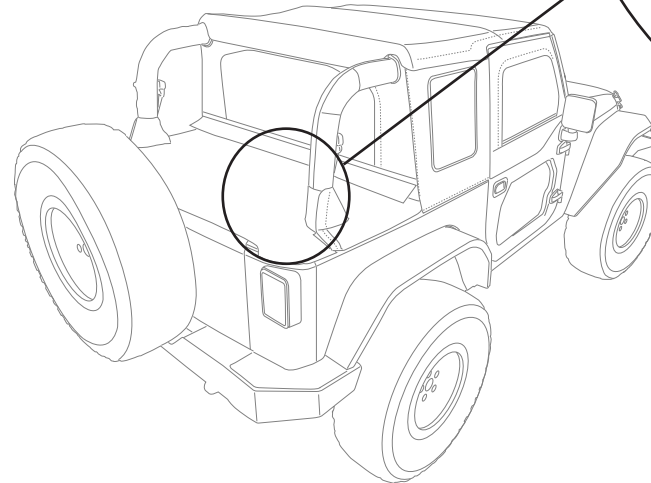

1

Insert the top of the C Pillar Bow (Part # 629.13) onto the Bow Support Bracket and push it all of the way up.

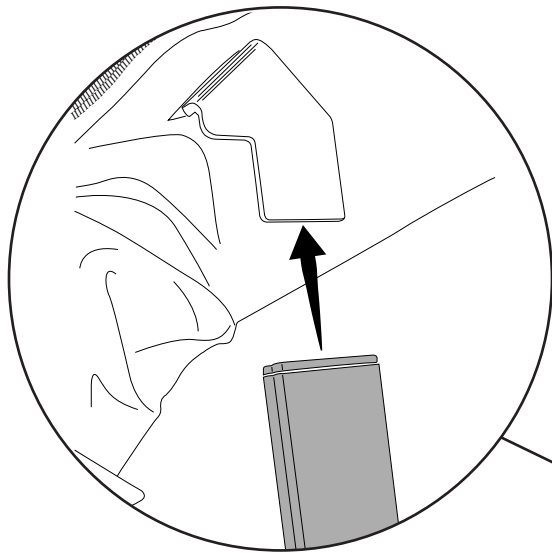

Parts



Bow C Pillar  
Part #629.13  
Qty. 2

2

Align the C Pillar Bow with the tab on the End Cap then pull the C Pillar bow down onto the tab.

Repeat the steps on left side of the vehicle.

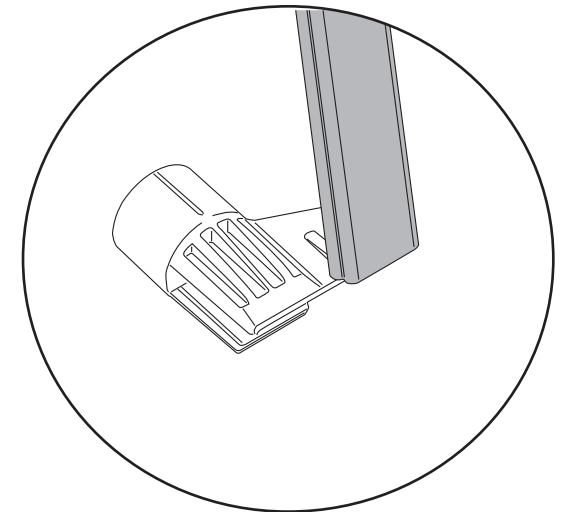
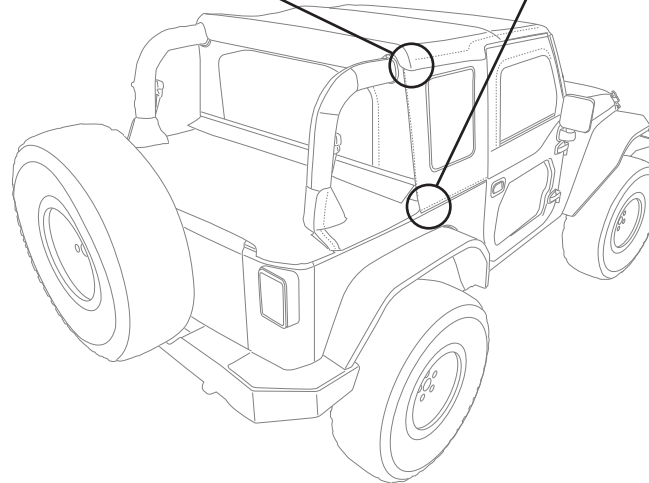
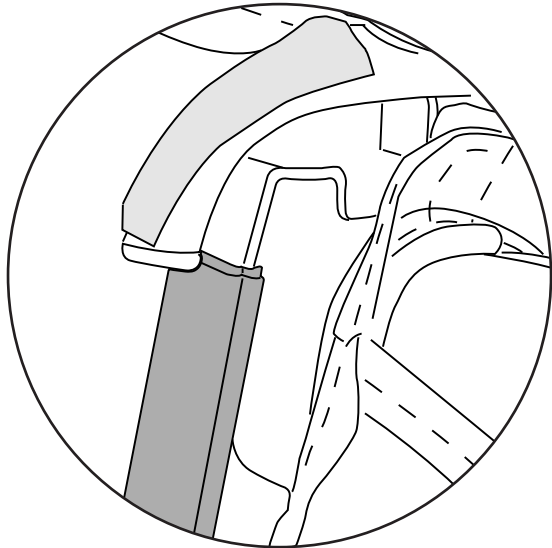
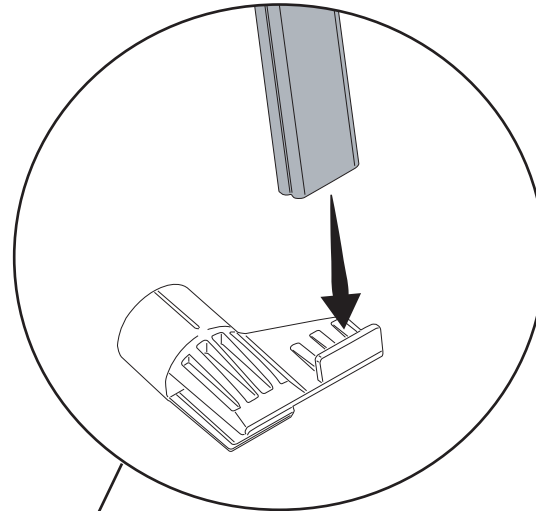

1

Slide the "C" Channel Retainer located along the top of the Side Panel onto the plastic retainer located on the top.

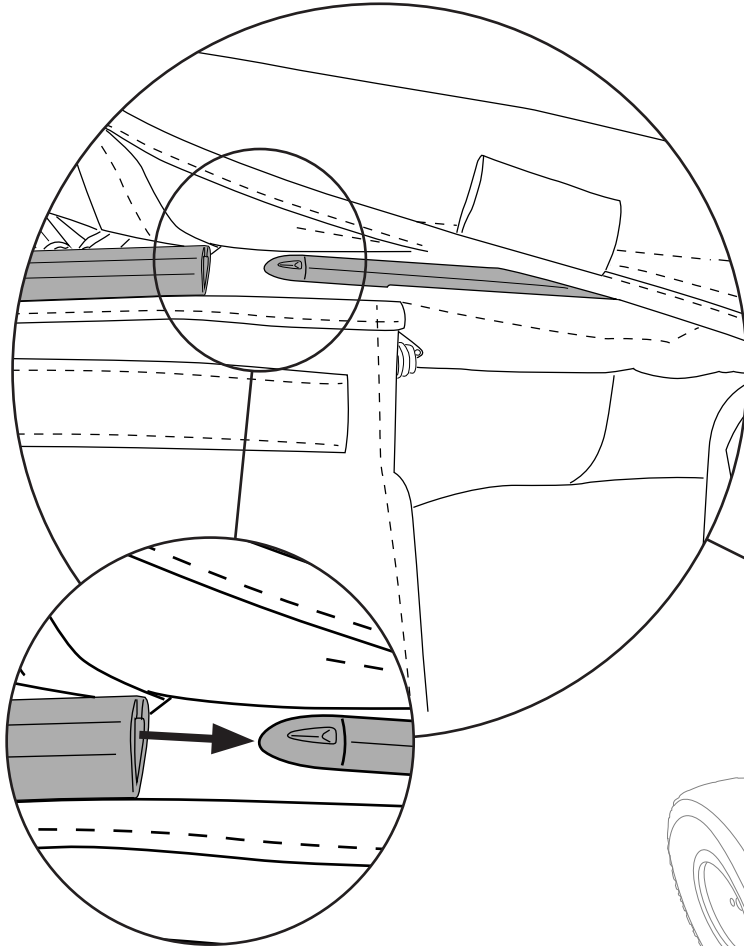

2

Locate the sewn-in plastic strip along the front edge of the Side Panel.

Tuck the plastic angle strip along the front edge of the Side Window into the vertical channel in the front of the Door Rail. The plastic angle strip and attached fabric must be rolled into place in the channel.

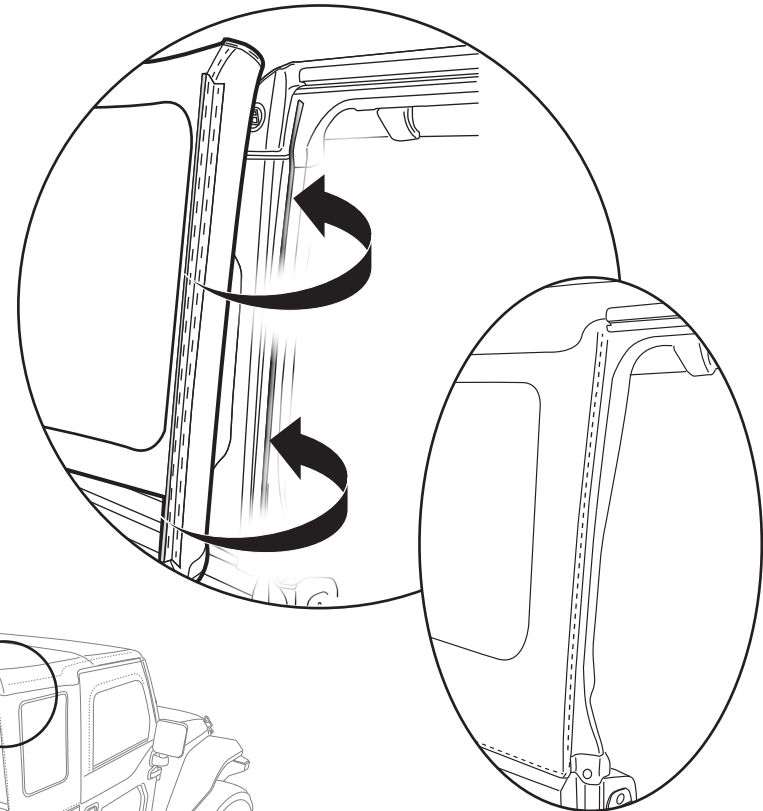

When installed correctly, there will be only one (1) stitch line visible and it will be facing the door opening.

Repeat on left side of vehicle.

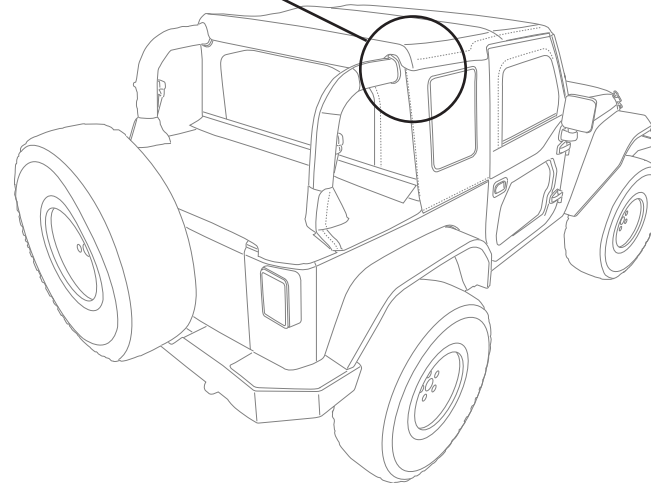

Attach the Tailgate Bar to the sewn-in P-Extrusion rail on the underside of the rear of the Duster. Slide the Tailgate Bar all the way across the "P" extrusion. (As it was on the rear window of the Trektop)

Parts

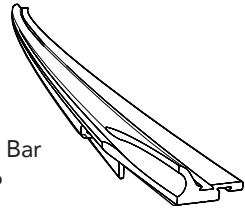

Tailgate Bar  
#538.76  
Qty. 1

Secure the Tailgate Bar with attached Duster to the Tailgate Bar Retainers. Press the Tailgate Bar into the receiver on each Tailgate Bar Retainer.

**NOTE:** The bulb seal on the Tailgate bar must hang below the bar and face rearward for the tailgate to touch it.

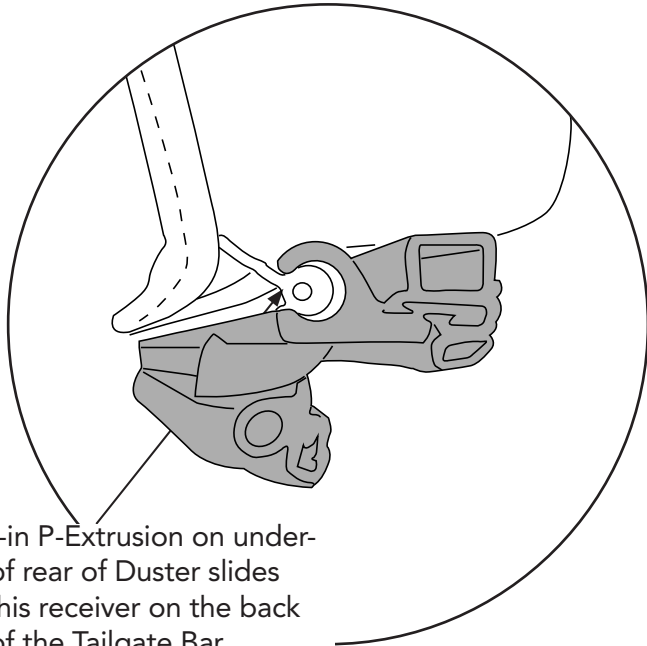

Sewn-in P-Extrusion on underside of rear of Duster slides into this receiver on the back side of the Tailgate Bar.

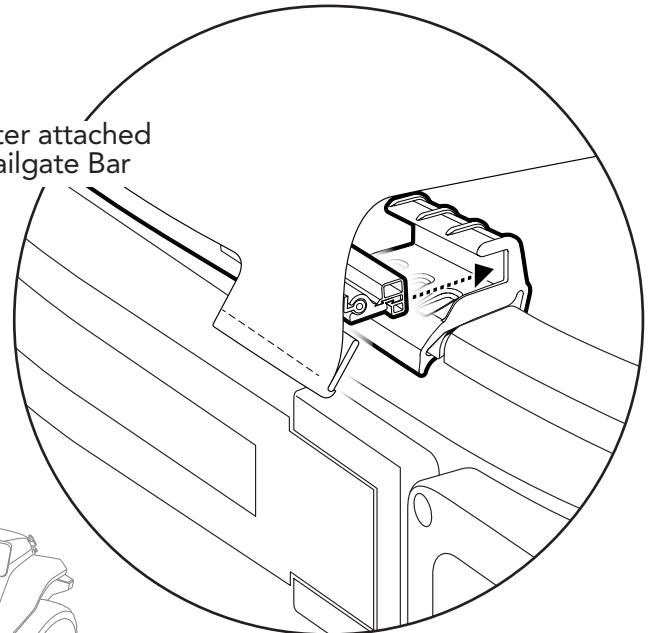
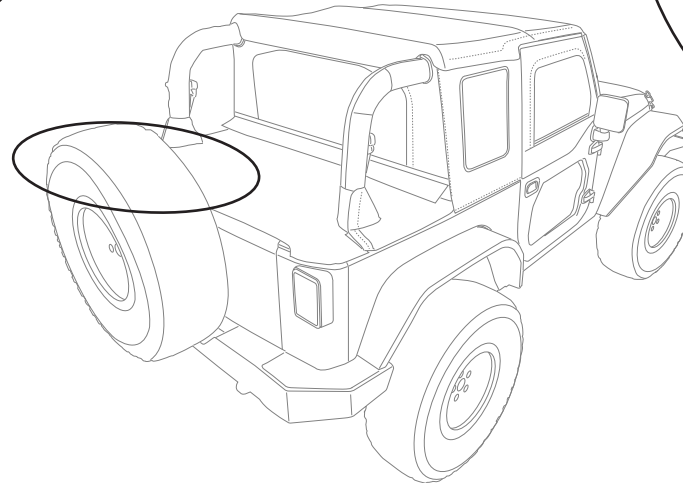

Duster attached to Tailgate Bar



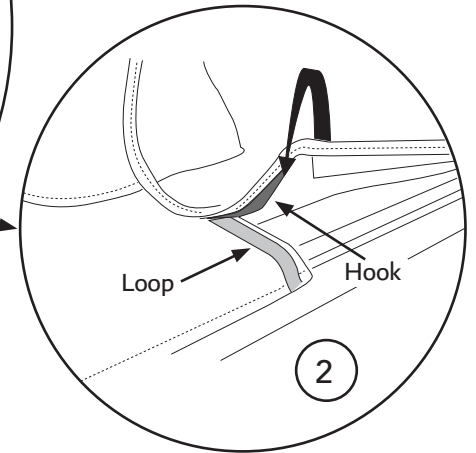
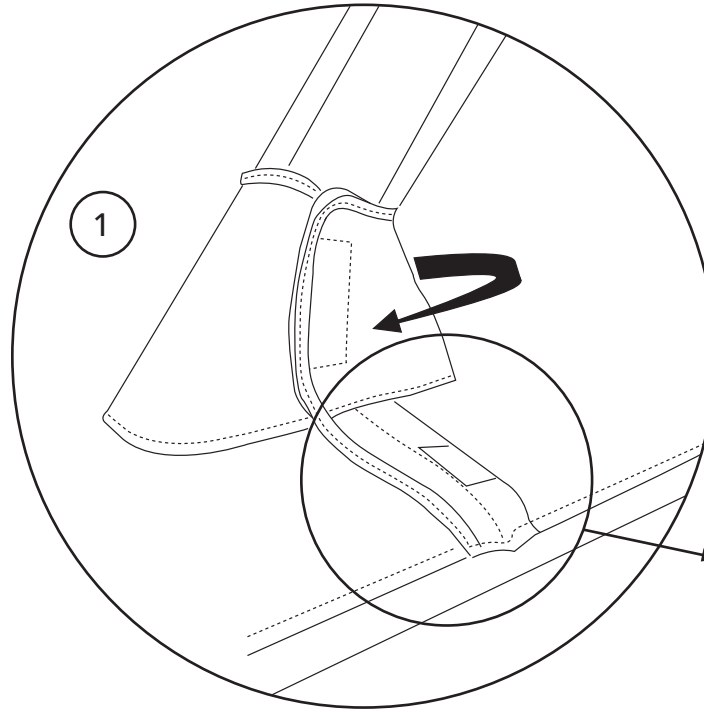
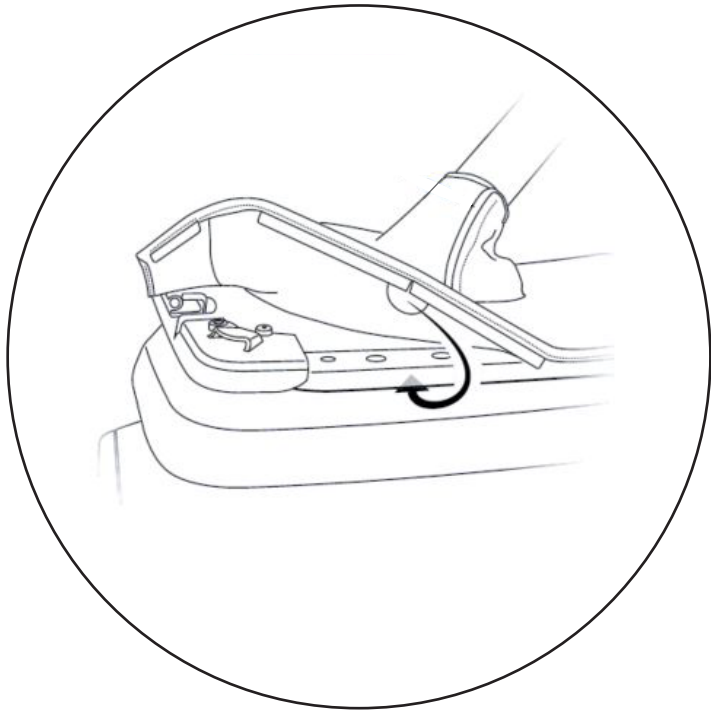

Tuck the plastic tabs along the left and right edges of the Duster underneath the Jeep belt rail, working from back to front. Make sure to tuck the straight tabs as well as the semi-circular tabs under the belt rail.

Tuck all side plastic tabs under the belt rail, from back to front, and then tuck the plastic tabs at the rear corners under the belt rail.

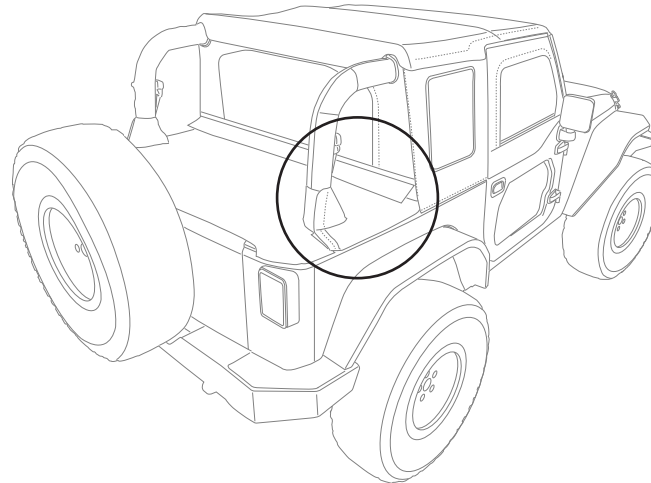

- 1 Wrap the hook-&-loop sleeves around the sport bar downtubes, and attach hook-&-loop strips together snugly.
- 2 Press the Hook and Loop together along the side of the Duster cover.

Repeat on left side of vehicle.

Tuck the plastic strip along the bottom edge of the Right Side Panel under the Jeep belt rail, by rolling it up underneath the belt rail, beginning at the rear, and working your way forward.

**NOTE:** Make sure you tuck the tab on the front edge of the Duster under the bottom edge of the Side Panel.

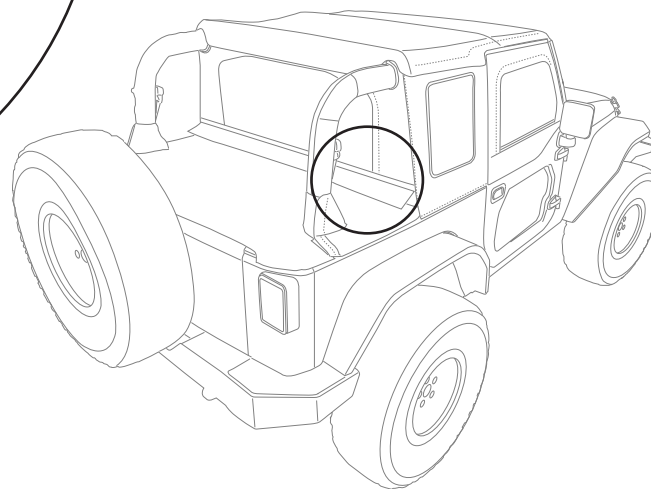
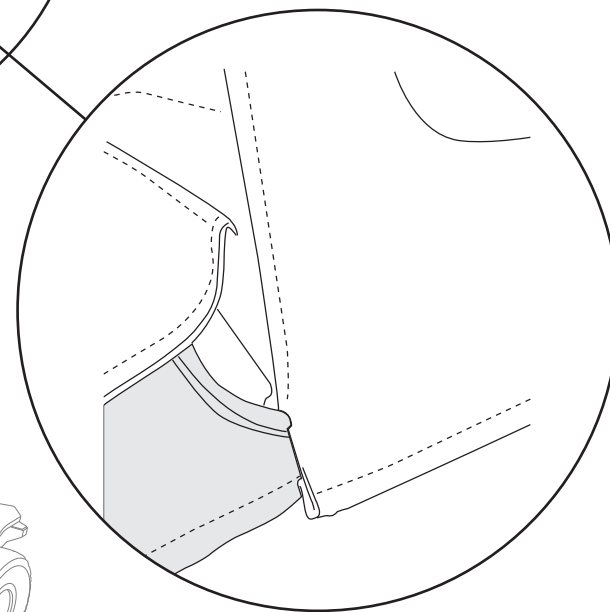
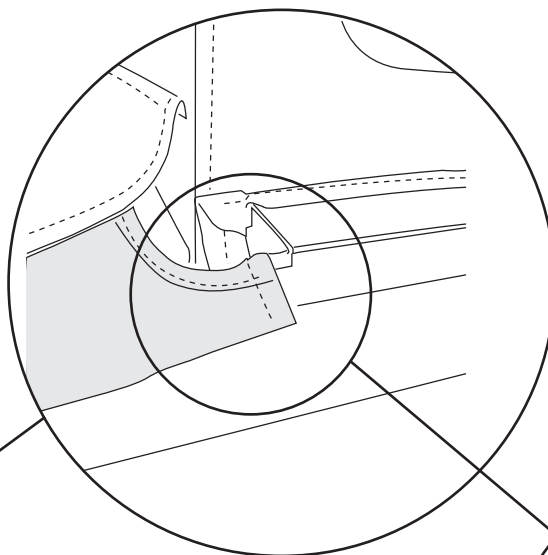
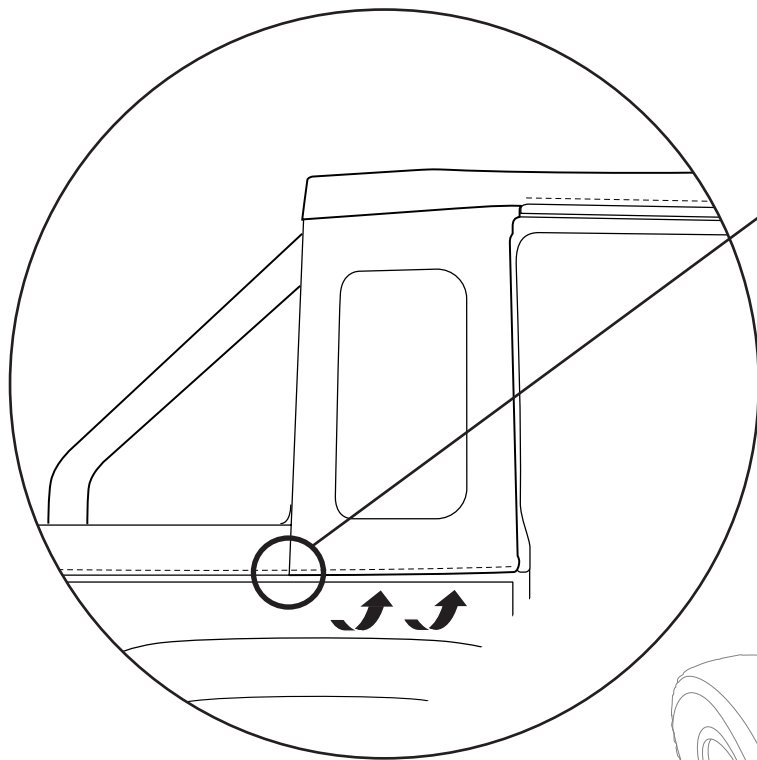

Repeat these steps on the left side of the vehicle.

1

Secure the Hook and Loop flaps along the top of the Windjammer that go over and under the sport bar.

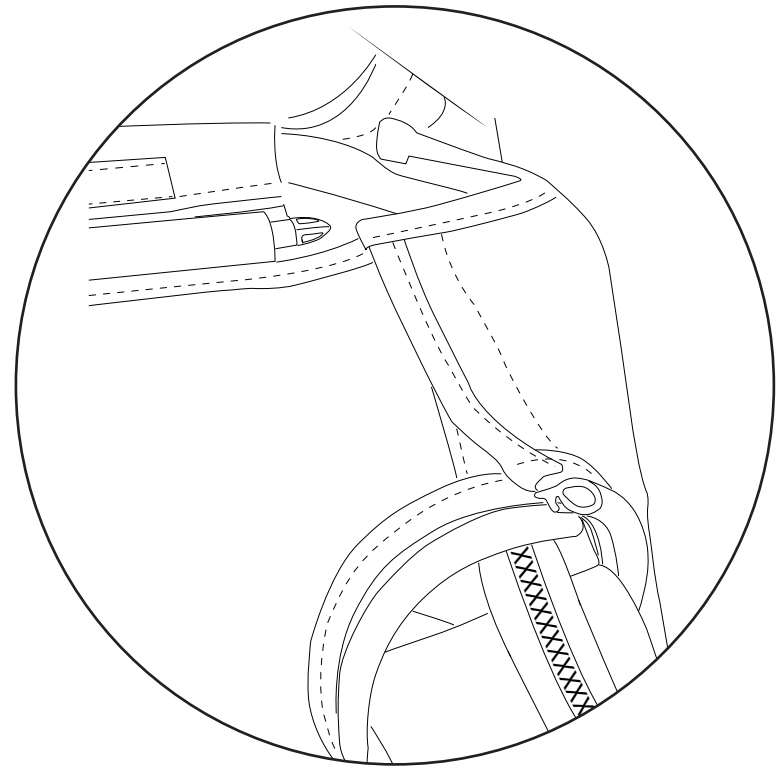
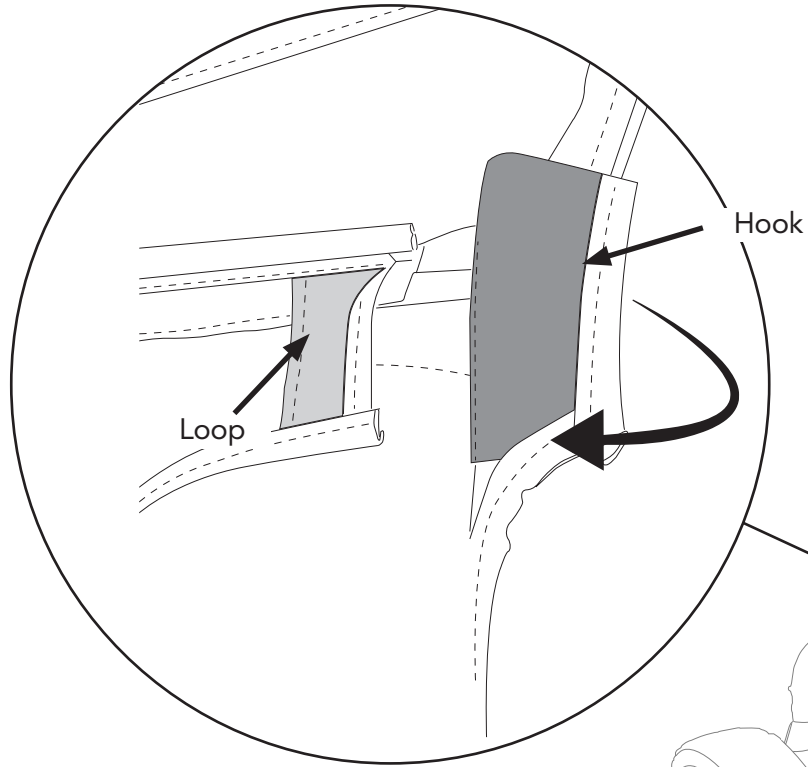

Repeat these steps on the left side of the vehicle.

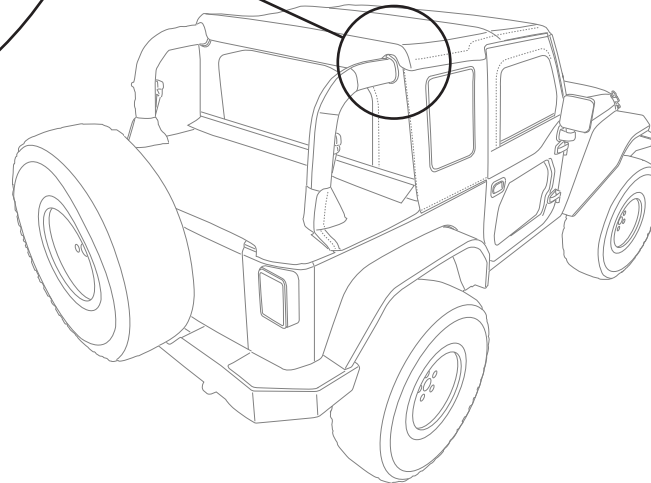

Secure the Hook and Loop along the side edge of the Top to the top edge of the Windjammer.

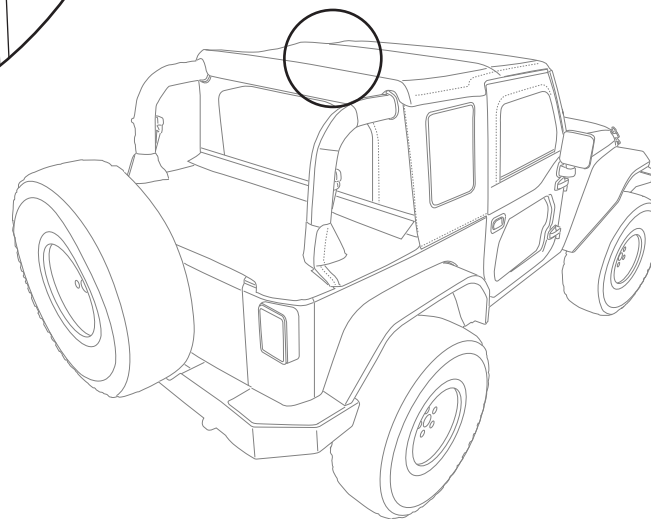
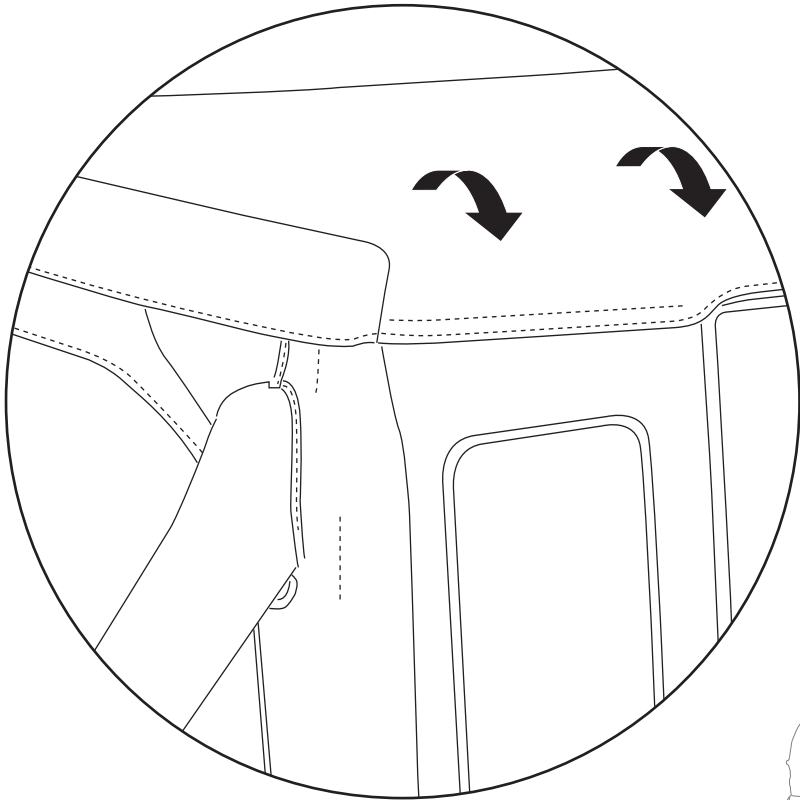



## Care and Maintenance of your Bestop Product

Your Bestop product is made of the finest materials available. To keep it looking new and for the maximum possible wear, it will need periodic cleaning and maintenance.

**Fabric:** The fabric should be washed often using soap, warm water and a soft bristle brush. Rinse with clear water to remove all traces of soap. Bestop recommends using Bestop Cleaner (part no. 11201-00) and Bestop Protectant (part no. 11202-00) for Vinyl fabric and Bestop Twill Protectant (part no. 11207-00) for Twill fabric. Bestop Cleaner and Bestop protectant are specially formulated to provide a total cleaning and protection system. Bestop Cleaner safely removes the toughest stains, will not harm vehicle finishes, is biodegradable and environmentally friendly. Bestop Protectant protects against UV-fading, cracking and hardening, and repels dust, grease, dirt and mildew.

**Windows:** Keep windows clean to avoid scratching. DO NOT use a brush on the windows! Wash with a water-soaked cloth or sponge and a mild dishwashing detergent. Bestop recommends Bestop Vinyl Window Cleaner (part no. 11203-00), which safely cleans and protects vinyl windows and helps prevent UV damage. NEVER WIPE THE WINDOWS WHEN THEY ARE DRY. Be careful when cleaning snow or frost from the vinyl windows since they are easily scratched and may crack at low temperatures. DO NOT roll the sides or rear window in cold weather. The windows become stiff and will crack. Cracks caused by misuse in cold temperatures are not covered under warranty.

**Water:** Seeping through at the seams may be stopped by applying 3-M Scotchgard® on the inside of the seams.

**Snaps:** Keep snaps cleaned and lubricated with silicone to help prevent snaps from sticking to the studs. If a snap does become stuck to a stud, use a screwdriver and GENTLY pry apart to prevent permanent damage to the snap or the top fabric.

**Zippers:** Keeping zippers cleaned and lubricated with Bestop's Zipper Cleaner (part no. 11206-00) will help prevent damage and keep the zippers in smooth working condition. If a zipper opens behind the slider, the slider may have been spread apart. This problem can usually be repaired by using an ordinary pair of pliers to bring the sides back into parallel. Return slider to the end of the zipper in the normal Open position. Squeeze lightly at first and test the zipper. If the zipper continues to remain open squeeze more firmly with the pliers and try the zipper again. Repeat this procedure until the zipper operates correctly.

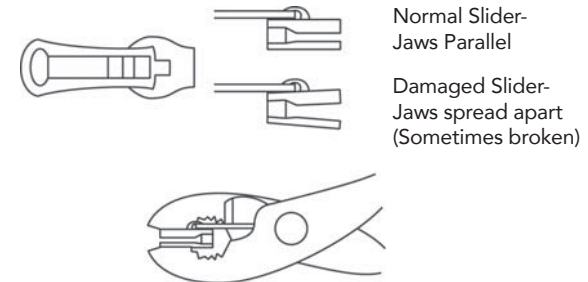

**For Bestop Warranty Information, Please go to;**  
<https://www.bestop.com/help/warranty-information/>

