



Installation Instructions

Factory Style Bow Kit

Vehicle Application:

- Jeep Wrangler Unlimited
2004 – 2006
Part Number: 55003

www.Bestop.com - We're here to help! Visit our web site and click on "[Ask a Question](#)". Click here for more [Jeep® Accessories by Bestop](#).

INSTALLATION TIME	SKILL LEVEL		
 2 Hours	 2 - Moderately Easy		
TOOLS			
 1/8" Bit	 #1, #2 & #3	 T30 and T40	

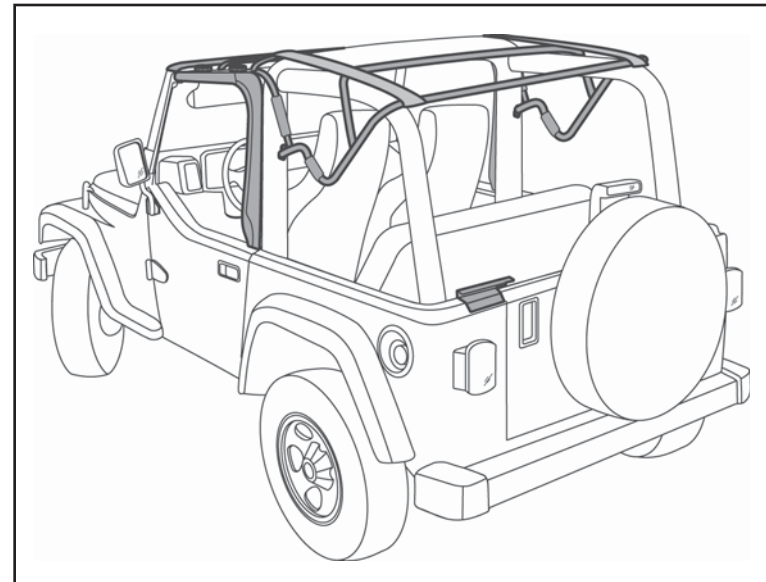

! WARNING This product is designed primarily to enhance the appearance of the vehicle. Do not rely in any way on the components of this product to protect against injury or death in the event of an accident. Never operate the vehicle in excess of manufacturer's specifications.

WEAR SEAT BELTS AT ALL TIMES

Read and follow, precisely, all installation instructions provided when installing product. Failure to do so may result in a poor fit and could place occupants of the vehicle in a potentially dangerous situation.

Bow Kit Installation Instructions

Parts List and Hardware Identification

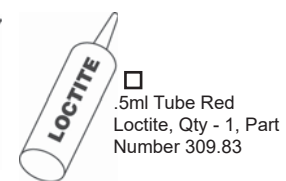
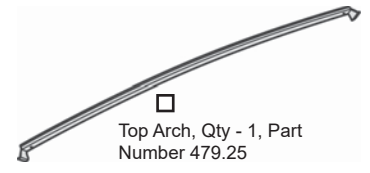
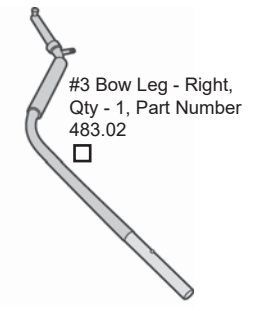
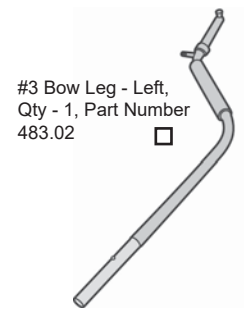
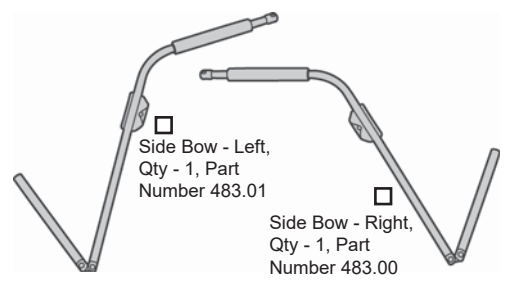
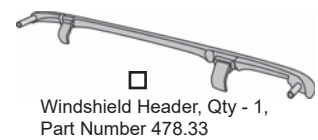
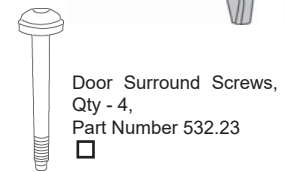
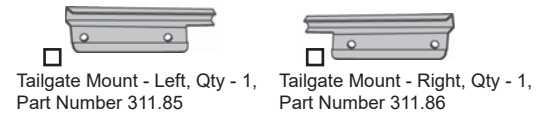
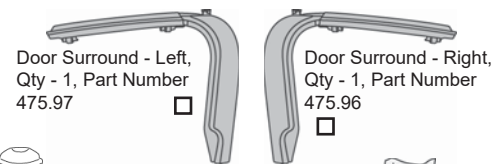
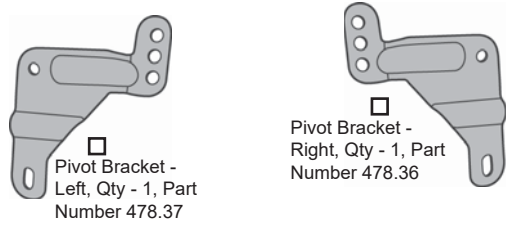
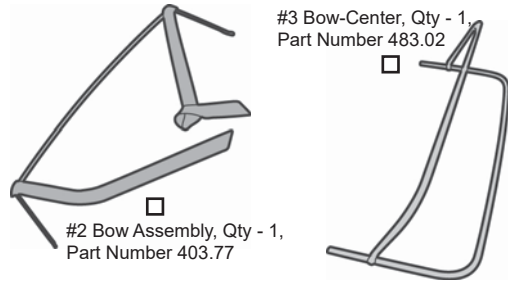

		#8 x 1/2" Pan Head Washer Screw - Black, Qty - 14 Part Number 200.48
		#8 x 1/2" Self Drilling Screw, Qty - 2, Part Number 312.09
		Pivot Knuckle Screw, Qty - 2, Part Number 308.65
		Pivot Bracket Bolt, Qty - 4, Part Number 308.64
		M5 x 30 Machine Screw, Qty - 2, Part Number 308.87
		#12 x 3/8" Tapping Screw, Qty - 4, Part Number 309.73
		Bushing, Qty - 4, Part Number 473.40
		#8 x 5/8" Tapping Screw, Qty - 8, Part Number 278.13
		M5 Lock Nut, Qty - 2, Part Number 308.62
		Oval Head Screw, Qty - 2, Part Number 276.56

Bow Kit Installation Instructions

1 Orient Tailgate Mounts

Locate the left and right Tailgate Mounts. Place the holes in the mounts over the dimples in the vehicle body. Mark the hole locations.

If you already have holes that line up, go to Step 3.

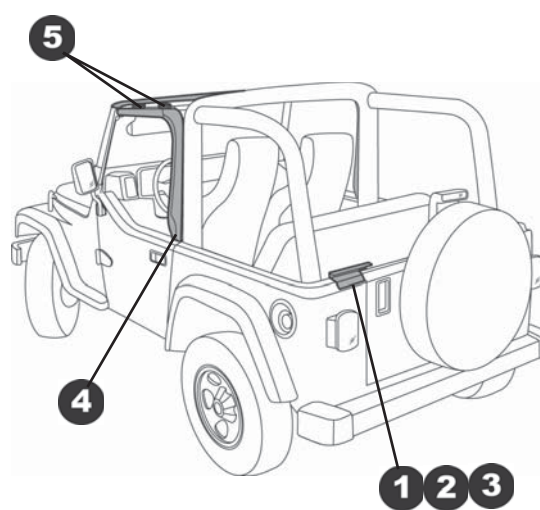
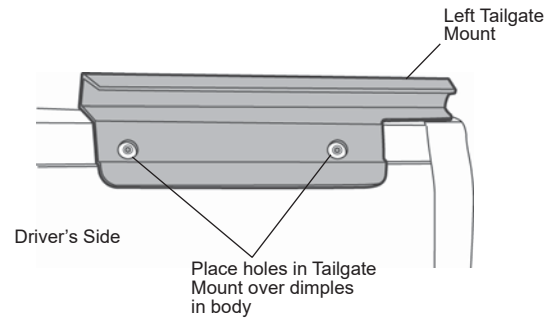

4 Install Door Surrounds

If your vehicle has molded seals on the belt rail, remove them by pulling up on the plastic rivet.

Locate the left and right Door Surrounds. Insert the pin in the bottom of the Door Surround into the hole in the belt rail behind the door.

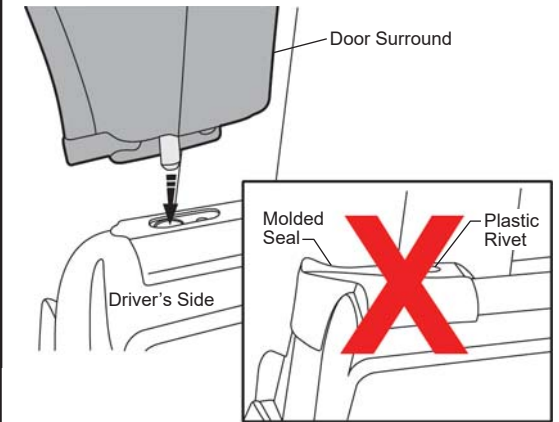

2 Drill Holes

Drill a 1/8" hole at the marked locations. Deburr the holes and seal the edges of the holes with Silicone Sealant.

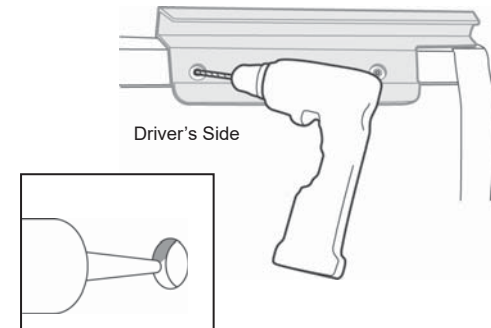

3 Install Tailgate Mounts

Install the Tailgate Mounts with two #8 x 1/2" Pan Head Washer Screws for each mount.

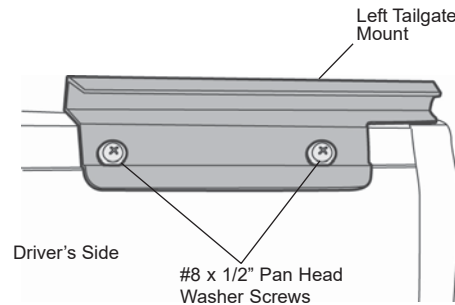

5 Install Door Surround Screws

Press the channels along the top of the Door Surround around the horizontal sport bar, above the door opening. Insert two Screws into the Door Surround and tighten to 55 in/lbs (4.5 ft/lbs).

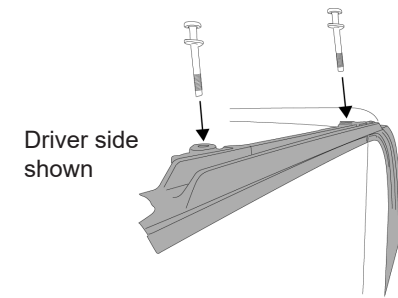

Bow Kit Installation Instructions

6 Mount Pivot Brackets on Sport Bars

Unzip the vertical padded cover over the sport bar and pull the pad away from the bar to expose the bracket location holes. Orient the Pivot Brackets over the existing holes in the sport bar and install them with the Pivot Bracket Bolts (two bolts per bracket). Zip the padded cover closed.

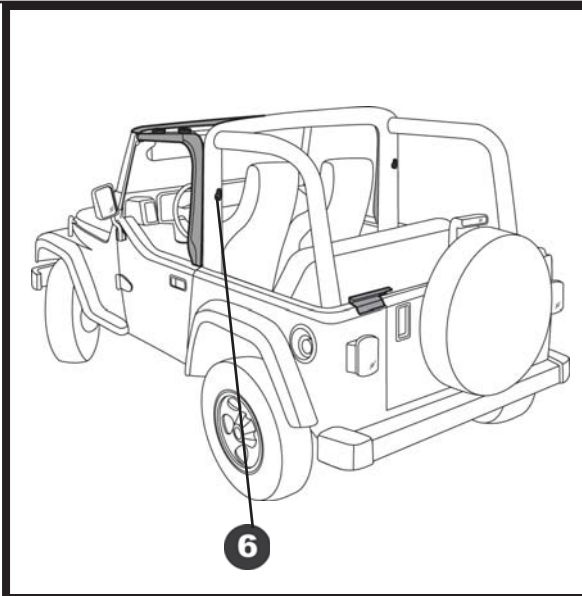
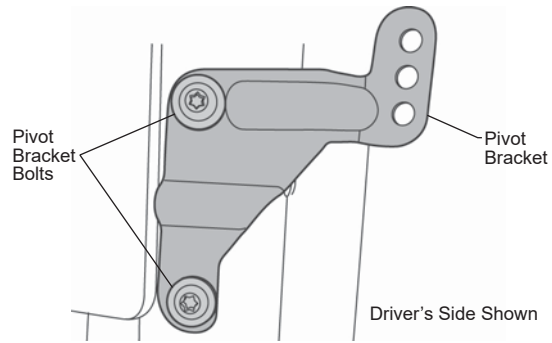

9 Assemble #2 Bow to Header / Side Bow Assembly

Turn the assembly over and place the #2 Bow on it so it rests on top of the curve of the Side Bows. Secure the #2 Bow to the assembly with an M5 x 50mm x 2" Screw, two (2) Bushings and an M5 Lock Nut.

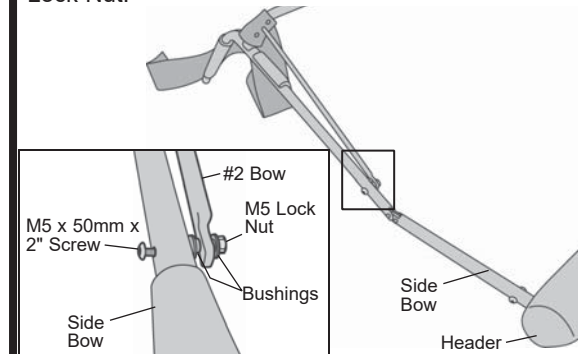

7 Assemble #3 Bow

Orient the #3 Bow Legs to the #3 Bow-Center with the knobs in the pivot knuckles toward the inside. Install a #8 Self-Tapping Screw in each leg.

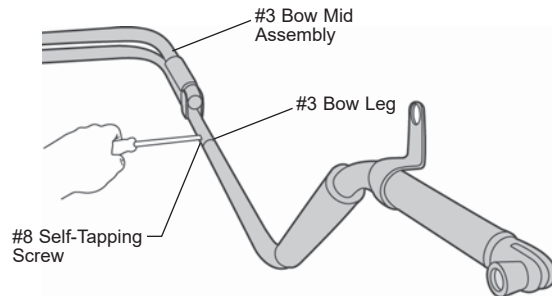

8 Assemble Side Bows to Header

Orient the Side Bows with the holes in the pivot knuckles toward the outside. Slide the other end over the section of tube and into the header. Install the #12 x 3/8" Tapping Screws, one on each side of the bow, on each side of the header (4 screws). Place a drop of Loctite on the threads of each screw before installing.

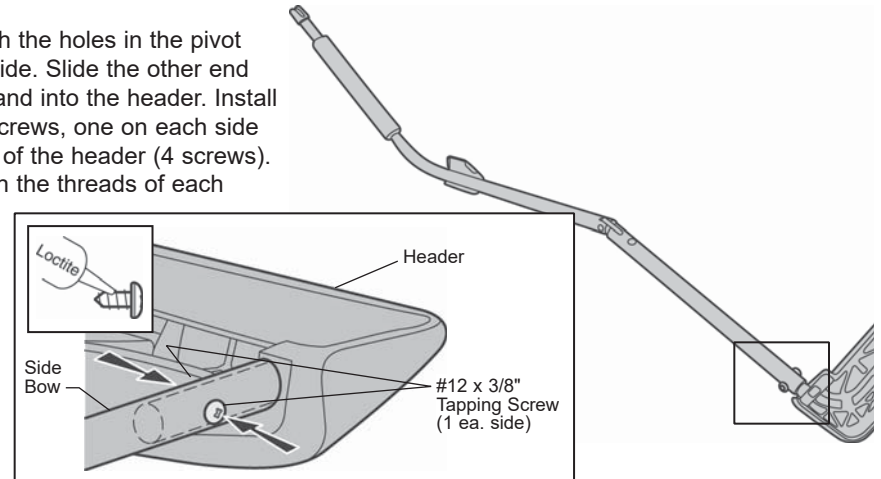

Bow Kit Installation Instructions

10 Install #3 Bow Assembly

To install the #3 Bow to the Pivot Bracket, pull out on the knob on the pivot knuckle and slide the slot in the knuckle over the Pivot Bracket. When the spring pin lines up with the bottom hole in the bracket release the knob. **If you are installing a new soft top, attach the bow to the bottom hole. You can move the knuckle to the an upper hole to tighten the top.**

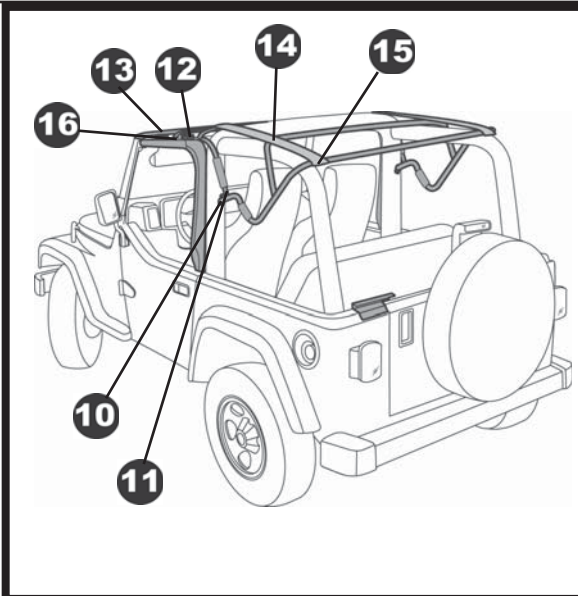
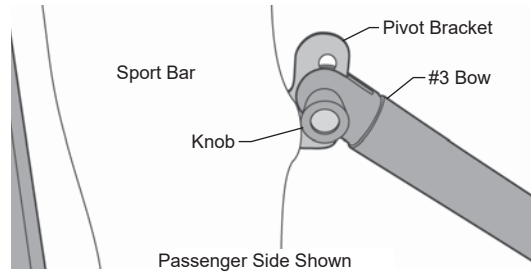

13 Secure Header to Windshield

Raise the Bow Assembly and latch the Header to the windshield.

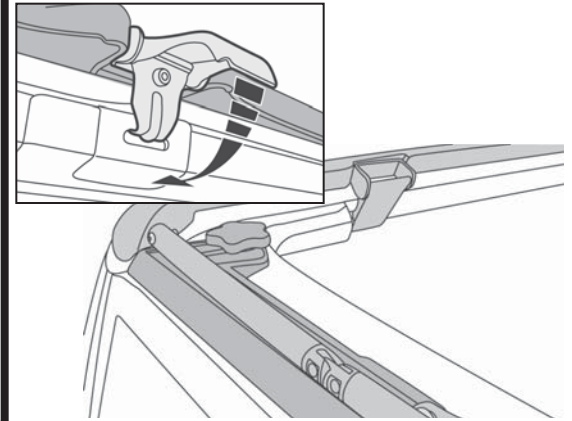

11 Install Header/#2 Bow Assembly

Use two (2) Pivot Knuckle Bolts to mount the Header/#2 Bow Assembly to the tab on the #3 Bow.

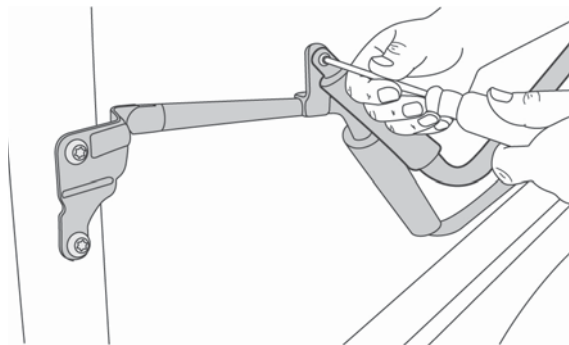

12 Secure Side Bows to Door Surrounds

Locate the Plunger Block mounted to each of the Door Surrounds and the Locking Block on each of the Side Bows. Secure the Locking Blocks into the Plunger Blocks.

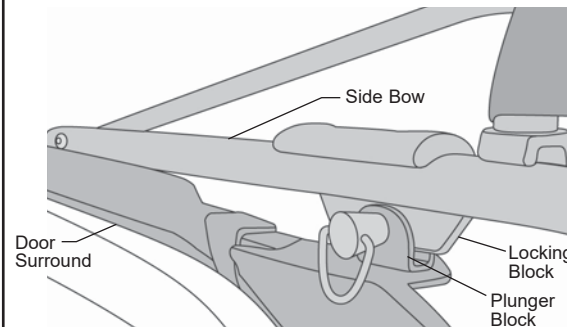

14 Secure Stay Pad

Pull the fabric stay pad on the #2 Bow straight back to the #2.5 Bow (attached to the #2 Bow). Do not twist the pad. Use two (2) #8 x 1/2" Phillips Head Washer Screws to secure the pad to the corner of the bow.

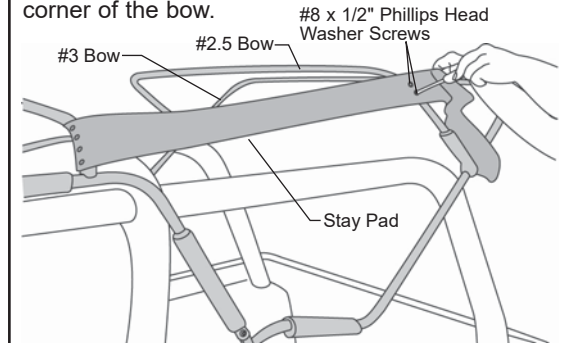

Bow Kit Installation Instructions

15 Secure Stay Pad

Pull the tail of the fabric stay pad straight back to the #3 Bow. Do not twist the pad. Use three (3) #8 x 1/2" Phillips Head Washer Screws to secure the pad to the corner of the bow.

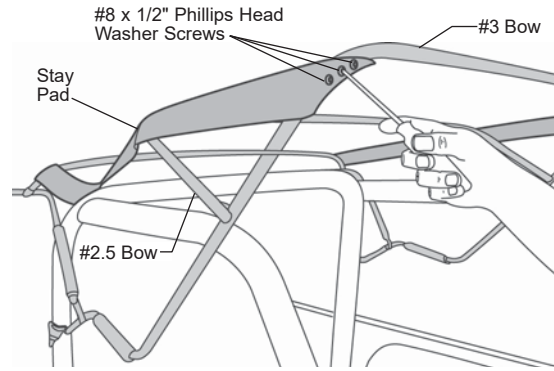

16 Install Top Arch

Insert one end of the top arch in to the slot in the middle of one of the Door Surrounds. Push the other end inward to flex the bow and insert it into the slot on the other side of the vehicle.

NOTE

Remove adhesive paper from Top Arch before installing.

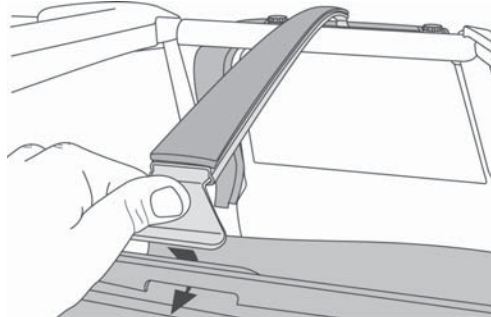

LIMITED WARRANTY

We warrant our product to be free from defects in material and workmanship, for the terms specified below, provided there has been normal use and proper maintenance. This warranty applies to the original purchaser only. All remedies under this warranty are limited to the repair or replacement of any item or items found by the factory to be defective within the time period specified. If you have a warranty claim, first you must call our factory at the number below for instructions. You must retain proof of purchase and submit a copy with any items returned for warranty work. Upon completion of warranty work, if any, we will return the repaired or replaced item or items to you freight prepaid. Damage to our products caused by accidents, fire, vandalism, negligence, misinstallation, misuse, Acts of God, or by defective parts not manufactured by us, is not covered under this warranty.

THE WARRANTY TIME PERIOD IS AS FOLLOWS FOR REPLACE-A-TOP™, SAILCLOTH REPLACE-A-TOP™, SUPERTOP®, SUPERTOP® REPLACEMENT SKINS, SUNRIDER®, AND TIGERTOP®: TWO YEARS FROM DATE OF PURCHASE.

THE WARRANTY TIME PERIOD IS AS FOLLOWS FOR ALL OTHER "SOFT GOODS" MANUFACTURED BY OUR COMPANY (USING PRIMARILY VINYL, PLASTICS, AND/OR FOAM): ONE YEAR FROM DATE OF PURCHASE.

THE WARRANTY TIME PERIOD IS AS FOLLOWS FOR ALL OTHER "HARD GOODS" MANUFACTURED BY OUR COMPANY (USING PRIMARILY METALS, PLASTICS, AND/OR FIBERGLASS): ONE YEAR FROM DATE OF PURCHASE.

ANY IMPLIED WARRANTIES OF MERCHANTABILITY AND/OR FITNESS FOR A PARTICULAR PURPOSE CREATED HEREBY ARE LIMITED IN DURATION TO THE SAME DURATION AND SCOPE AS THE EXPRESS WRITTEN WARRANTY. OUR COMPANY SHALL NOT BE LIABLE FOR ANY INCIDENTAL OR CONSEQUENTIAL DAMAGE.

Some states do not allow limitations on how long an implied warranty lasts, or the exclusion or limitation of incidental or consequential damages, so the above limitations or exclusions may not apply to you. This warranty gives you specific legal rights, and you may also have other rights which vary from state to state.



For further information or request for warranty work, please contact:
Bestop Inc. Customer Service
Toll-Free: (800)845-3567
E-mail: csbestop@Bestop.com
Website: www.Bestop.com