



Installation Instructions

PowerBoard®

Automatic Retracting Running Board

Vehicle Application

• Chevy Silverado/GMC Sierra Extended Cab Diesel 2011 and newer
Part Number: 75147-15

• Chevy Silverado/GMC Sierra Crew Cab Diesel 2011 and newer
Part Number: 75146-15

www.bestop.com - We're here to help! Visit our web site and click on "Ask a Question". Click here for more [Truck Accessories by Bestop](#).

INSTALLATION TIME	SKILL LEVEL
4 Hours	4 - Difficult

TOOLS				
 Tape Measure	 Flat-Head Screwdriver	 Torque Wrench	 Power Drill	 Ratchet
9/32" Drill Bit				
 Extension	 Wrench 13 mm	 Socket 10 mm, 13 mm	 Allen Wrench 5 mm	 Crimp Tool
 Wire Cutters	 Wire Stripper	 Electrical Tape	 Silicone Sealant	 Safety Glasses



! WARNING The manufacturer strongly recommends that this product be professionally installed.

! WARNING Failure to carefully follow the electrical installation steps could result in severe electrical shock which could harm the installer and/or damage the vehicle.

! WARNING Do not rely in any way on the components of this product to protect against injury or death in the event of an accident. Never operate the vehicle in excess of manufacturer's specifications.

WEAR SEAT BELTS AT ALL TIMES

Read and follow, precisely, all installation instructions provided when installing product. Failure to do so may result in a poor fit and could place occupants of the vehicle in a potentially dangerous situation.

PowerBoard® – Installation Instructions

Parts List and Hardware Identification

Running Board Assembly, Qty - 2
72" - Part Number 514.08
79" - Part Number 514.07

Adaptor Plate, Part Number 487.18, Qty - 2

Threaded Clamping Plate, Part Number 460.97, Qty - 2

Blue Controller, Part Number 496.11, Qty - 1

Brake Cable Ring, Part Number 460.93, Qty - 1, (Silverado and Sierra Heavy Duty Only)

Motor (for use with Blue Controller), Part Number 496.12, Qty - 2

Wiring Harness, Part Number 487.11, Qty - 1

Parking Brake Cable Guide, Part Number 470.08, Qty - 1

Posi-Tap, Part Number 470.03, Qty - 4

Wire Installation Tube, Part Number 470.01, Qty - 1

Left Front Idler Linkage, Part Number 486.97, Qty - 1

Right Front Idler Linkage, Part Number 486.96, Qty - 1

Right Rear Motor Linkage, Part Number 486.98, Qty - 1

Left Rear Motor Linkage, Part Number 486.99, Qty - 1

Replacement Brake Cable Guide, Part Number 460.92, Qty - 1 (Silverado and Sierra Heavy Duty Only)

Light, Part Number 470.15, Qty - 4

Mounting Insert, Part Number 487.19, Qty - 2

Spacer, Part Number 470.09, Qty - 10

7" Cable Ties, Part Number 460.99, Qty - 25

11" Cable Ties, Part Number 470.02, Qty - 2

M6-1.0 x 20 Socket Cap Screw, Part Number 470.00, Qty - 8

M6-1.0 x 35 Socket Cap Screw, Part Number 460.95, Qty - 6

M8-1.0 x 20 Socket Cap Screw, Part Number 502.99, Qty - 2

M8-1.25 x 30 Flange Hex Bolt, Part Number 474.85, Qty - 11

M8 Flat Washer, Part Number 484.93, Qty - 2

M8 Fender Washer, Part Number 470.07, Qty - 2

Rubber Grommet, Part Number 470.04, Qty - 1

Nylock Nut, Part Number 470.06, Qty - 1

M6 Flat Washer, Part Number 481.96, Qty - 6

M8 U-Nut, Part Number 460.98, Qty - 4

PowerBoard® – Installation Instructions

2015 – Current Only

1 Cap Removal

Remove the two (2) screws that hold the protective cap in place. Set aside to be reused later.

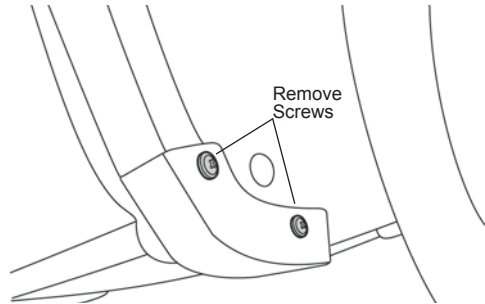

2 Remove Clip

Gently pull back on the clip that holds the cap on to the sheet metal. Pull toward the rear to release it from the sheet metal.

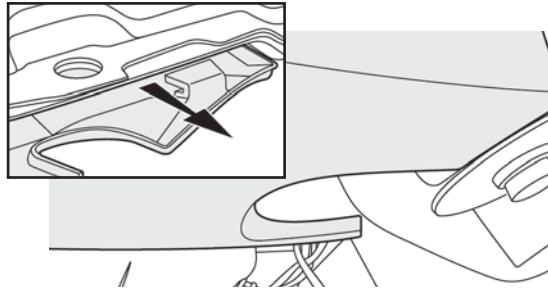

3 Cut Out Template

Use scissors to cut out the template that is included on the last page of the installation along the dotted lines.

NOTE Passenger Side shown. Flip over to use on Driver's Side.

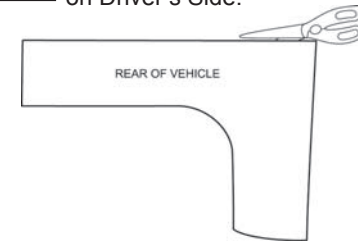

2015 – Current Only

4 Use Template to Mark Cap

Hold Template up to cap and mark the cap along the edge of the template.

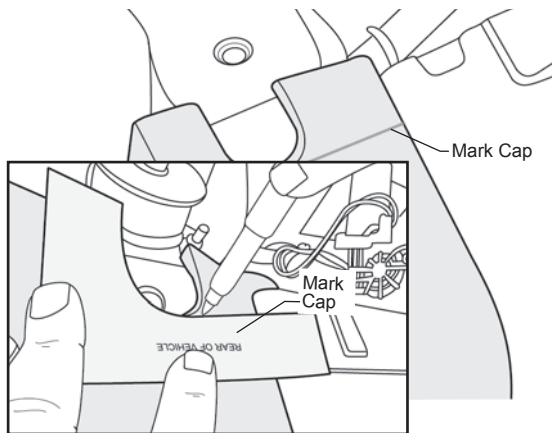

5 Trim Cap

Pull down on the end cap and use plastic nibblers or a utility knife to trim along the line marked in Step 4.

NOTE Cap must be trimmed while on the vehicle. DO NOT attempt to use a saw.

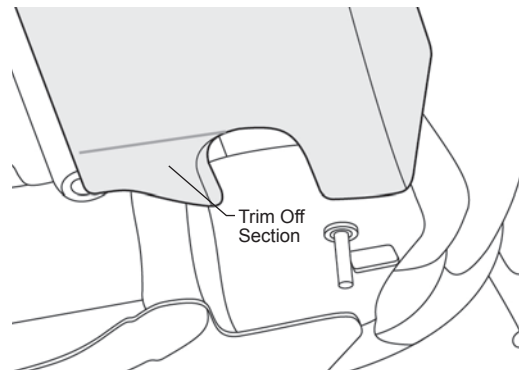

6 Reinstall Screws

Reinstall the screws removed in Step 1.

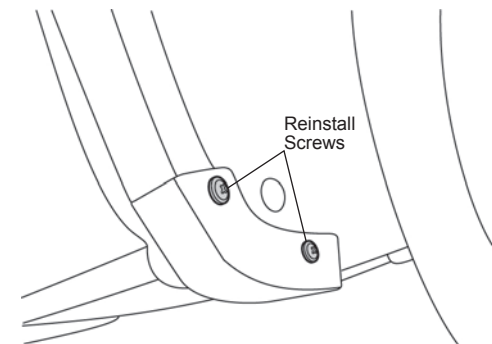

PowerBoard® – Installation Instructions

All Vehicles

NOTE Steps 1 and 2 are for HD 2500 and 3500 only. For all other vehicles skip to Step 3.

Short Bed
Step 1 only.

Long Bed
Steps 1 and 2.

1 Heavy Duty Trucks Only Install Replacement Brake Cable Guides

Remove the forward brake cable guide and replace with the Replacement Brake Cable Guide.

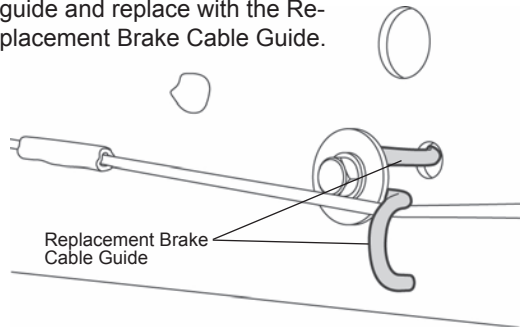

2 Heavy Duty Long Bed Only Install Brake Cable Ring and Parking Brake Cable Guide

Install Brake Cable Ring in rear of middle body mount. Install new Parking Brake Cable Guide in existing frame hole as shown.

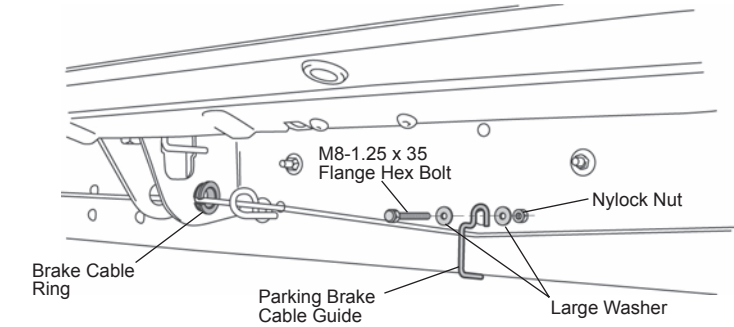

3 Install Rear Motor Linkage

Remove the plastic cap and install a U-Nut in fourth sheet metal tab / hole from front. Mount driver side Rear Motor Linkage to U-Nut so that the Arm will clear parking brake cable..

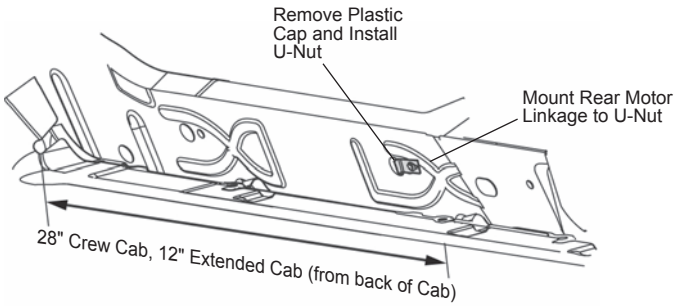

4 Install Driver Side Rear Linkage

Install Threaded Clamping Plate on top of pinch weld. Thread M8-1.0 x 20 Socket Cap Screw into clamping plate. Then install an M8-1.25 x 30 Flange Hex Bolt. **Finger tighten only.**

If it looks like the running board will touch the body see step 29 for adding shims.

Repeat Steps 3 and 4 to install the passenger side Linkages.

NOTE If there is a weld nut at this location, do not use the Threaded Clamping Plate.

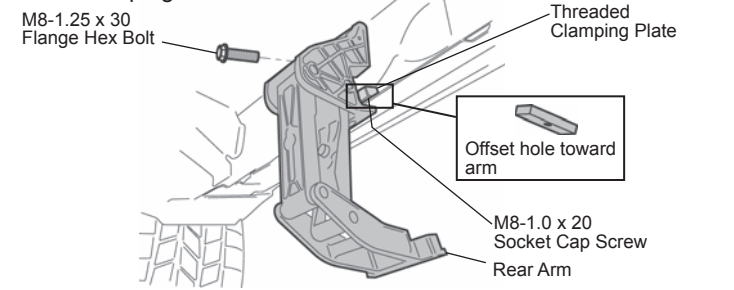

PowerBoard® – Installation Instructions

5 Install Front Idler Linkage

Locate the body rib in front of the plastic tank under the right side of the truck. Insert a M8-1.25 x 30mm Flange Hex Bolt through the large slot in the Adaptor Plate and thread it loosely into the large flat surface of a Mounting Insert. Put the Mounting Insert into the hole in the body rib and tighten the bolt with the insert angled so it bridges the hole. Leave the bolt loose enough so the adaptor can be moved up and down.

Remove the bolt in the body flange at the location that will line up with the front bottom hole in the link. If there is not a bolt push an M8 U-Nut over the hole.

Attach the Right Idler Linkage to the Adaptor plate with two M8-1.25 x 30mm Flange Hex Bolts. **Leave the bolts loose.**

Add Spacers between the bottom front hole in the linkage and the body flange until the linkage is flat against the body flange. The truck sheet metal that is sandwiched here will compress when the bolt is tightened so be sure to use enough spacers. Insert an M8-1.25 x 30mm Flange Hex Bolt with M8 Flat Washer into the hole and tighten making sure the linkage bottoms out on the spacers. If not add more spacers. **Alternately tighten all of the bolts.**

If it looks like the running board will touch the body see step 29 for adding shims.



CAUTION

Make sure to use an M8-1.25 x 30mm Hex Bolt and M8 Flat Washer in the bottom front hole. Use of a longer bolt here may cause the Linkage to break.

NOTE

Tightening the fasteners before cycling the step several times may create a bind, causing a squeaking sound and preventing the boards from retracting completely and evenly.



CAUTION

M8-1.25 x 30mm Hex Bolt, M8 Flat Washer, Spacers and M8 U-Nut

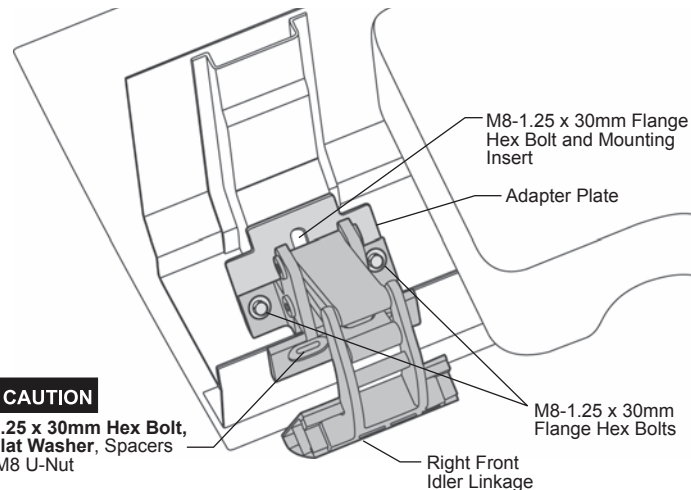

6 Install Controller and Wire Harness

Use the two (2) 11" Cable Ties to mount the Controller to the support arm next to the battery (behind the support arm on diesel engines).

Plug in the Wire Harness. Make sure that the locking tabs engage.

NOTE

On hybrid models mount the Controller on the driver's side.

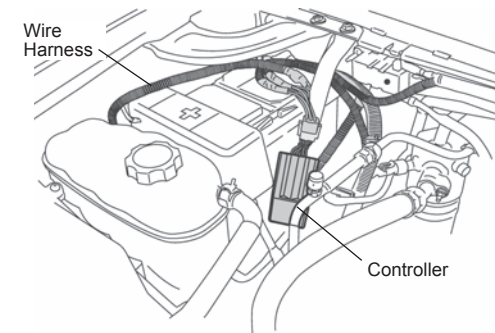

PowerBoard® – Installation Instructions

! WARNING Remove the fuse from the Wiring Harness.

7 Remove Fuse from Wiring Harness

Remove the fuse from the Wiring Harness. Failure to do so could result in severe electrical shock which could harm the installer and/or damage the vehicle.

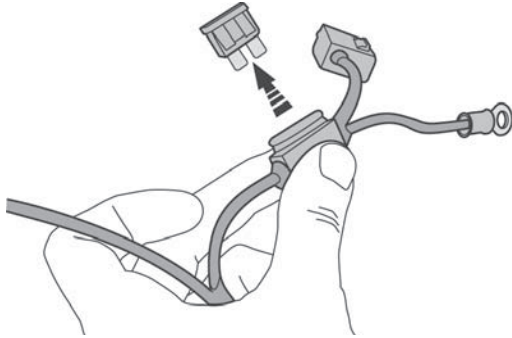

! CAUTION Do not ground wrench when engaged with nut.

8 Attach Leads

Attach power lead (RED wire) to positive pole on the battery.
Attach ground lead to negative battery pole.

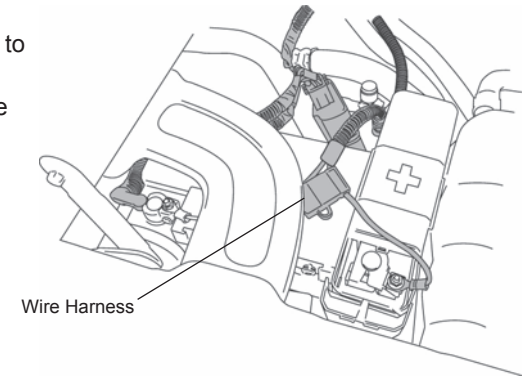

9 Route Wire Harness – Gas Engine

Route long end of wire harness above engine and down through drivers side wheel well. Cable tie harness to cowling clips on fire wall. Route short end down passengers side.

NOTE On hybrid models route the long end of the wire harness down the passenger wheel well and the short end down the driver's side.

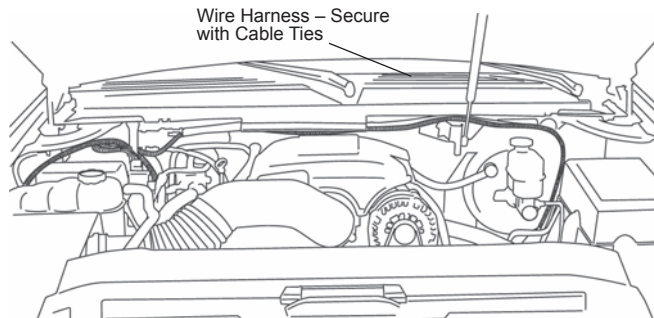

10 Route Wire Harness – Diesel Engine

Route long end of wire harness under intake and along factory engine harness to driver side wheel well. Route short end down passengers side.

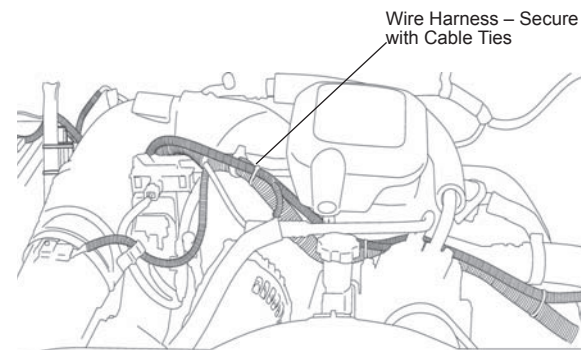

PowerBoard® – Installation Instructions

11 Install Wires – Driver’s Side

Puncture the grommet in the underside of the floor panel near the front door and thread the two wires from the Wiring Harness through the grommet.

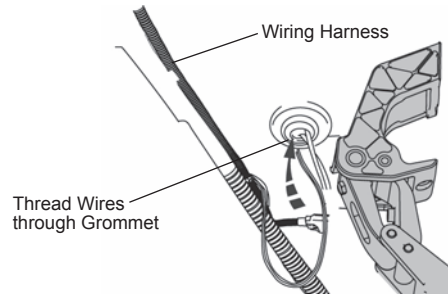

12 Remove Kick Plate – Driver’s Side

Use a flat screwdriver to pop off the threshold cover and remove the kick plate.

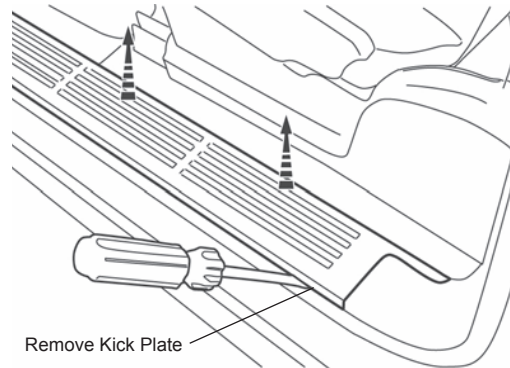

13 Route Wires – Driver’s Side

Pull up the carpet and thread both wires through the floor panel. Seal hole with silicone sealant and cover with tape so carpet does not stick to sealant.

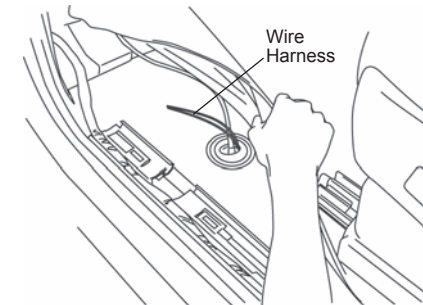

14 Install Wires – Passenger’s Side

Remove the kick plate, drill a 9/32" hole in the floor panel, from inside the vehicle, and install the Rubber Grommet from the parts kit. Then thread the wires from the harness through the Grommet.

Thread the wires through the floor panel and seal the hole with silicone sealant and cover with tape so carpet does not stick to sealant.

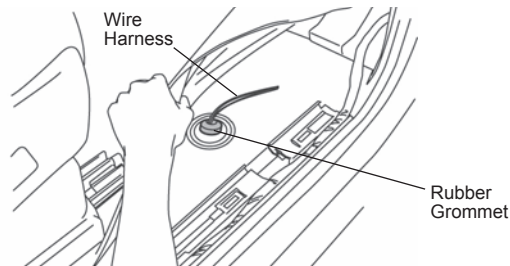

15 Connect Wires – Crew Cab Only

Remove the wire wrap and find LIGHT BLUE with BLACK STRIPE wire on the driver’s side. On the passenger side find GREEN with BLACK STRIPE wire. The wire should be located rear of the “T” junction where the wires cross under the front seat.

NOTE If you have an Extended Cab, these wires will not be used. Tape off the short white wire.

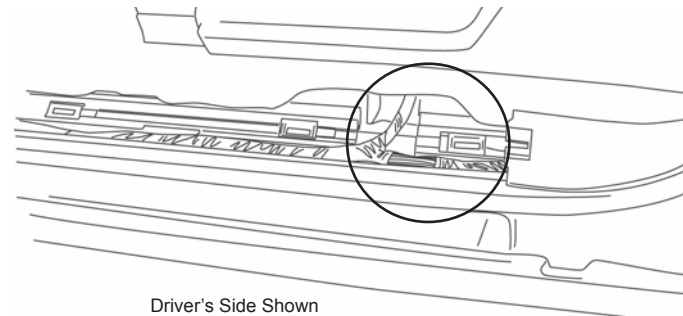

PowerBoard® – Installation Instructions

16 Connect Wires – Crew Cab Only

Use the Posi-Tap™ Connector to splice the shorter white trigger wire into the Light Blue or Green wire found in Step 15.

NOTE If you have an Extended Cab, these wires will not be used. Tape off the extra wires.

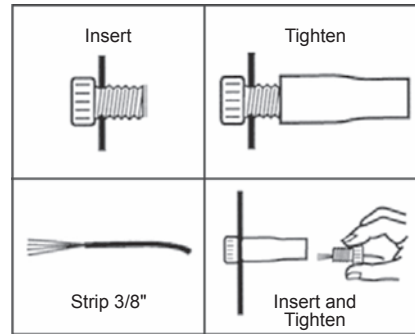
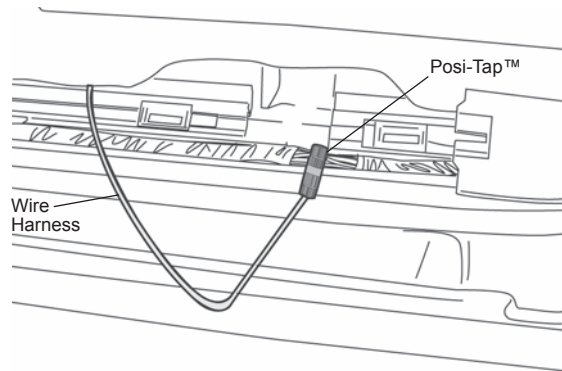

Posi-Tap™ Instructions

17 Locate Front Door Ajar Wires

Hybrid models go to Step 19.

Locate and inspect the Body Control Module above the brake pedal under the dashboard. The BCM is the only module with a pink connector. Check to see if the front door ajar signal wires are present in the pink connector: Grey/Black, Tan/White. If you do not see these wires, go to Step 20.

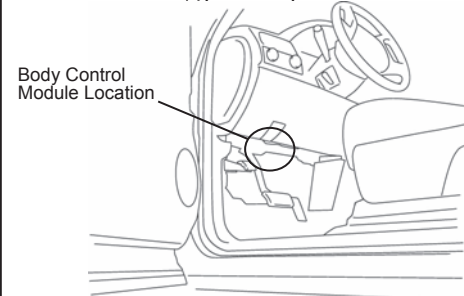

18 Locate Front Door Ajar Wires

Remove driver side kick panel and open the loom wrapped in grey tape to access the Grey / Black stripe wire. Behind the passenger side kick panel the loom wrapped in tape and heading to the door will have a Tan / White stripe wire. Connect PowerBoard® Green wire to the factory wires. Proceed to Step 26.

NOTE If you can not find the Grey / Black and Tan / White wires go to Step 21.

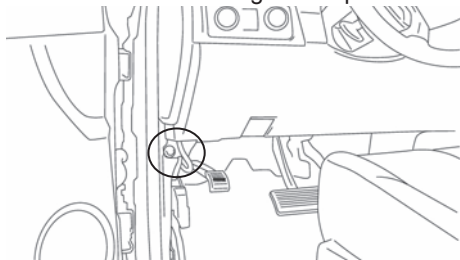

19 Remove Door Trim

Vehicles that do not have the front door ajar signal wires in the pink connector of the BCM or behind the kick panel must have the front door panels removed in order to access the front door ajar signal wires.

Remove the plastic trim on the door near the mirror attachment.

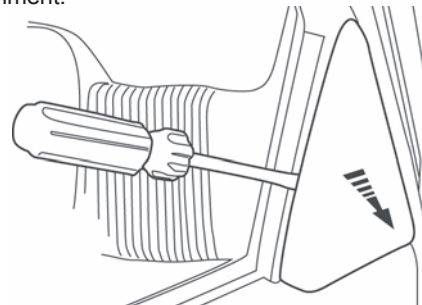

20 Remove Door Panel

Pry back tab on door lock to remove, then pry off plastic covers by handle and door latch. Remove the three (3) door bolts and then remove door panel by prying loose all panel fasteners.

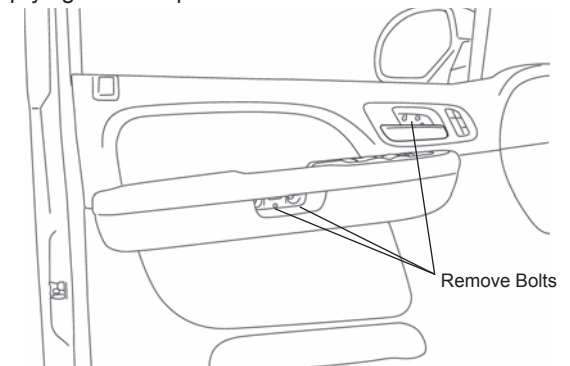

PowerBoard® – Installation Instructions

21 Thread Long Wire from Harness

Pull back the door weather guard, unbolt the speaker and unplug it.

Locate the plastic Wire Installation Tube in the parts kit. Thread the tube into the hole in the door, through the accordion between the door and the vehicle. Then thread the longer Green wire from the Wiring Harness through the tube into the door. Once the wire is in place, remove the tube from the door side.

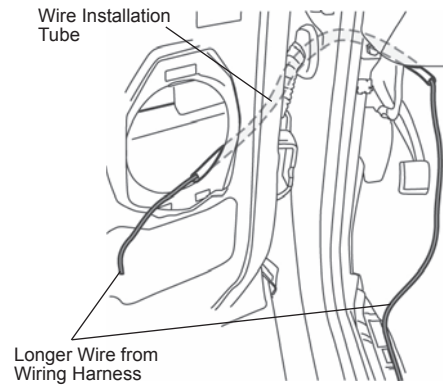

22 Route Connecting Wire in Door

Thread the longer Green wire from the Wiring Harness along the path of the Wiring Harness that goes to the switch plate in the door.

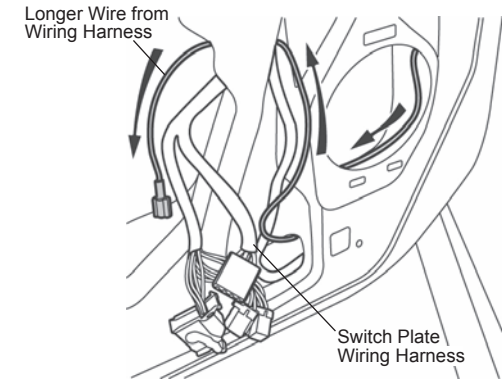

23 Connect Wires

Locate the brown plug and use the supplied Posi-Tap™ connector to splice into trigger wire.

Drivers side: Grey / Black wire

Passengers side: Tan / White wire

Reassemble door and replace plugs. Plugs must be replaced for PowerBoard® to operate.

NOTE Models may vary so check all wire bundles until you find the correct colored wire.

NOTE On Hybrid models the PowerBoard® trigger wire colors will not match factory wires because the wire harness is flipped.

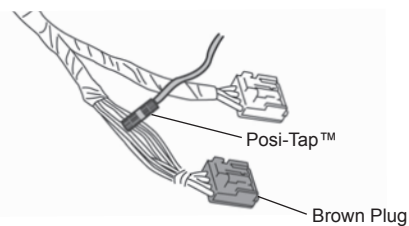

24 Install Lights

Clean the outboard surface of the of the Linkage below the bottom mounting bolt. Peel the adhesive liner off the back of the Light and firmly press it 1/8" below the mounting bolt. Plug the light into the connector with the black and orange wires in the wire harness. Repeat with the other three lights. Secure loose wires with Cable Ties.

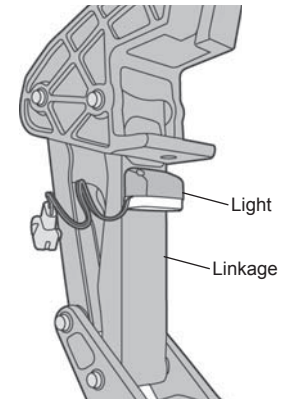

PowerBoard® – Installation Instructions

25 Install Running Boards

Mount the Steps to the linkages. Slide the mounting T-Nut into position. Install M6-1.0 x 20mm Socket Head Bolts to secure the boards. Use a 5mm Allen Wrench to tighten the bolts.

Make sure the board moves up and down freely by hand. If it binds, loosen the linkage to body attachment bolts and adjust the linkage position until the boards move freely. **Do not tighten the bolts at this time.**

NOTE *Tightening the fasteners before cycling the step several times may create a bind, causing a squeaking sound and preventing the boards from retracting completely and evenly.*

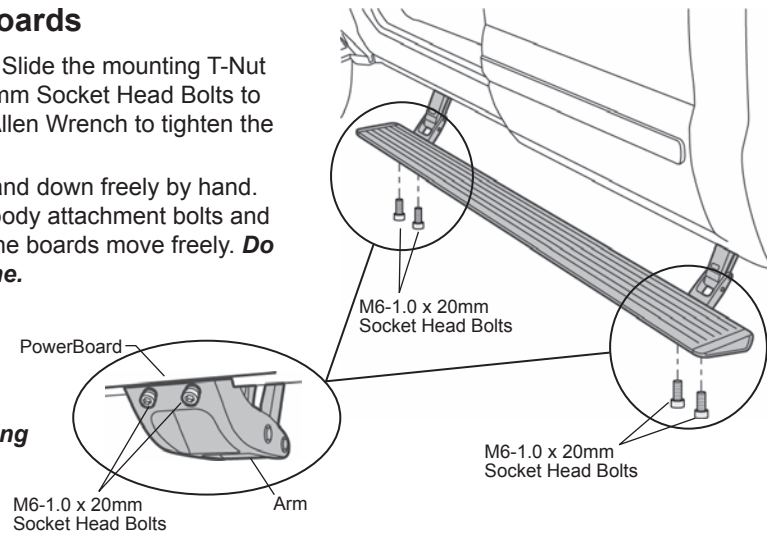

26 Install Motor

Slide Motor assembly onto drive shaft and mounting bosses of Motor Linkage assembly. Use three (3) M6-1.0 x 35mm Socket Cap Screws and M6 Flat Washers to secure Motor. Plug female connector into Motor. Wrap any exposed wires from the motor with electrical tape. Torque the screws to 5–7 ft. lbs. (6.78–9.49 Nm or 60-84 in. lbs.).

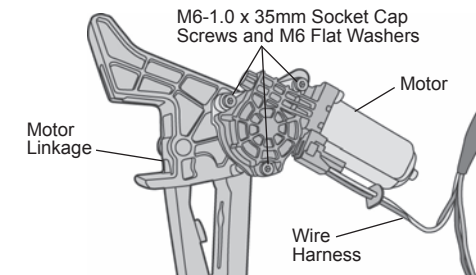

27 Reinstall Fuse

Reinstall the fuse in the harness.

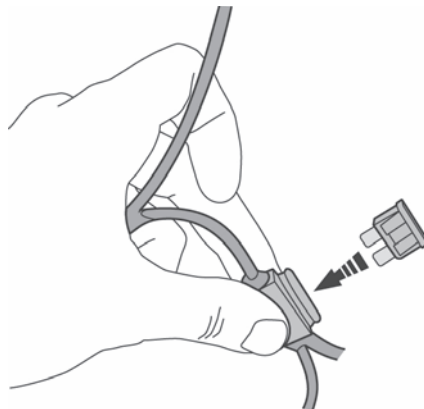

28 Test Doors and PowerBoards®

Open the doors to make sure that the PowerBoard® drops into position on each side of the vehicle. Reinstall any remaining trim panels.

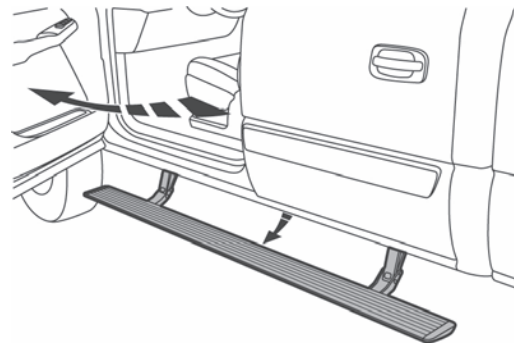

29 Adjust Running Board Position

Shut all doors and check to see if there is a gap between the running board and the body. If the running board is touching the body add spacers between the body pinch weld and linkage mounting flange as shown until the board no longer touches the body.

Cycle boards several times and then fully tighten all bolts.

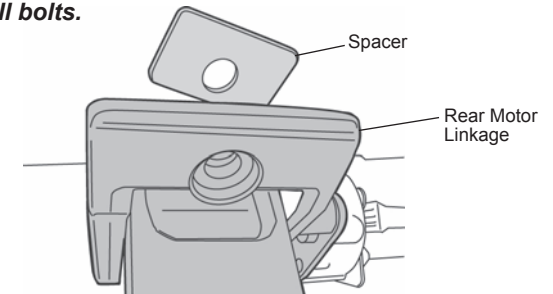

PowerBoard® – Installation Instructions

PowerBoard® Troubleshooting

Issue:

- Possible cause

Boards do not operate:

- Connected to incorrect vehicle wire
- Wire connections not secure
- Fuse burned
- Factory door-ajar circuit inoperable

Board creaks or squeaks during operation:

- Gear shaft wedge bolt is loose
- Loosen mounting bracket and board attachment screws. Adjust linkages so they are parallel to each other and the noise is gone. Tighten all fasteners.

Intermittent operation:

- Wire connections not secure
- Bad ground
- Bad battery connection

Boards operate randomly:

- Wire connections not secure
- Connected to incorrect vehicle wire

Board stays down all the time and can be moved by hand:

- Gear shaft wedge screw is missing or loose

Board shakes and or shutters during operation:

- Bad ground
- Wire connections not secure
- Bad battery connection

One or more doors operate the board and other do not:

- Wire connections not secure

PowerBoard® Service Tips

Confirming PowerBoard® is functional-black controller:

To test if the black controller (460.91), wire harness, motor and lights work, hook up to battery and touch any of the 4 door trigger wires to ground. The board for that side should go down and the lights should turn on. The board should go up and the lights should turn off when the wire is removed from ground.

Boards don't operate correctly when connected to wires identified in instructions:

Unfortunately vehicle manufacturers do not consistently keep the same wire colors in their wire harnesses. The PowerBoard® trigger wires need to be connected the factory door-ajar wire that is connected to each door latch switch. The correct wire is likely in the same bundle that is identified in the instructions. If none of them work you can locate the correct wire by removing the door panel and tracing the wire bundle that leads to the door latch.

Use an ohm meter or continuity tester to find the door-ajar wire on PowerBoards® with black controllers. The correct wire will go from neutral to ground when the door is opened and return to neutral when the door is shut. Connect one test lead to the negative battery terminal and probe the wires with the other lead. You can use a pin or a Posi-Tap connector to pierce the wire insulation. The correct wire will make the tester go from no continuity to complete continuity when the door opened and return to no continuity when the door is shut. You can also shut the door latch with the door open by pushing on the latch catch with a screw driver.

Linkage Component Identification

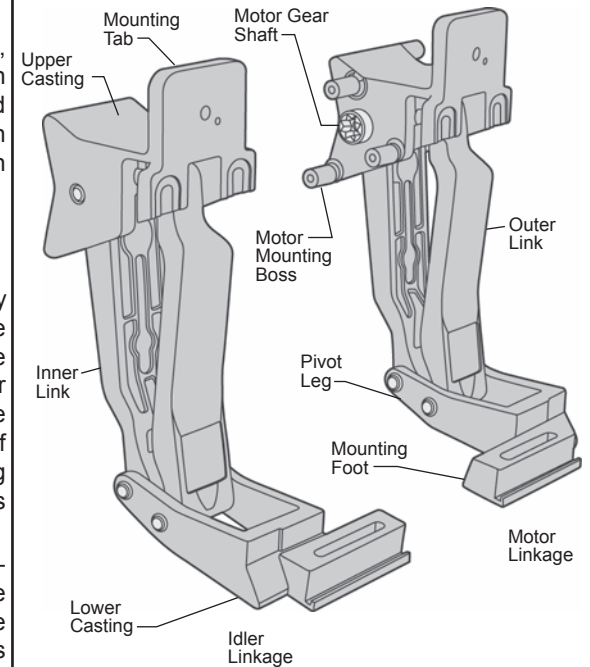

PowerBoard® – Installation Instructions

Care and Maintenance

The step pad surface and linkage arms should be washed with mild soap and water using a soft brush or sponge to dislodge any mud, dirt or accumulated road grime. Rinse with fresh water and avoid spraying the motors directly. After it is dry, lubricate the hinge with 3-IN-ONE Oil.

To prevent slipping, avoid applying waxes, lubricants or protectants like Armor All® to the step surface.

Attention!

TrekStep™ SHOULD ALWAYS BE STOWED IN THE RETRACTED POSITION WHEN DRIVING.

LIMITED WARRANTY

We warrant our product to be free from defects in material and workmanship, for the terms specified below, provided there has been normal use and proper maintenance. This warranty applies to the original purchaser only. All remedies under this warranty are limited to the repair or replacement of any item or items found by the factory to be defective within the time period specified. If you have a warranty claim, first you must call our factory at the number below for instructions. You must retain proof of purchase and submit a copy with any items returned for warranty work. Upon completion of warranty work, if any, we will return the repaired or replaced item or items to you freight prepaid. Damage to our products caused by accidents, fire, vandalism, negligence, misinstallation, misuse, Acts of God, or by defective parts not manufactured by us, is not covered under this warranty.

THE WARRANTY TIME PERIOD IS AS FOLLOWS FOR ALL POWERBOARDS® MANUFACTURED BY OUR COMPANY: THREE YEARS / 36,000 MILES FROM DATE OF PURCHASE.

ANY IMPLIED WARRANTIES OF MERCHANTABILITY AND/OR FITNESS FOR A PARTICULAR PURPOSE CREATED HEREBY ARE LIMITED IN DURATION TO THE SAME DURATION AND SCOPE AS THE EXPRESS WRITTEN WARRANTY. OUR COMPANY SHALL NOT BE LIABLE FOR ANY INCIDENTAL OR CONSEQUENTIAL DAMAGE.

Some states do not allow limitations on how long an implied warranty lasts, or the exclusion or limitation of incidental or consequential damages, so the above limitations or exclusions may not apply to you. This warranty gives you specific legal rights, and you may also have other rights which vary from state to state.



For further information or request for warranty work, please contact:

Bestop Inc. Customer Service

Toll-Free: (800)845-3567

Main: (303)465-1755

E-mail: csbestop@Bestop.com

Website: www.Bestop.com

PowerBoard® – Installation Instructions

