



Installation Instructions Supertop for Trucks

Vehicle Application:
Ford F150 5.5" Bed 2015 - Current
Part Number 77309

Installation Tips

Before you begin installing your new Supertop, please read all the instructions thoroughly. It is recommended that two people install this Bestop product.

For a smooth fit:

For easier installation, the top should be installed at a temperature above 72° F. Below this temperature, the fabric may contract an inch or more, making it difficult to fit the vehicle. You may let the fabric sit in the sun for 15-20 minutes before installing to let the fabric warm up.

It is normal for the fabric to contract and wrinkle when stored in the shipping carton. Within a few days after installation, the fabric will relax and the wrinkles will disappear.

WARNING Do not rely in any way on the components of this product to protect against injury or death in the event of an accident. Never operate the vehicle in excess of manufacturer's specifications.

Read and follow, precisely, all installation instructions provided when installing this product. Failure to do so may result in a poor fit and could place occupants of the vehicle in a potentially dangerous situation.



CAUTION Safety glasses should be worn at all times when installing this product.

WEAR SEAT BELTS AT ALL TIMES

Tools



Safety Glasses



9/16" Wrench



1/8" Hex Key

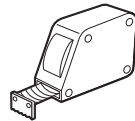

Tape Measure

Installation Time

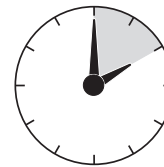

2 Hours

Skill Level



3 - Moderately Difficult

Support

We're here to help! Go to:
<https://www.bestop.com>
and click on Need Help?



<https://www.bestop.com/video-library>



Sugerencias de Instalación

Antes de empezar a instalar esta unidad, lea atentamente todas las instrucciones.

Para un buen ajuste:

Para facilitar la instalación, el producto debe instalarse a temperaturas superiores a 72 °F (22 °C).

Por debajo de esta temperatura, la tela puede encogerse una pulgada o más, lo que dificultaría su ajuste al vehículo.

Es normal que la tela se contraiga o arrugue cuando está guardada en la caja de empaque. A los pocos días después de la instalación, la tela se relajará y las arrugas desaparecerán.



ADVERTENCIA

Este producto se diseñó principalmente para mejorar la apariencia del vehículo y proteger a los ocupantes de las condiciones climáticas comunes. De ninguna manera piense que los componentes de este producto pueden servir como medio de contención para los ocupantes del vehículo o que pueden protegerlos contra lesiones o la muerte en caso de accidente. Este producto no protegerá a los ocupantes contra caídas de objetos. Nunca conduzca este vehículo fuera de las especificaciones del fabricante.

USE LOS CINTURONES DE SEGURIDAD EN TODO MOMENTO

Lea y siga con precisión todas las instrucciones de instalación que se proporcionan para instalar este producto. Si no lo hace, podría producirse un mal ajuste que colocaría a los ocupantes del vehículo en una situación potencialmente peligrosa.



PRECAUCIÓN

Debe usar gafas protectoras en todo momento durante la instalación de este producto.

Conseils pour l'installation

Lire toutes les instructions au complet avant de commencer l'installation de cet assemblage.

Pour un ajustement sans problème :

Afin de faciliter l'installation, ce produit doit être installé à des températures au-dessus de 72 °F (22 °C).

Sous cette température, le tissu peut rétrécir d'un pouce (2,5 cm) ou plus, ce qui rendra l'ajustement sur le véhicule difficile.

Il est normal que le tissu rétrécisse et plisse pendant qu'il est dans la boîte d'expédition. En quelques jours après l'installation, le tissu se détendra et les plis disparaîtront.



AVERTISSEMENT

Ce produit est conçu principalement pour améliorer l'apparence du véhicule et pour protéger les occupants des conditions météorologiques usuelles. Ne jamais se fier aux composants de ce produit pour se protéger de blessures ou de la mort en cas d'accident. Ce produit ne protégera pas les occupants des chutes d'objets. Ne jamais utiliser le véhicule au-delà des caractéristiques techniques indiquées par le fabricant.

PORTER UNE CEINTURE DE SÉCURITÉ EN TOUT TEMPS

Lire et suivre, très fidèlement, toutes les instructions d'installation fournies lors de l'installation de ce produit. Ne pas suivre cette consigne peut causer une installation inadéquate et mettre les occupants du véhicule dans une situation potentiellement dangereuse.



MISE EN GARDE

Des lunettes de sécurité doivent être portées en tout temps lors de l'installation de ce produit.

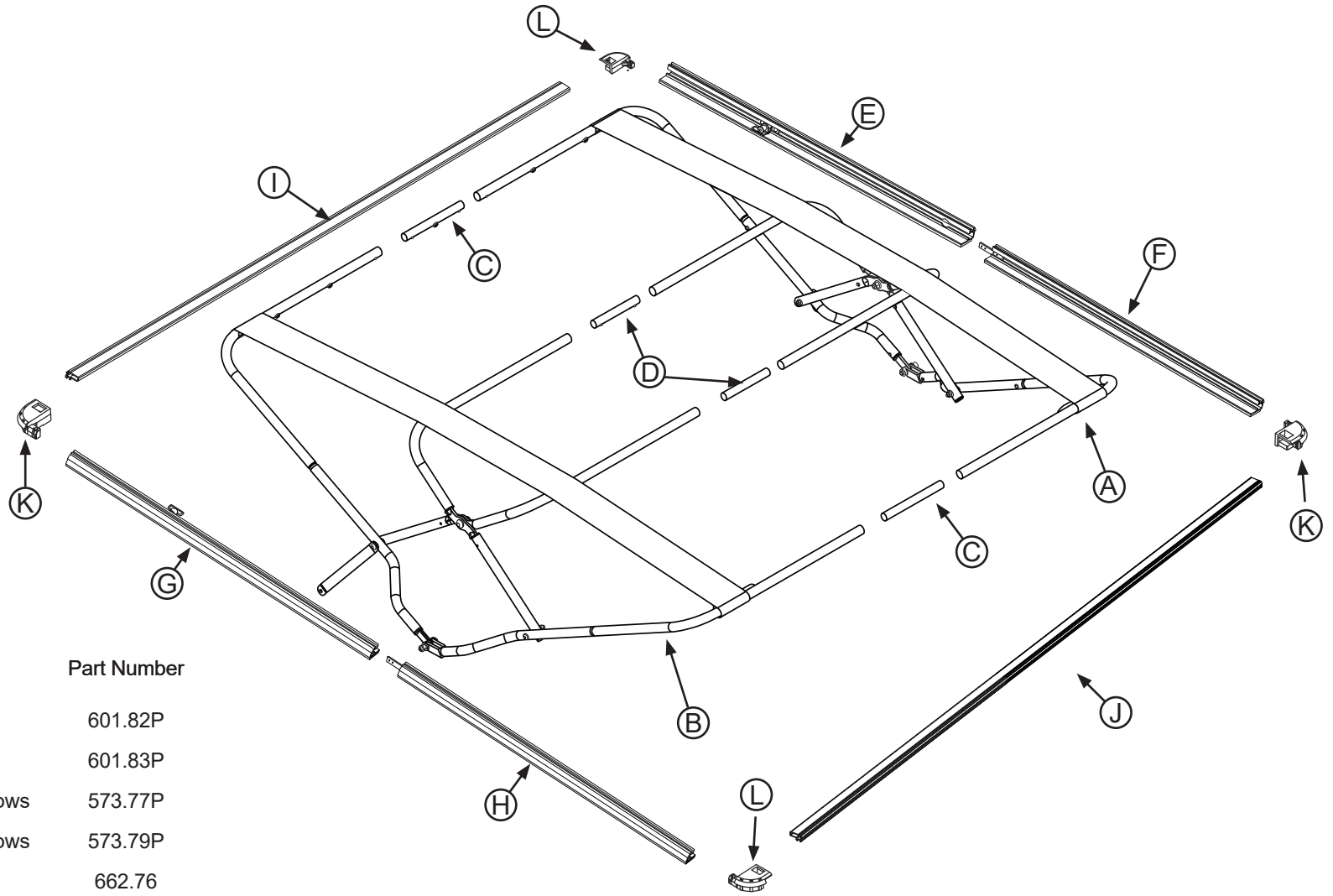

Description	Part Number
A Bow Assembly (Right)	601.82P
B Bow Assembly (Left)	601.83P
C Bow Couplers #1 and #4 Bows	573.77P
D Bow Couplers #2 and #3 Bows	573.79P
E Front Side Rail (Right)	662.76
F Rear Side Rail (Right)	662.84
G Front Side Rail (Left)	662.77
H Rear Side Rail (Left)	662.85
I Front Rail (65 5/8")	663.62
J Rear Rail (63 3/8")	663.61
K Right Corner (2 Each)	657.36
L Left Corner (2 Each)	657.37

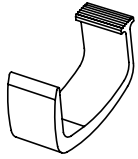

Lower Clamp (Small)
Part #595.34
Qty. 2

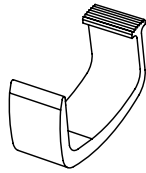

Lower Clamp (Large)
Part #579.23
Qty. 2

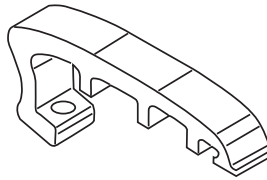

Outer Clamp - Large
Part #579.22
Qty. 4



#8-32 Nut
Part #720220
Qty. 4

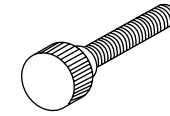

Thumb Screw
Part #720215
Qty. 4



Set Screw
Part #573.17
Qty. 4

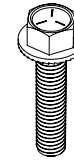

Hex Head Bolt
Part #578.39
Qty. 4

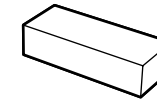
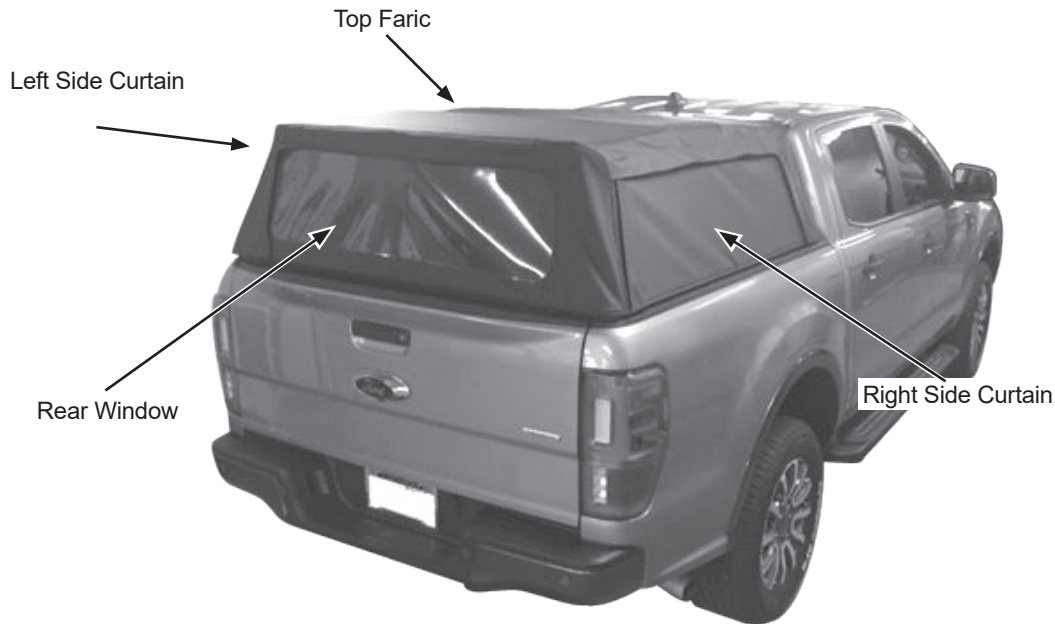

Rubber Pad
Part #720035
Qty. 4

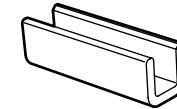

Clamp Pad
Part #577.39
Qty. 2

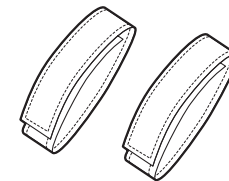

Tie Down Strap
Part #410.42
Qty. 2

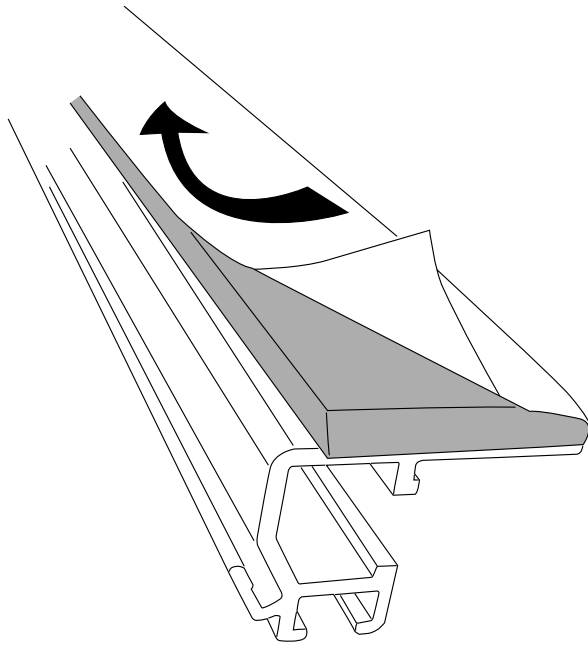

Locate the Foam Tape on the Left and Right Side Rails, and remove the paper backing from the foam tape.

Repeat with all Side Rails.

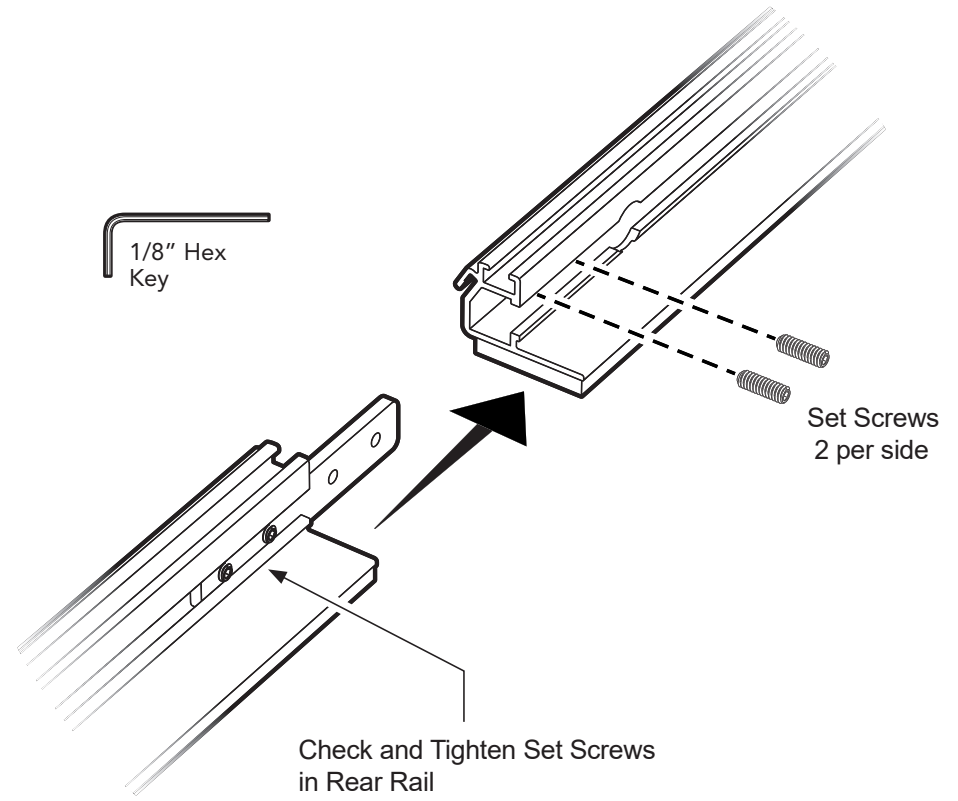

Assemble the Left Front Side Rail and the Left Rear Side Rail.

Slide the rails together, and secure using two set screws.

Check and tighten the two (2) set screws in the rear rail.

Repeat with the Right Side Rails.

Passenger front side shown

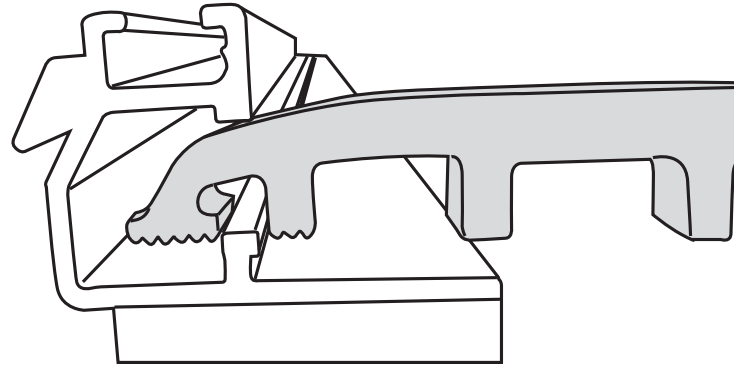
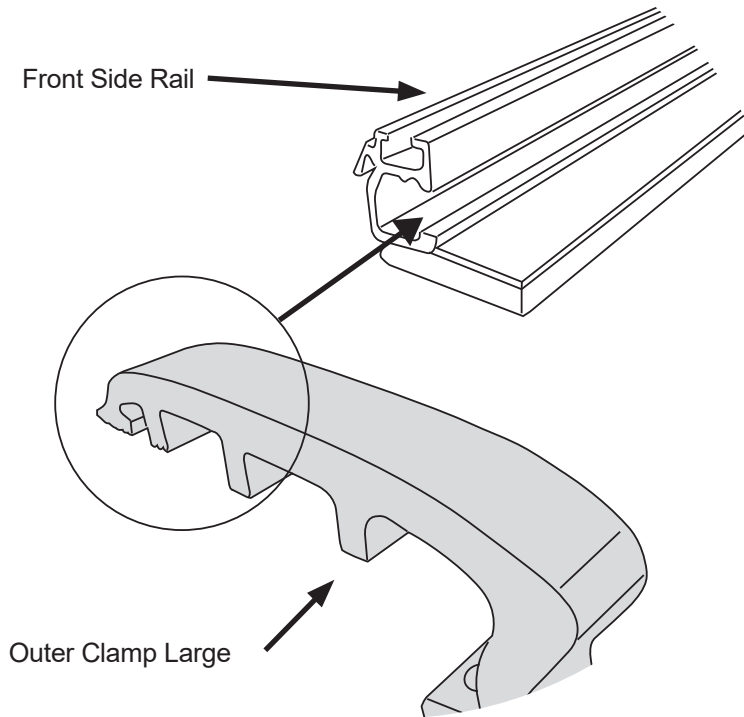

Insert one clamp on each of the Front Rails and two on each of the Rear Rails.

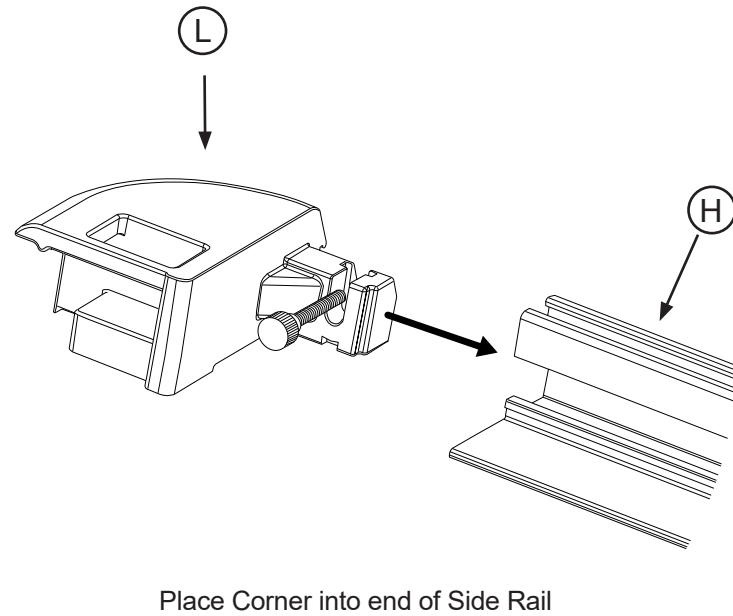
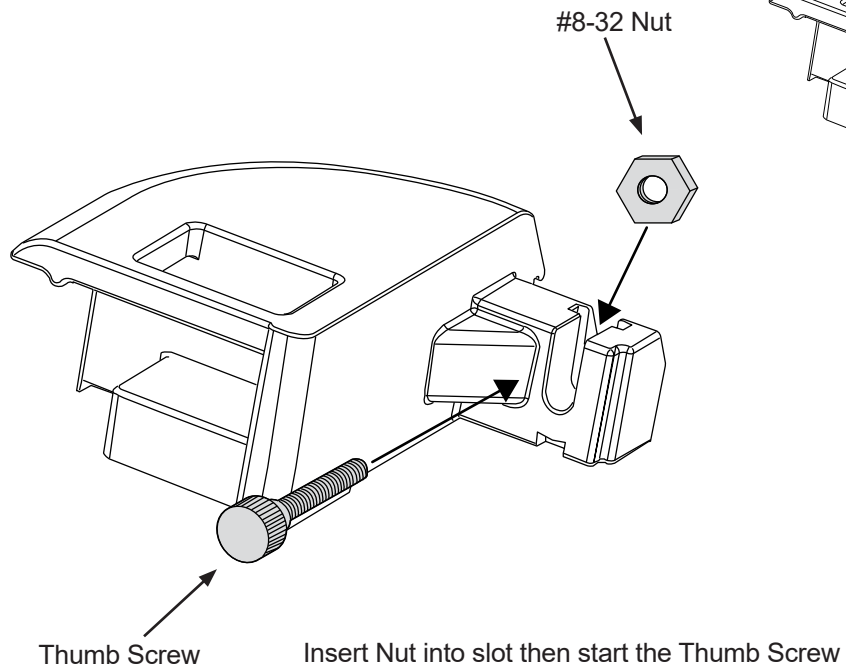

Repeat on both ends of the side rails

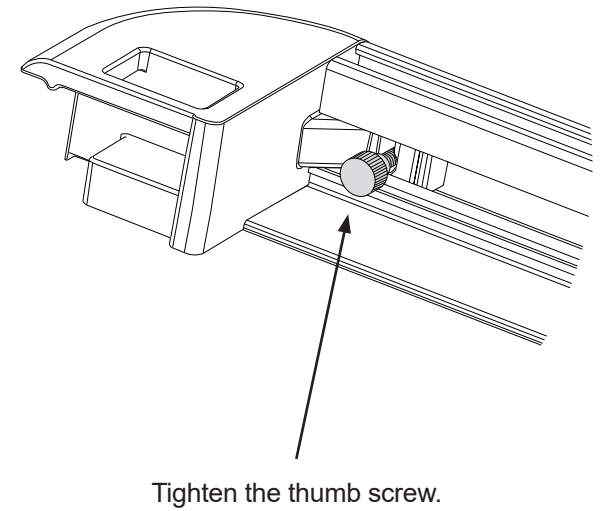

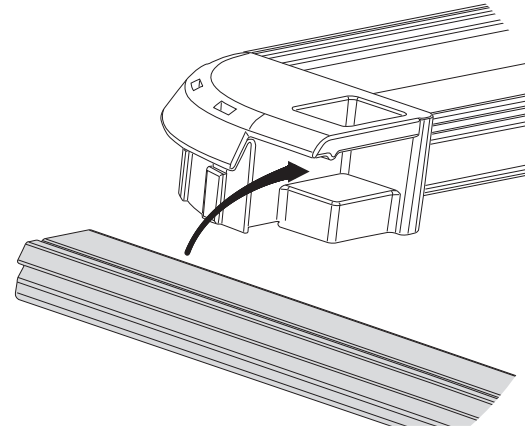
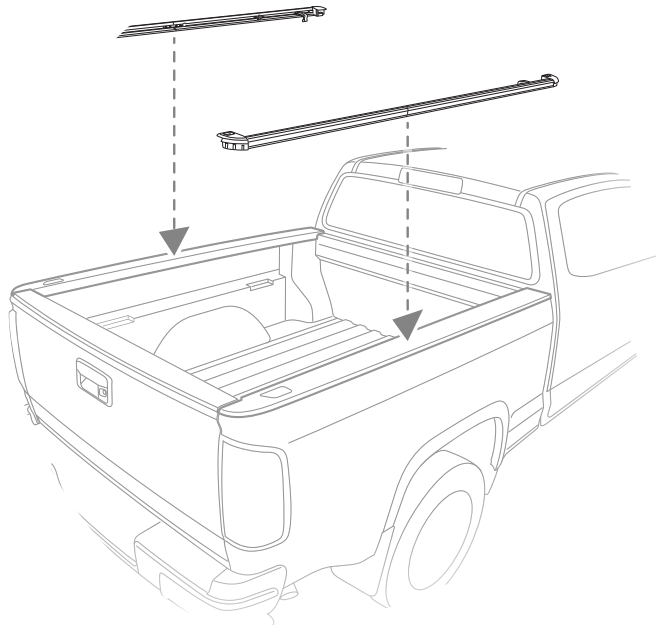

Insert Rear Rail into the corners on the Side Rails.

Tip

It is recommended to have someone help you with this step.

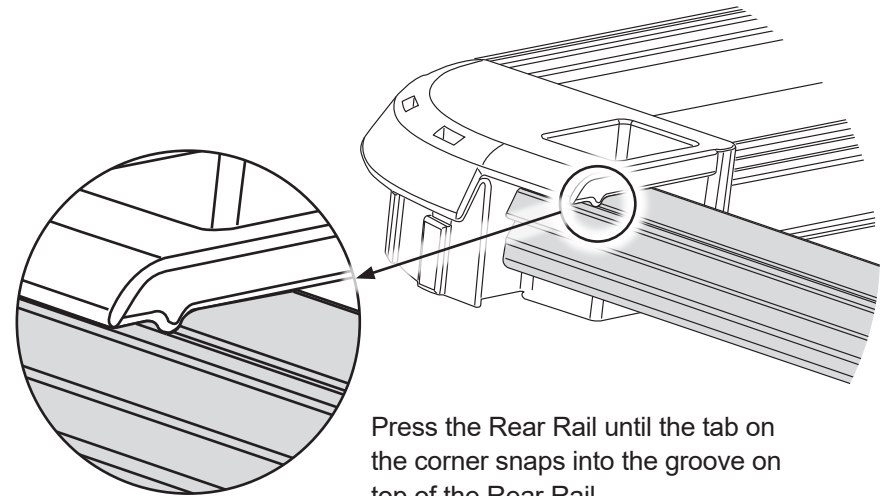

Press the Rear Rail until the tab on the corner snaps into the groove on top of the Rear Rail.

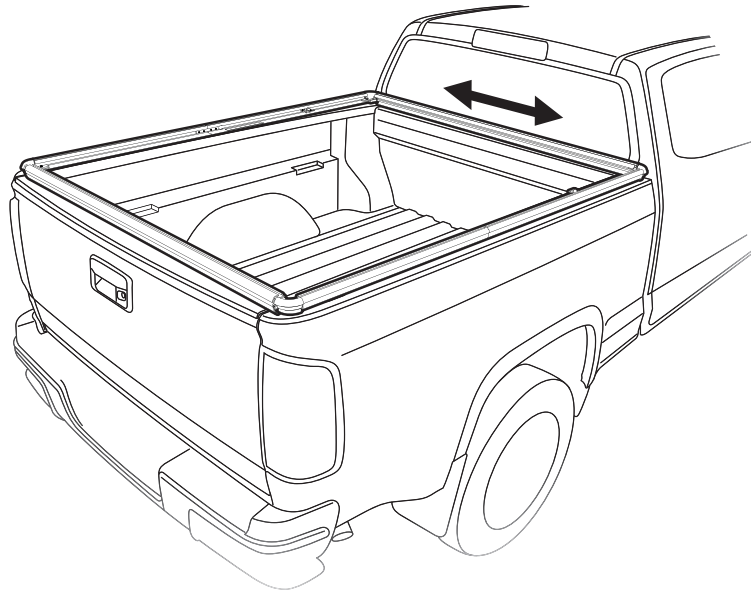

Adjust the Side and Front and Rear Rail assembly right-to-left to center it on the bed width.

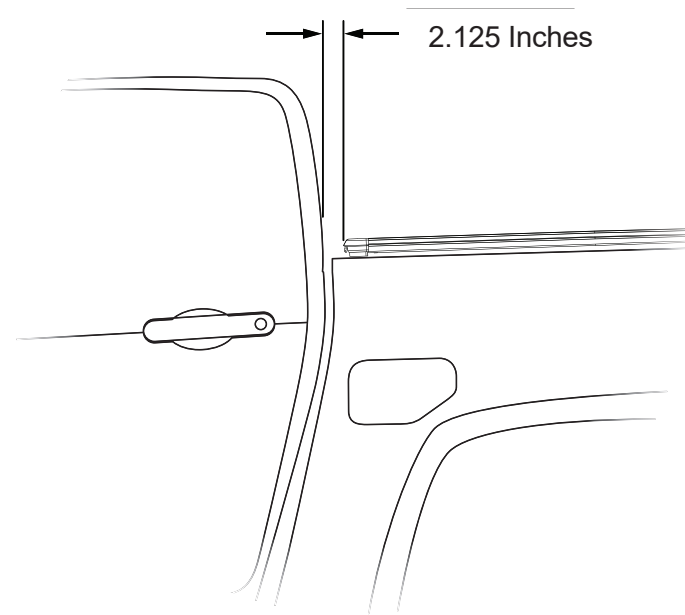

Place the outer edge of both side rail corners 1.75 inches from the back of the vehicle cab.

Driver Side Shown

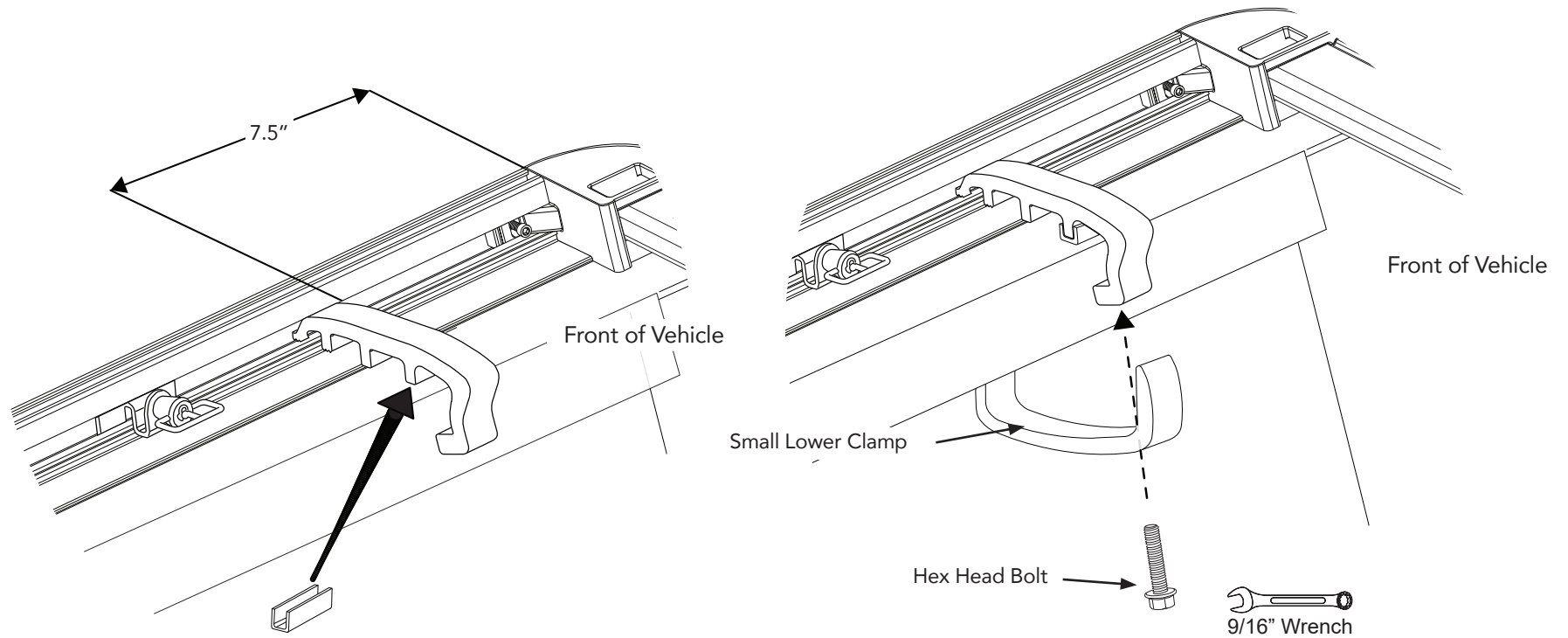

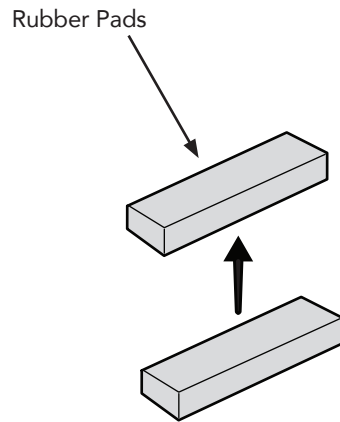

Attach two (2) Rubber Pads together.

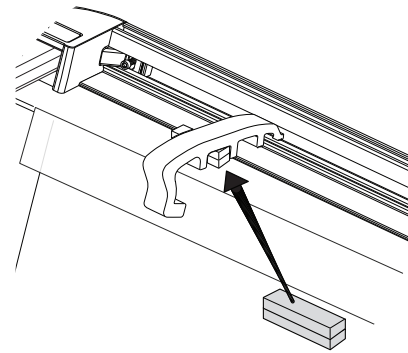

Place the 2 Rubber pads under the Upper Clamp.

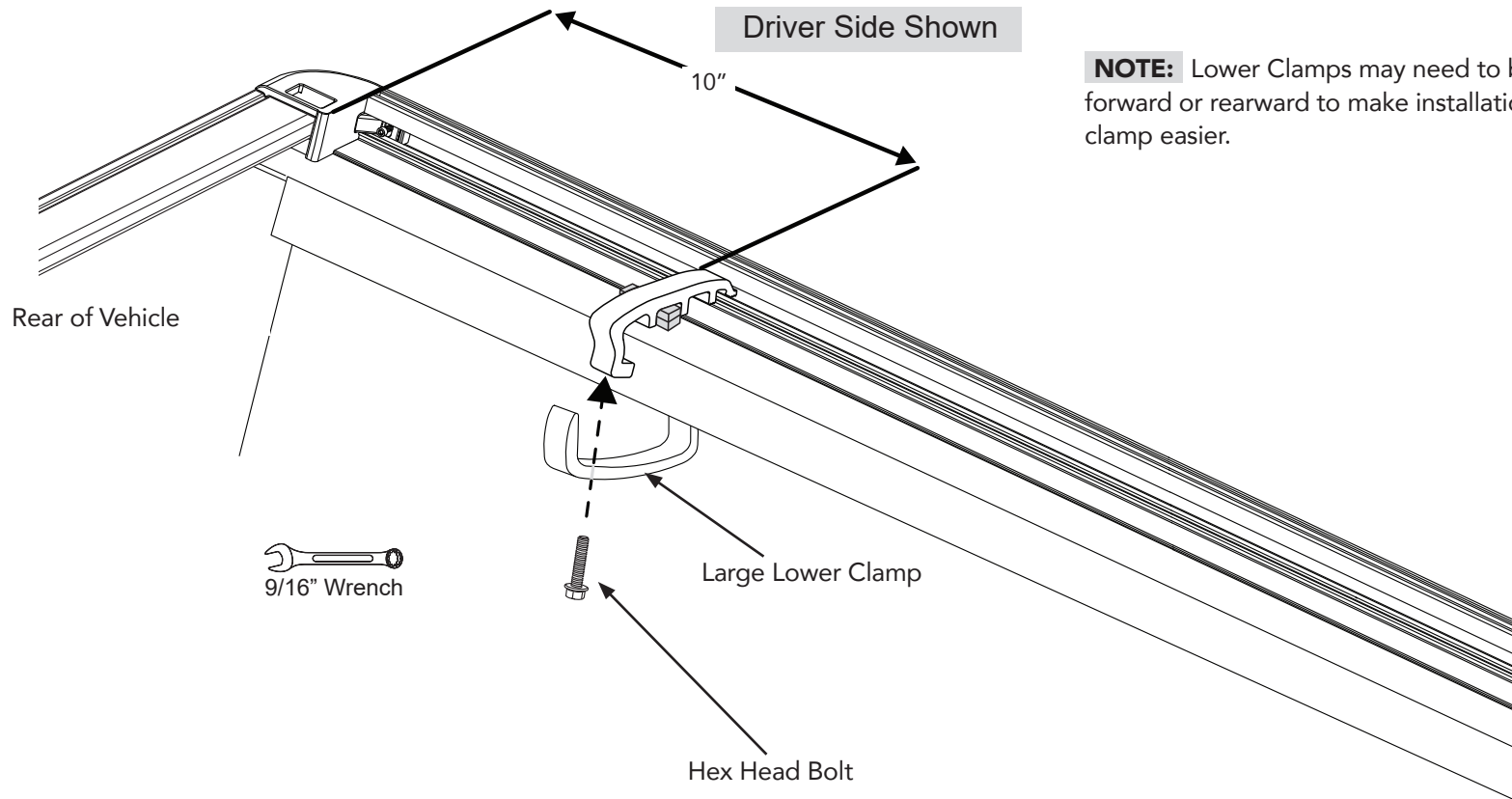

NOTE: Lower Clamps may need to be moved either forward or rearward to make installation of the upper clamp easier.

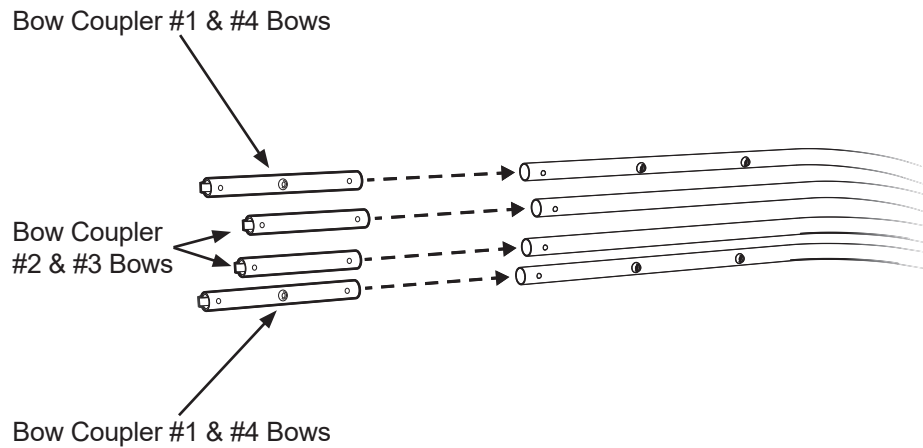

Attach Bow Couplers to the Passenger Side Bow Stack.

Insert Long Couplers into the outer bows #1 and #4.

Insert Short Couplers into the inner bows #2 and #3.

For Easier Installation:

Slide all bows and couplers together before snapping the spring clips into the holes in the bows.

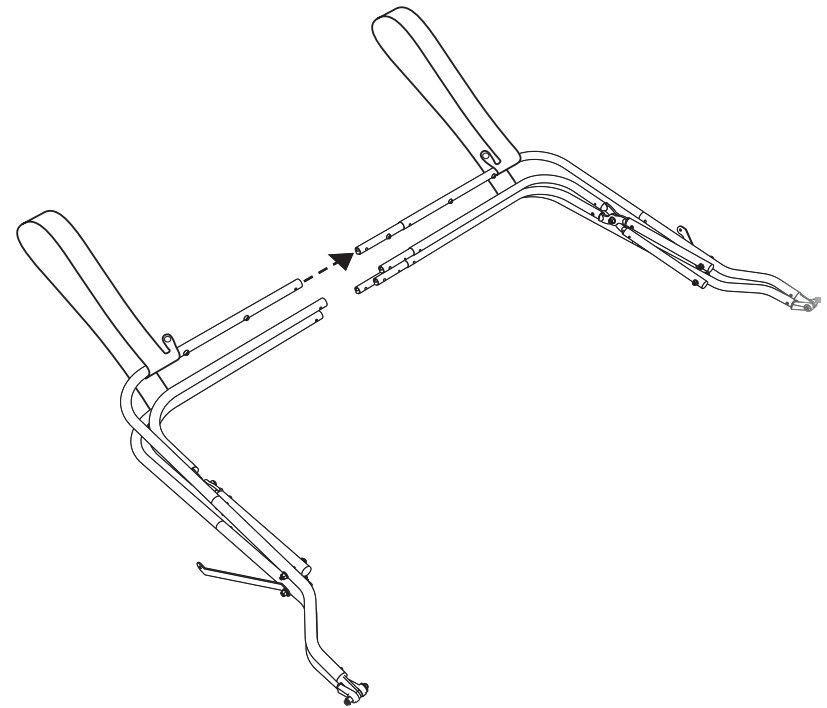

Attach Driver Side Bow Stack to the Passenger Side Bow Stack.

Slide the Couplers installed in the Passenger Side Bow Stack into the ends of the bows on the Drivers Side Bow Stack.

NOTE: Before attaching couplers to bowstacks, make sure to pull the bond coat straps out and away from the bows, and lay them flat.

Passenger Side Shown

Details

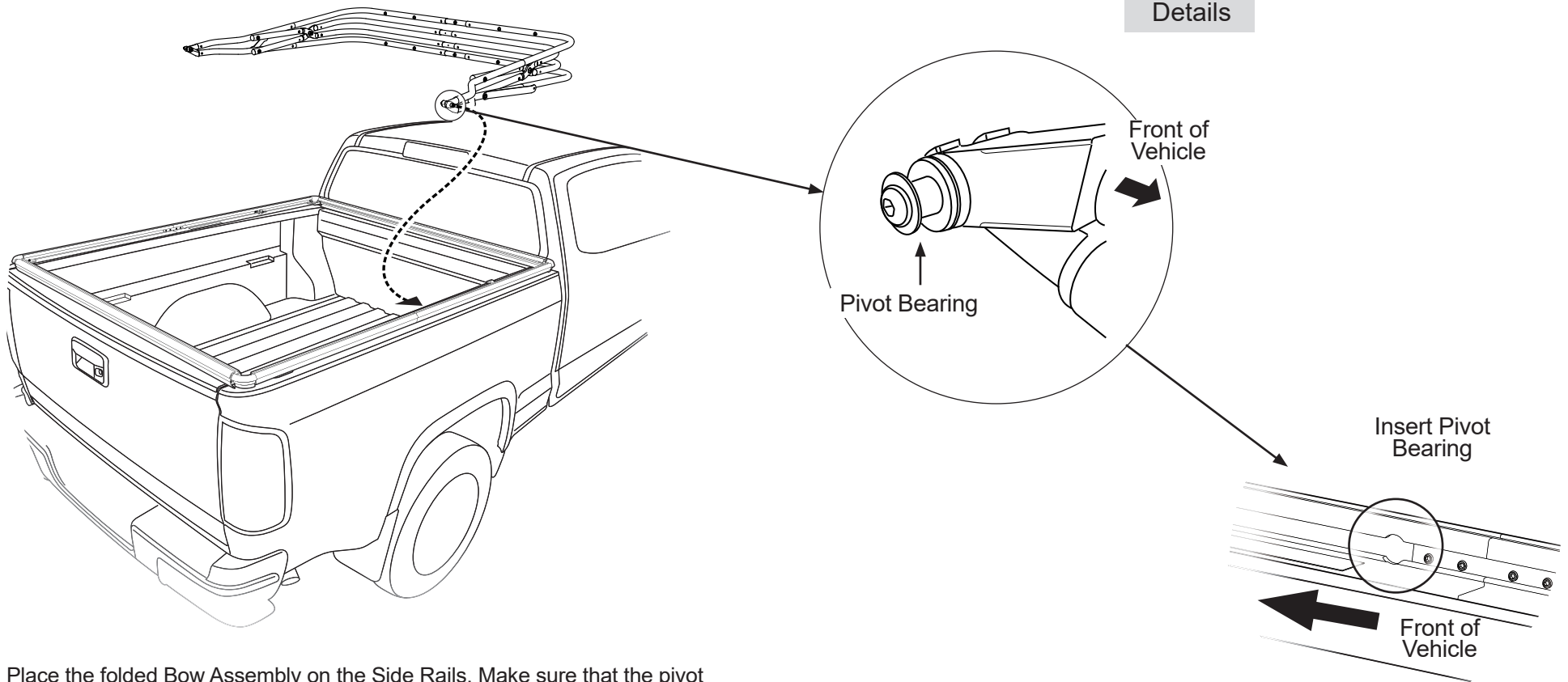

Place the folded Bow Assembly on the Side Rails. Make sure that the pivot swing arm braces are on the lowest bow.

Insert the Pivot Bearings into the receiving holes in the inside of the side rails. See Details.

Repeat on left side of vehicle.



It is recommended to have someone help you with this step.

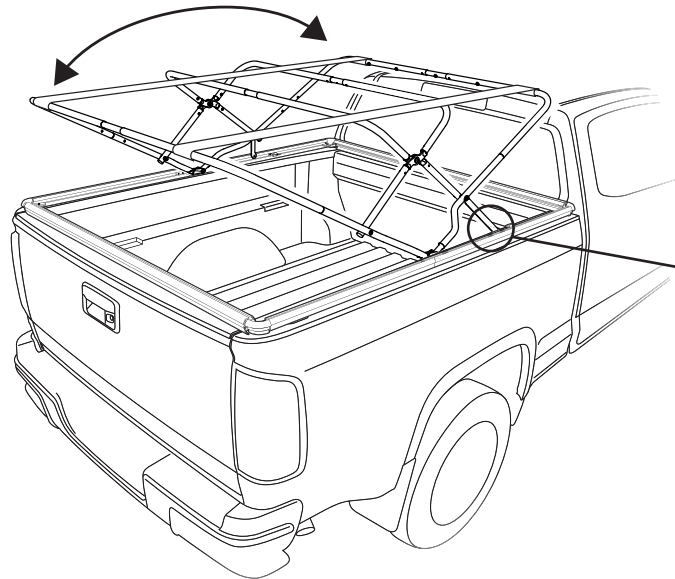

Unfold the Bow Assembly.

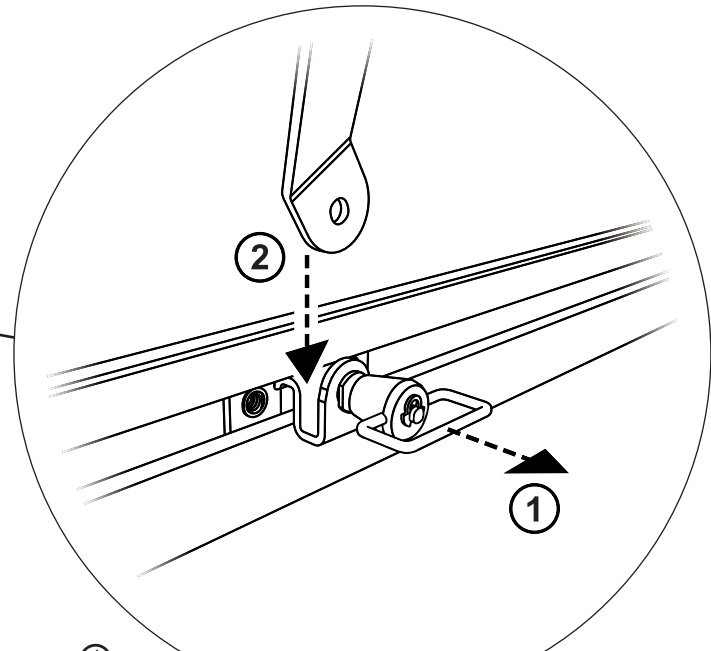

- ① Pull back on the Pivot Knuckle release knob;
- ② Snap the Pivot Arm Brace into place, on both sides of the truck.

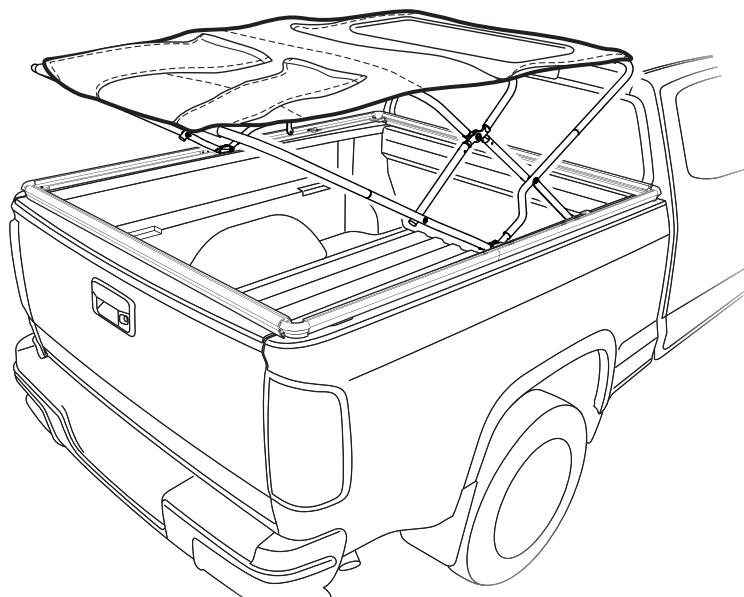

Place the folded Soft Top onto the unfolded Bow Assembly.

NOTE: Window should go towards the front of the Bow Assembly.

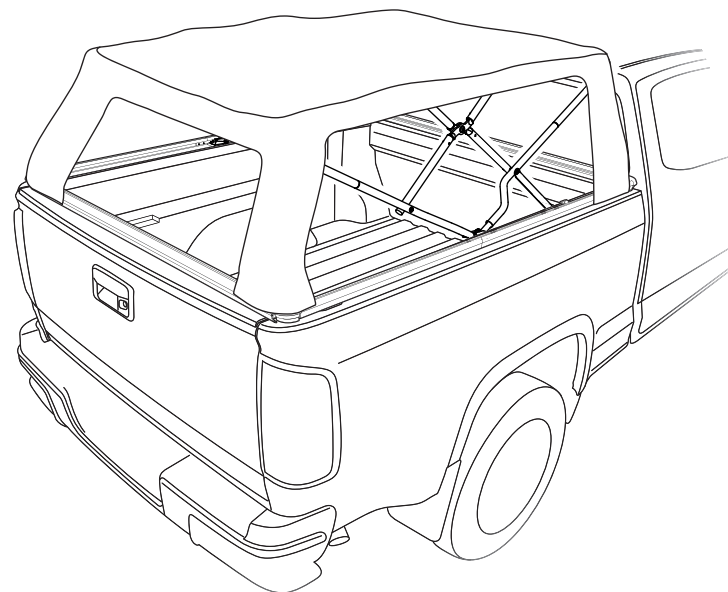

Unfold the front and back of the Top over the #1 and #4 Bows.

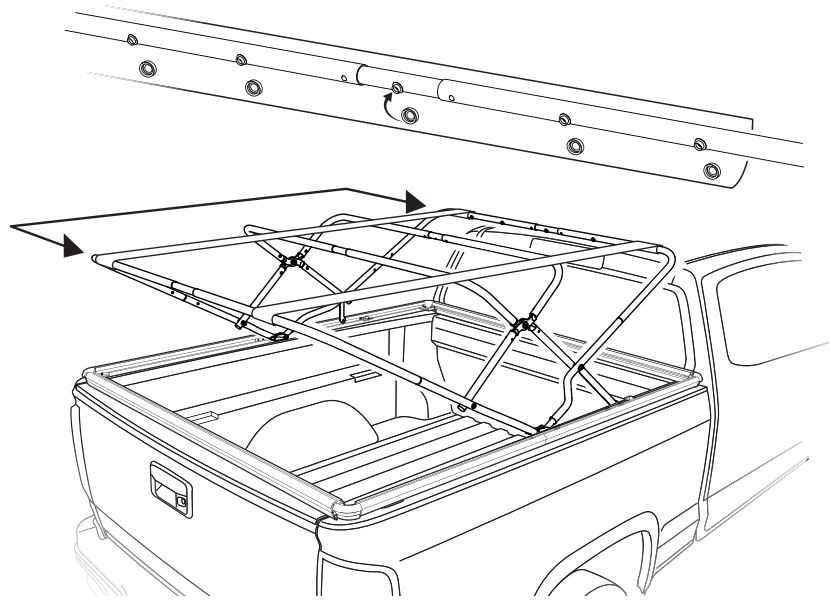

From inside the truck bed:

Wrap the fabric flap around the #1 Bow and snap all five snaps to secure the fabric to the Bow.

Repeat for the #4 Bow (Bow closest to the truck tailgate).

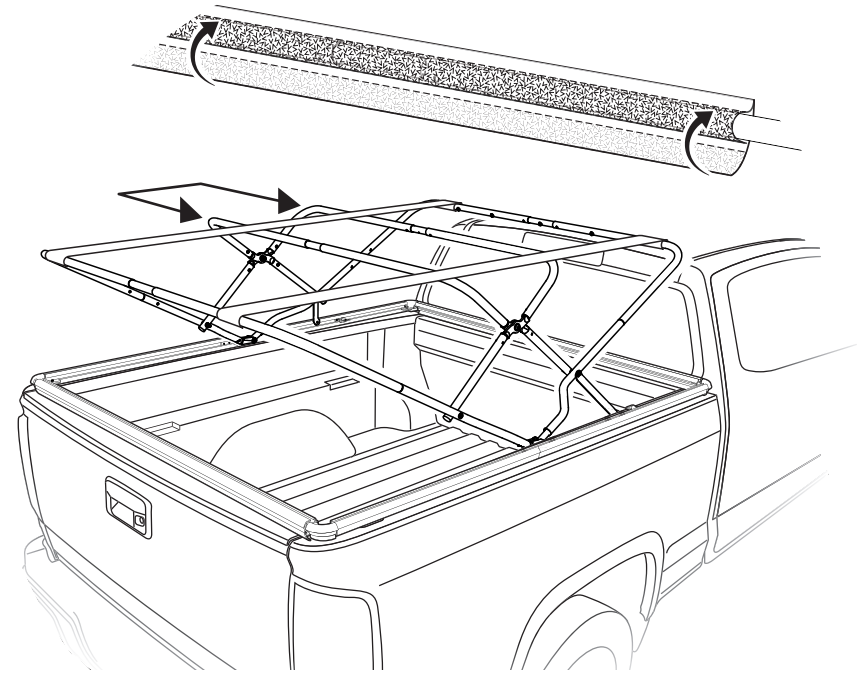

From inside the truck bed:

Wrap the fabric flaps with hook-and-loop around the #2 and #3 bows (the two middle bows) to secure the top fabric to these Bows.



Secure the outer snaps before securing the center snaps.

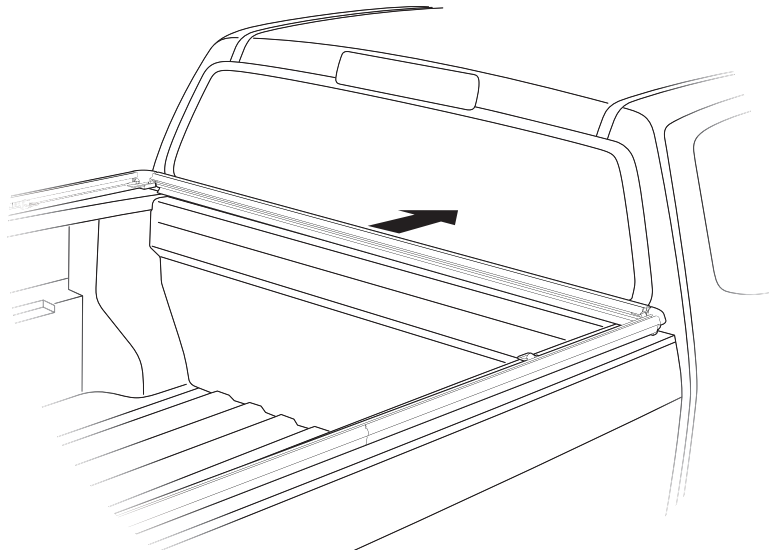

Remove the front rail, by sliding it toward the front of the truck bed.

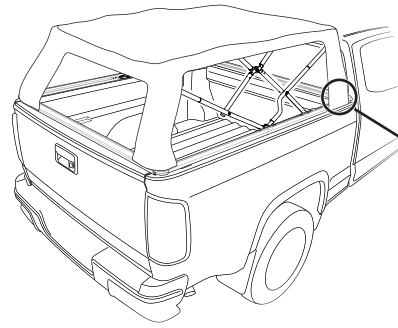

Slide the front rail onto the plastic retainer at the bottom of the front window. The rail should go under the large flap. Re-install the Front Retainer into the plastic corners. See Detail.

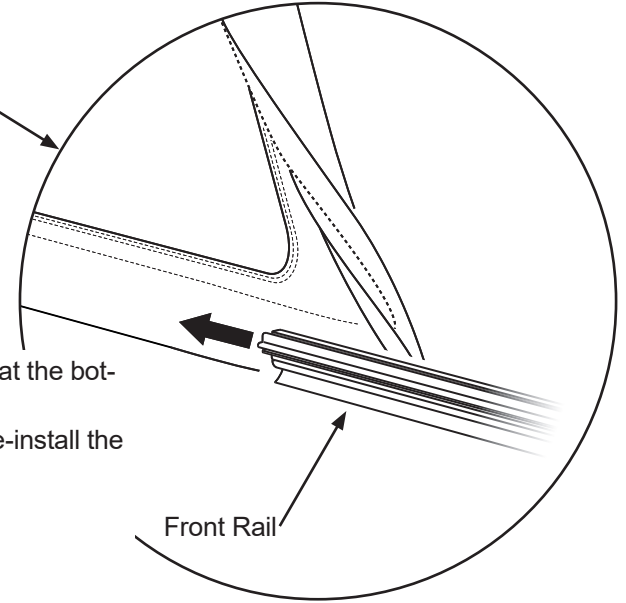

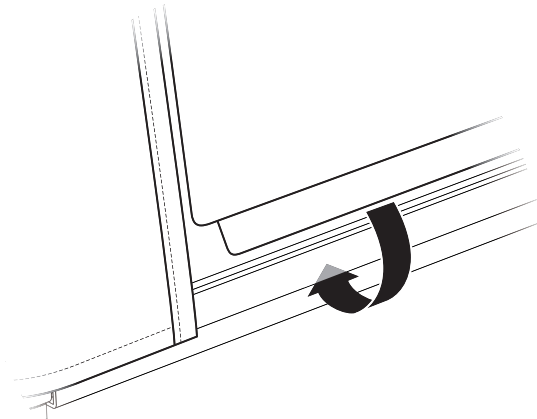
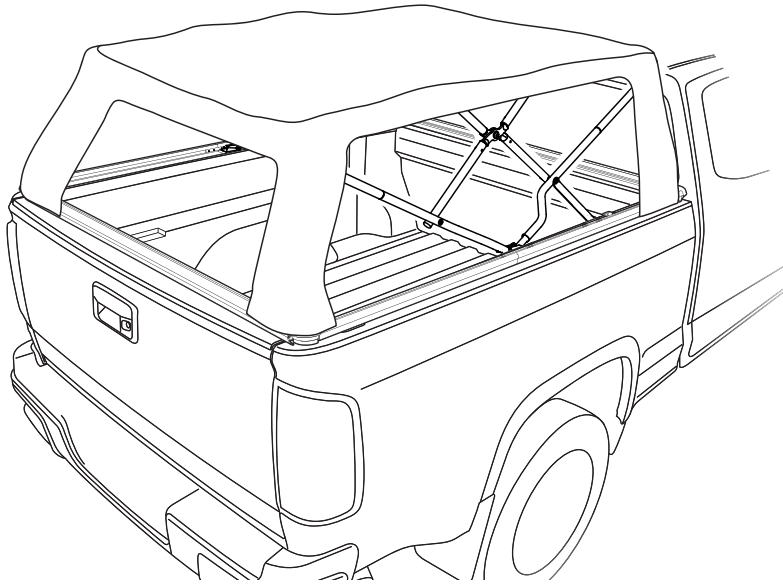

Tuck the plastic tab along the bottom edge of each Side Curtain into the slot along the side of each Side Rail.

Tuck the plastic tab along the bottom of the Rear Window into the slot along the side of the Rear Rail.

For easier access to the zippers, you may want to lift the corners of the top onto the roof fabric.

Zip the Rear Window and Side Curtains into place.

Start with the zipper along the top edge of each panel, and then follow with the side zippers. For ease of installation, start each zipper only about 6”.

Once all zippers are started, flip the rear corners into the rail, then zip all zippers completely shut.

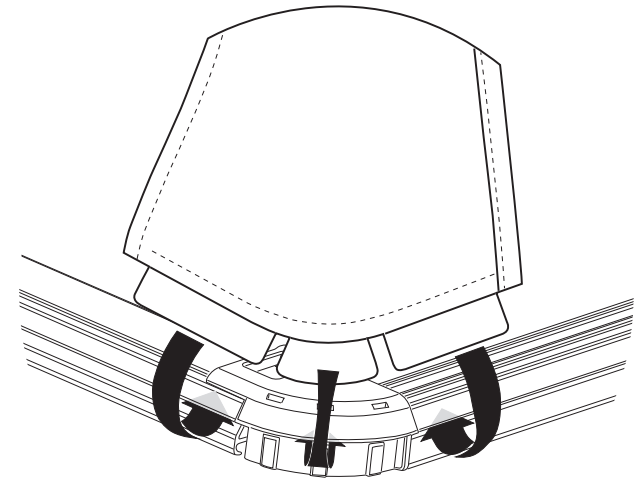

Tuck the plastic tabs at the bottom of each corner of the top into the slots in the Side Rails and Front and Rear Rails.

NOTE: It may be necessary to adjust the top as the weather gets hot to tighten the fabric.

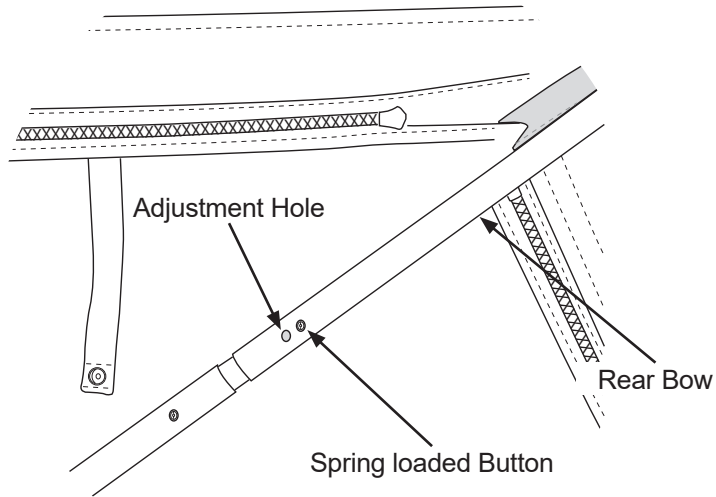
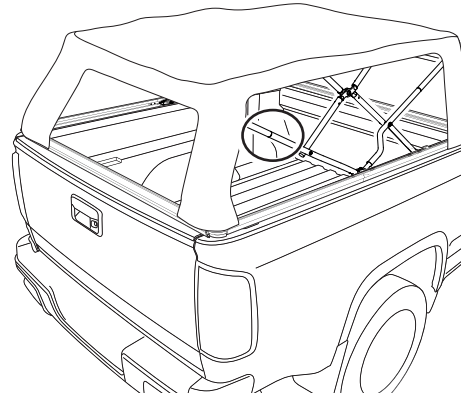

Take out Retainers from the Side Panels and Rear Corners.

Press the spring loaded button then slide the Rear Bow up until the button pops into the next hole.

Tuck in the Side Window Retainers and Corner Retainers.

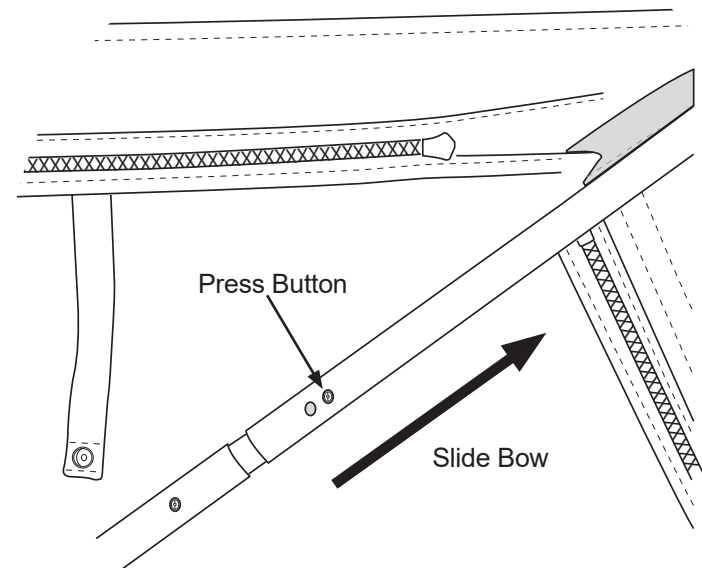

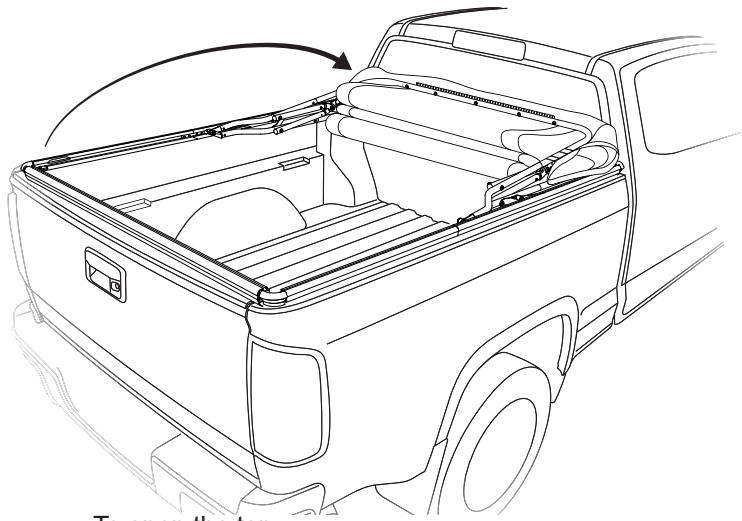

To open the top:

Unzip and remove Side Curtains.

Unzip and remove Rear Window.

Release plastic tabs from rails all around.

Flip rear corners of top fabric up onto roof.

Fold the top forward so that all the bows collapse and rest on the Front Rail.

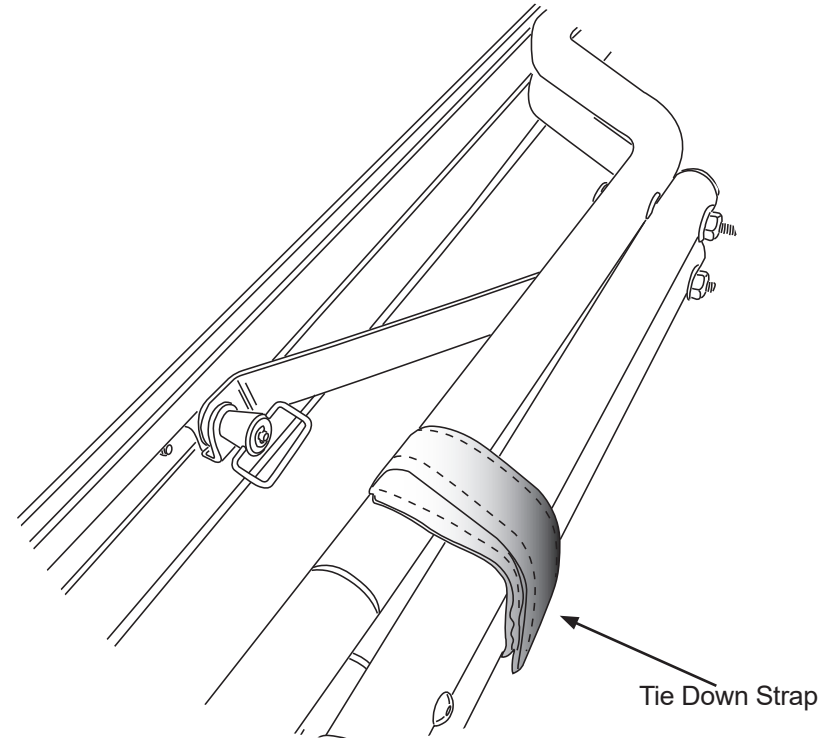

After the top is laid down, Wrap the Tie Down Straps (1 per side) around the bow stack.

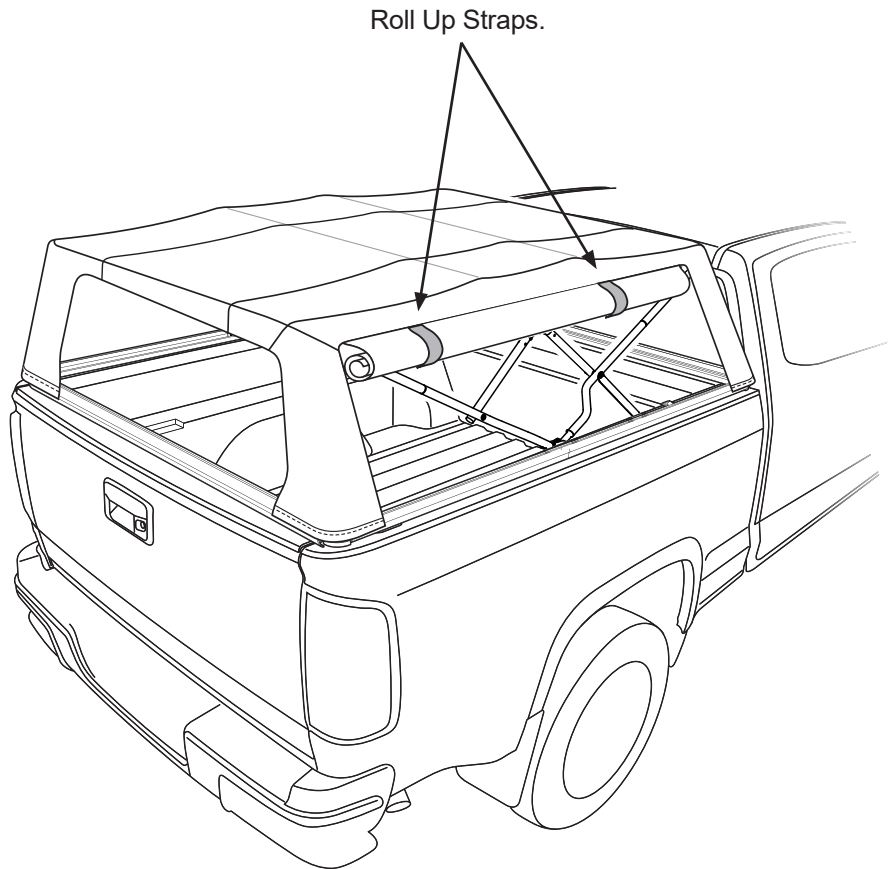

Roll Up Straps.

With the Fabric Top up, the Side Curtains can be rolled up and secured with Roll Up Straps.



Care and Maintenance of your Bestop Product

Your Bestop product is made of the finest materials available. To keep it looking new and for the maximum possible wear, it will need periodic cleaning and maintenance.

Fabric: The fabric should be washed often using soap, warm water and a soft bristle brush. Rinse with clear water to remove all traces of soap. Bestop recommends using Bestop Cleaner (part no. 11201-00) and Bestop Protectant (part no. 11202-00) for Vinyl fabric and Bestop Twill Protectant (part no. 11207-00) for Twill fabric. Bestop Cleaner and Bestop protectant are specially formulated to provide a total cleaning and protection system. Bestop Cleaner safely removes the toughest stains, will not harm vehicle finishes, is biodegradable and environmentally friendly. Bestop Protectant protects against UV-fading, cracking and hardening, and repels dust, grease, dirt and mildew.

Windows: Keep windows clean to avoid scratching. DO NOT use a brush on the windows! Wash with a water-soaked cloth or sponge and a mild dishwashing detergent. Bestop recommends Bestop Vinyl Window Cleaner (part no. 11203-00), which safely cleans and protects vinyl windows and helps prevent UV damage. NEVER WIPE THE WINDOWS WHEN THEY ARE DRY. Be careful when cleaning snow or frost from the vinyl windows since they are easily scratched and may crack at low temperatures. DO NOT roll the sides or rear window in cold weather. The windows become stiff and will crack. Cracks caused by misuse in cold temperatures are not covered under warranty.

Water: Seeping through at the seams may be stopped by applying 3-M Scotchgard® on the inside of the seams.

Snaps: Keep snaps cleaned and lubricated with silicone to help prevent snaps from sticking to the studs. If a snap does become stuck to a stud, use a screwdriver and GENTLY pry apart to prevent permanent damage to the snap or the top fabric.

Zippers: Keeping zippers cleaned and lubricated with Bestop's Zipper Cleaner (part no. 11206-00) will help prevent damage and keep the zippers in smooth working condition. If a zipper opens behind the slider, the slider may have been spread apart. This problem can usually be repaired by using an ordinary pair of pliers to bring the sides back into parallel. Return slider to the end of the zipper in the normal Open position. Squeeze lightly at first and test the zipper. If the zipper continues to remain open squeeze more firmly with the pliers and try the zipper again. Repeat this procedure until the zipper operates correctly.

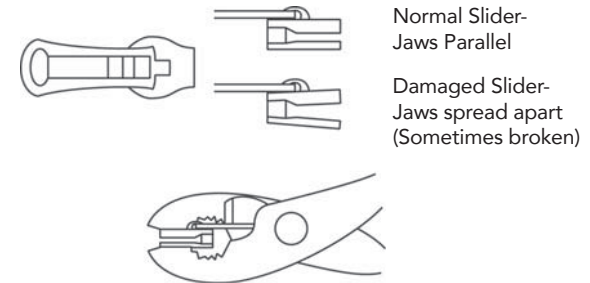

For Bestop Warranty Information, Please go to;
<https://www.bestop.com/help/warranty-information/>

