

Step Three

LOWER BOWS

Lower the bows and slide them as far forward as possible. The ends of the bottom bow should slide inside the Bow Mounts. This is necessary for the Duster to fit properly.

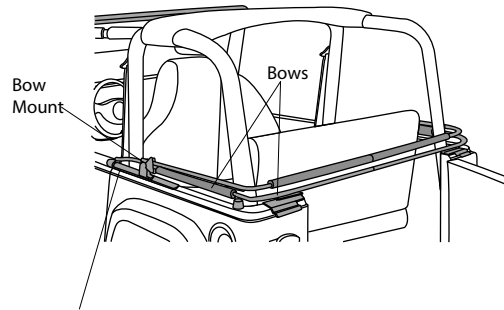

Slide Bow Ends as far forward as possible

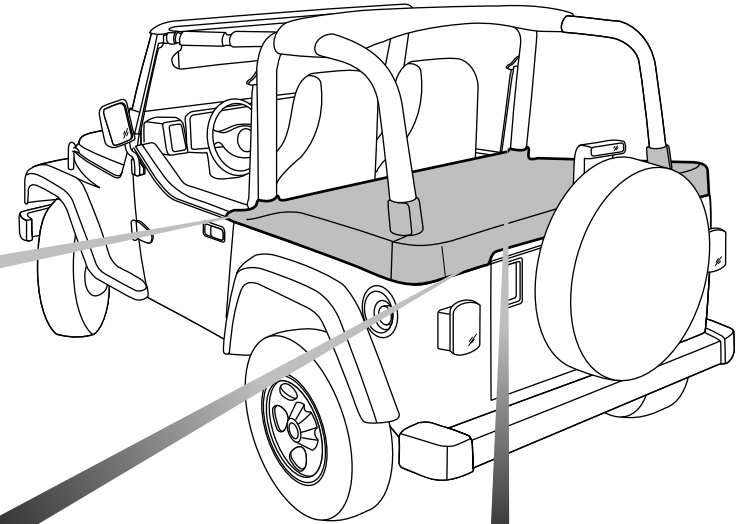

Step Four

INSTALL DUSTER ON TAILGATE BAR

Fold down the rear seat. Orient the Duster on the vehicle. Slide the rear edge of the Duster into the channel on the Tailgate Bar, open the tailgate and push the Tailgate Bar into the Tailgate Mounts on the vehicle.

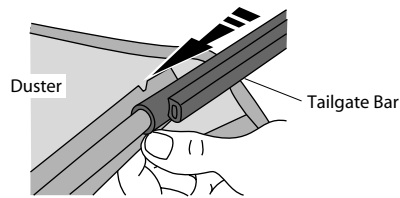

Slide Tailgate Bar onto rear of Duster

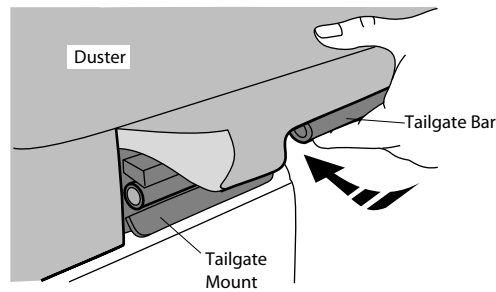

Step Five

FASTEN BUCKLE STRAPS

Drape the fabric forward over the rear of the vehicle and locate the web straps with buckles sewn to the front of the Duster. Wrap the straps around the front sport bars and thread the ends loosely through the buckles. Do not pull the straps tight at this time. Tighten the buckle straps on the front of the duster.

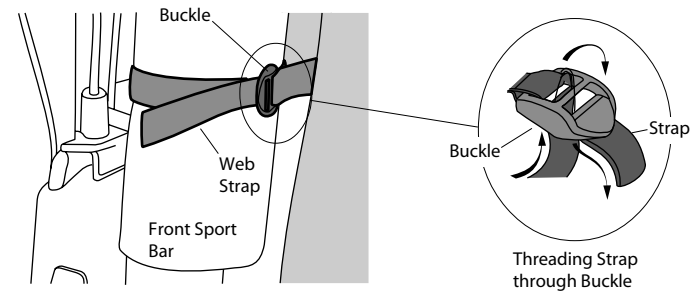

Note: Do not wrap the straps around the seat belt

Step Six

INSTALL PLASTIC STRIP INTO SIDE BELT RAILS

Make sure that the front edge of the Duster covers the front of the Side Belt Rails. Locate the plastic strip sewn into the sides of the Duster. Start at the rear on each side and roll the plastic strip into the Side Belt Rails.

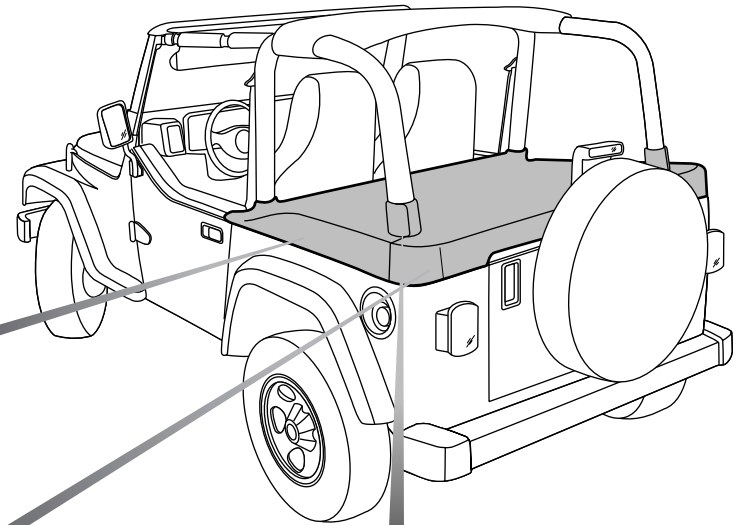
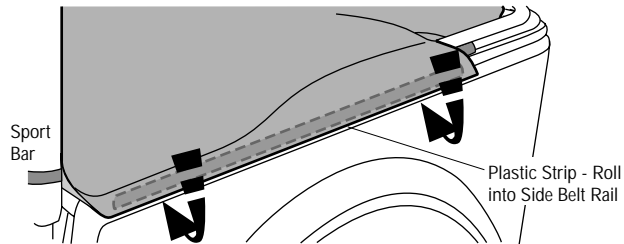

Step Seven

INSTALL PLASTIC STRIP INTO CORNER BELT RAILS

Roll the plastic strips sewn into the rear corners of the Duster into the Corner Belt Rails and into the retainer on the Tailgate Mounts. Slide the corner plastic strip toward the front of the vehicle and make sure that the plastic strip fits up into the Belt Rail so that the collar fits properly around the sport bar.

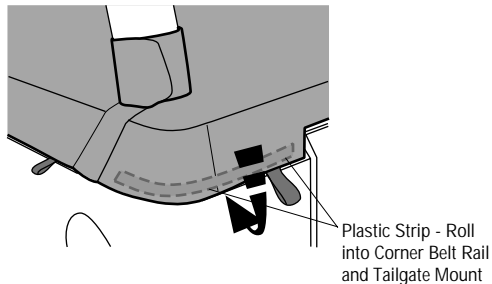

Note: The Plastic Protectors sewn into the fabric must be properly located to minimize abrasion between the Duster and the Soft Top Hardware.

Step Eight

FASTEN SPORT BAR COLLARS

Tuck the seat belt assemblies into the Sport Bar Collars and close the collars by wrapping the fabric around the sport bars and fastening the Hook and Loop strips to each other.

Tighten the buckle straps on the front of the Duster.

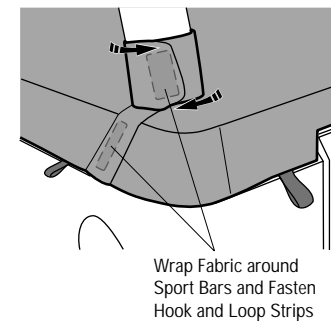

To Remove Duster

To remove the Duster, use the loops sewn to the fabric to release the plastic strips. Pull gently down, then straight out to release the plastic strip from the Belt Rails.

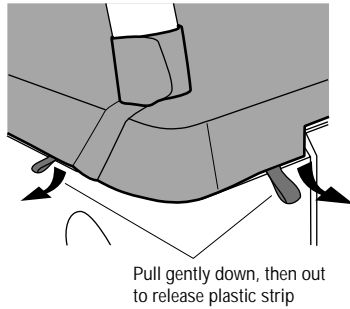

If You Have a New Windjammer on Your Vehicle

Step One

Locate the flap sewn to the rear of the Windjammer. Pull the flap out over the top of the front edge of the Duster.

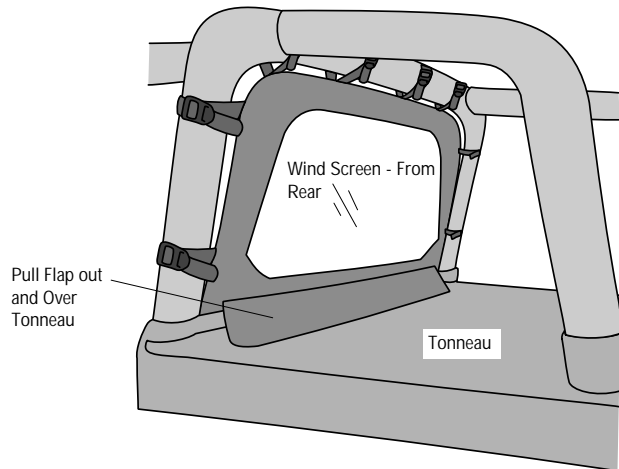

Step Two - Optional

Locate the Snap Head Screws in the parts kit supplied with the Windjammer.

Pull up on the front, reinforced edge of the Duster and mark the locations matching the three snaps on the Windjammer flap, on the webbing along the top of the Duster.

At the marked locations, push the sharp end of a Snap Head Screw through the Duster from the webbing side, to make a hole. Once a hole is formed, pull the screw back out of the hole. Then push the screw through the hole from the vinyl side so that the snap is on top of the vinyl. Thread an Acorn Locknut over the pointed end of the Snap Head Screw. Snap the Duster and the Windjammer together with the three snaps.

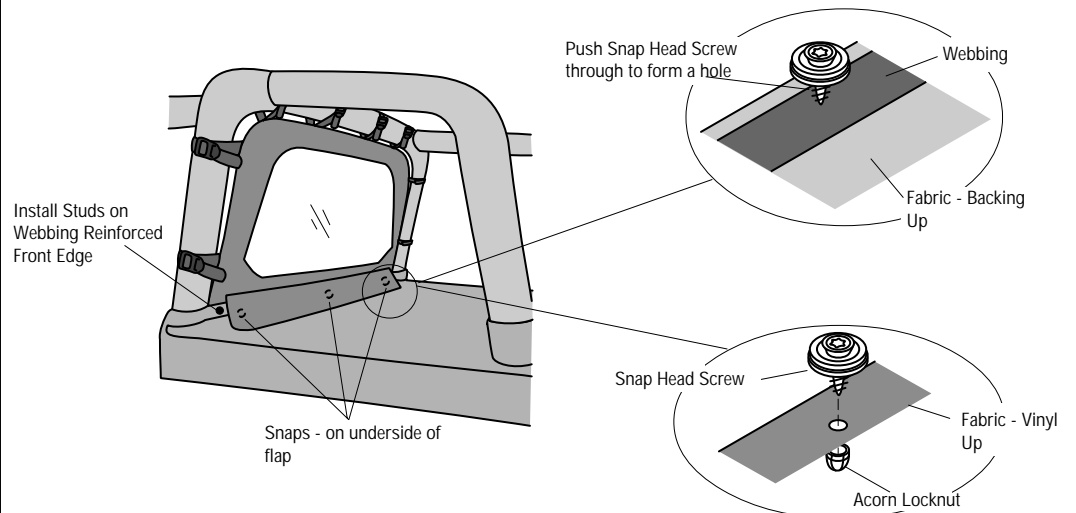

Care and Maintenance of your Duster

Your Duster is made of the finest materials available. To keep it looking new and for the maximum possible wear, it will need periodic cleaning and maintenance.

Washing: The fabric should be washed often using soap, warm water and a soft bristle brush. Rinse with clear water to remove all traces of soap.

Water: In the event of seeping through the seams, 3M Scotchgard® may be applied on the inside of the seams to stop the seepage. Rips in the fabric may be repaired with Bondex® iron on patches. Iron the patches to the Inside of the fabric, carefully following the Bondex® instructions.

Snaps: Keep snaps cleaned and lubricated with silicone sealant to help prevent snaps from sticking to the studs. If a snap does become stuck to a stud, use a screwdriver and GENTLY pry apart to prevent permanent damage to the snap or the fabric.

LIMITED WARRANTY

We warrant our product to be free from defects in material and workmanship, for the terms specified below, provided there has been normal use and proper maintenance. This warranty applies to the original purchaser only. All remedies under this warranty are limited to the repair or replacement of any item or items found by the factory to be defective within the time period specified.

If you have a warranty claim, first you must call our factory at the number below for instructions. You must retain proof of purchase and submit a copy with any items returned for warranty work. Upon completion of warranty work, if any, we will return the repaired or replaced item or items to you freight prepaid. Damage to our products caused by accidents, fire, vandalism, negligence, misinstallation, misuse, Acts of God, or by defective parts not manufactured by us, is not covered under this warranty.

THE WARRANTY TIME PERIOD IS AS FOLLOWS: ALL "SOFT GOODS" MANUFACTURED BY OUR COMPANY (USING PRIMARILY VINYL, PLASTICS, AND/OR FOAM): ONE YEAR FROM DATE OF PURCHASE.

ANY IMPLIED WARRANTIES OF MERCHANTABILITY AND/OR FITNESS FOR A PARTICULAR PURPOSE CREATED HEREBY ARE LIMITED IN DURATION TO THE SAME DURATION AND SCOPE AS THE EXPRESS WRITTEN WARRANTY. OUR COMPANY SHALL NOT BE LIABLE FOR ANY INCIDENTAL OR CONSEQUENTIAL DAMAGE.

Some states do not allow limitations on how long an implied warranty lasts, or the exclusion or limitation of incidental or consequential damages, so the above limitations or exclusions may not apply to you.

This warranty gives you specific legal rights, and you may also have other rights which vary from state to state.

For further information please contact:

Bestop Inc.
Customer Service
(800)845-3567

